

PLANNING COMMISSION AGENDA

CHAIRPERSON:

Brett Taylor



VICE CHAIRPERSON:

Liz Wynn

COMMISSIONERS: Brett Taylor, Liz Wynn, Chris Gomez, Marvin Hansen, Sarrah Peariso

MONDAY, MARCH 25, 2019; 7:00 P.M., COUNCIL CHAMBERS, 707 W. ACEQUIA, VISALIA CA

1. THE PLEDGE OF ALLEGIANCE –
2. CITIZEN'S COMMENTS – This is the time for citizens to comment on subject matters that are not on the agenda but are within the jurisdiction of the Visalia Planning Commission. The Commission requests that a 5-minute time limit be observed for comments. Please begin your comments by stating and spelling your name and city. Please note that issues raised under Citizen's Comments are informational only and the Commission will not take action at this time.
3. CHANGES OR COMMENTS TO THE AGENDA–
4. CONSENT CALENDAR - All items under the consent calendar are to be considered routine and will be enacted by one motion. For any discussion of an item on the consent calendar, it will be removed at the request of the Commission and made a part of the regular agenda.
 - Planning Division Fee Amendments: Consideration of revisions to the Planning Division fees as contained in City of Visalia Fee Resolution No. 2018-13.
5. PUBLIC HEARING – Andy Chamberlain
Conditional Use Permit No. 2019-04: A request by 4 Creeks Inc. to amend Conditional Use Permit No. 2011-26 to modify the Master Plan for the Gateway Business Park to allow a fast food restaurant with drive-thru on the southwest corner of Crowley Avenue and Ferne Street. The project site has a zoning designation of BRP (Business Research Park) and is located at 105 N. Ferne Street (APN: 081-170-024).The project is Categorical Exempt from the California Environmental Quality Act (CEQA) pursuant to CEQA Guidelines Section 15305, Categorical Exemption No. 2019-08.
6. PUBLIC HEARING – Cristobal Carrillo
Conditional Use Permit No. 2019-05: A request by Maegan La Roux to establish a tattooist shop in the C-MU (Mixed Use Commercial) zone. The site is located at 213 S. Oakhurst Avenue. (APN: 094-211-036) The project is Categorical Exempt from the California Environmental Quality Act (CEQA) pursuant to CEQA Guidelines Section 15301, Categorical Exemption No. 2019-14.
7. PUBLIC HEARING – Cristobal Carrillo
Conditional Use Permit No. 2019-06: A request by Gloria Villarreal to amend Conditional Use Permit No. 2012-01 to allow a 1,620 sq. ft. addition to the existing Glory Days assisted living facility in the R-1-5 (Single-Family Residential, 5,000 sq. ft. minimum site area) Zone. The site is located at 1303 S. Pinkham Street (APN 100-140-038). The project is Categorical Exempt from the California Environmental Quality Act (CEQA) pursuant to CEQA Guidelines Section 15301, Categorical Exemption No. 2019-12.

8. DIRECTOR'S REPORT/ PLANNING COMMISSION DISCUSSION-

- April 8, 2019 Planning Commission Meeting
- Housing Element TAC Meeting April 1, 2019
- GPA/COZ for Alex's Auto Body set for April 1, Council meeting

The Planning Commission meeting may end no later than 11:00 P.M. Any unfinished business may be continued to a future date and time to be determined by the Commission at this meeting. The Planning Commission routinely visits the project sites listed on the agenda.

For Hearing Impaired – Call (559) 713-4900 (TTY) 48-hours in advance of the scheduled meeting time to request signing services.

Any written materials relating to an item on this agenda submitted to the Planning Commission after distribution of the agenda packet are available for public inspection in the City Office, 315 E. Acequia Visalia, CA 93291, during normal business hours.

APPEAL PROCEDURE

THE LAST DAY TO FILE AN APPEAL IS THURSDAY, APRIL 4, 2019 BEFORE 5 PM

According to the City of Visalia Zoning Ordinance Section 17.02.145 and Subdivision Ordinance Section 16.04.040, an appeal to the City Council may be submitted within ten days following the date of a decision by the Planning Commission. An appeal form with applicable fees shall be filed with the City Clerk at 220 N. Santa Fe, Visalia, CA 93292. The appeal shall specify errors or abuses of discretion by the Planning Commission, or decisions not supported by the evidence in the record. The appeal form can be found on the city's website www.visalia.city or from the City Clerk.

THE NEXT REGULAR MEETING WILL BE HELD ON MONDAY, APRIL 8, 2019



REPORT TO CITY OF VISALIA PLANNING COMMISSION

HEARING DATE: March 25, 2019

PROJECT PLANNER: Cristobal Carrillo
Associate Planner, (559) 713-4443
E-mail: cristobal.carrillo@visalia.city

SUBJECT: Conditional Use Permit No. 2019-05: A request by Maegan La Roux to establish a tattooist shop in the C-MU (Mixed Use Commercial) zone. The site is located at 213 S. Oakhurst Avenue. (APN: 094-211-036)

STAFF RECOMMENDATION

Staff recommends approval of Conditional Use Permit No. 2019-05 based upon the findings and conditions in Resolution No. 2019-10. Staff's recommendation is based on the conclusion that the request is consistent with the General Plan and Zoning Ordinance.

RECOMMENDED MOTION

I move to approve Conditional Use Permit No. 2019-05 based on the findings and conditions in Resolution No. 2019-10.

PROJECT DESCRIPTION

Conditional Use Permit (CUP) No. 2019-05 is a request by Maegan La Roux to establish a tattooist studio within an existing 1,155 sq. ft. building as depicted in Exhibit "A". The project site contains three tenant suites, two located within the 1,155 sq. ft. building and a third within a detached 268 sq. ft. building. Per Exhibit "B", the tattooist studio will occupy the entire 1,155 sq. ft. main building, while the detached unit will continue to be occupied by a manicurist not affiliated with the tattoo use. Per Exhibit "B", the studio will contain one room for tattooing, with the remainder of the building used as a lobby, meeting area, break room, and office. The building would not be employed for residential purposes.

The Operational Statement (see Exhibit "C") states that only one employee will be on-site, working with a single client per day. Though the studio will keep regular business hours (Monday through Friday, 10:00am to 5:00pm), services will solely be provided by appointment. Per discussions with the Applicant, walk-in customers will not be permitted. In instances where no appointment has been made, the studio will not open for business.

BACKGROUND INFORMATION

General Plan Land Use Designation: Mixed Use Commercial

Zoning: C-MU (Mixed Use Commercial)

Surrounding Land Use and Zoning: North: C-MU / Single family residences

South: C-MU / Mixed commercial uses

East: C-MU / Single family residences

West: C-MU / Single and multi-family residences,
mixed commercial uses

Environmental Review:

Categorical Exemption No. 2019-14

Special Districts:

None.

Site Plan:

Site Plan Review No. 2019-001

RELATED PROJECTS

None.

PROJECT EVALUATION

Land Use Compatibility

The Visalia Municipal Code (VMC) identifies “tattooist” as a conditionally permitted use in the C-MU zone, requiring the approval of a CUP application. The surrounding area is zoned exclusively C-MU, containing predominantly service commercial uses. Existing residential uses to the north and east are unlikely to be impacted as the proposed tattoo studio will not create excessive noise and will operate with limited clientele and staff.

Parking

VMC Section 17.34.020.E.9 requires that barber shops/beauty salons and similar facilities provide two parking spaces per work station. The proposed tattooist studio and the existing manicure studio would each employ one person, resulting in the need for four onsite parking stalls. Per Exhibit “A” the project site currently contains four parking stalls, thus fulfilling the parking requirement for the existing and proposed uses.

Signage

During a site inspection conducted on March 13, 2019, staff discovered that a freestanding sign for the tattooist studio had been placed onsite (Figures 1 and 2 below). City records show that a sign permit has not been issued for the project site. Staff recommends that Condition No. 5 be adopted requiring issuance of a Building Permit for the sign within 60 days of approval of the CUP. Said signage will be required to comply with all requirements of the Visalia Municipal Code.

Figure 1



Figure 2



Environmental Review

The requested action is considered Categorical Exempt under Section 15301 of the Guidelines for the Implementation of the California Environmental Quality Act (CEQA). (Categorical Exemption No. 2019-14).

RECOMMENDED FINDINGS

1. That the proposed project will not be detrimental to the public health, safety, or welfare, or materially injurious to properties or improvements in the vicinity.
2. That the proposed conditional use permit is consistent with the policies and intent of the General Plan and Zoning Ordinance. Specifically, the project is consistent with the required finding of the Zoning Ordinance Section 17.38.110:
 - a. The proposed location of the conditional use permit is in accordance with the objectives of the Zoning Ordinance and the purposes of the zone in which the site is located.
 - b. The proposed location of the conditional use and the conditions under which it would be operated or maintained will not be detrimental to the public health, safety, or welfare, nor materially injurious to properties or improvements in the vicinity.
3. That the project is considered Categorical Exempt under Section 15301 of the Guidelines for the Implementation of the California Environmental Quality Act (CEQA). (Categorical Exemption No. 2019-14).

RECOMMENDED CONDITIONS OF APPROVAL

1. That the site shall be developed in substantial compliance with the comments and conditions of the Site Plan Review Committee as set forth under Site Plan Review No. 2019-001.
2. That the use be operated in substantial compliance with the site plan and floor plan shown in Exhibits "A" and "B".
3. That the use be operated in substantial compliance with the operational statement in Exhibit "C".
4. That substantial changes to the site plan, floor plan, or operational statement may require an amendment to this Conditional Use Permit as determined through the Site Plan Review process.
5. A Building Permit shall be obtained for the existing "The Painted Lady" freestanding sign within 60 days of approval of this Conditional Use Permit. Said signage shall comply with the requirements of Visalia Municipal Code Chapter 17.48 (Signs).
6. That all applicable federal, state and city laws, codes and ordinances be met.

APPEAL INFORMATION

According to the City of Visalia Zoning Ordinance Section 17.02.145, an appeal to the City Council may be submitted within ten days following the date of a decision by the Planning Commission. An appeal with applicable fees shall be in writing and shall be filed with the City Clerk at 220 N. Santa Fe Street, Visalia, CA 93291. The appeal shall specify errors or abuses of discretion by the Planning Commission, or decisions not supported by the evidence in the record. The appeal form can be found on the city's website www.ci.visalia.ca.us or from the city clerk.

Attachments:

- Related Plans & Policies
- Resolution No. 2109-10
- Exhibit "A" – Site Plan
- Exhibit "B" – Floor Plan
- Exhibit "C" – Operational Statement
- Categorical Exemption No. 2019-14
- Site Plan Review No. 2019-001 Comments
- General Plan Land Use Map
- Zoning Map
- Aerial Map
- Location Map

RELATED PLANS AND POLICIES

Conditional Use Permits

(Section 17.38)

17.38.010 Purposes and powers.

In certain zones conditional uses are permitted subject to the granting of a conditional use permit. Because of their unusual characteristics, conditional uses require special consideration so that they may be located properly with respect to the objectives of the zoning ordinance and with respect to their effects on surrounding properties. In order to achieve these purposes and thus give the zone use regulations the flexibility necessary to achieve the objectives of this title, the planning commission is empowered to grant or deny applications for conditional use permits and to impose reasonable conditions upon the granting of such permits. (Prior code § 7525)

17.38.020 Application procedures.

- A. Application for a conditional use permit shall be made to the planning commission on a form prescribed by the commission which shall include the following data:
1. Name and address of the applicant;
 2. Statement that the applicant is the owner of the property or is the authorized agent of the owner;
 3. Address and legal description of the property;
 4. The application shall be accompanied by such sketches or drawings as may be necessary by the planning division to clearly show the applicant's proposal;
 5. The purposes of the conditional use permit and the general description of the use proposed;
 6. Additional information as required by the historic preservation advisory committee.
- B. The application shall be accompanied by a fee set by resolution of the city council sufficient to cover the cost of handling the application. (Prior code § 7526)

17.38.030 Lapse of conditional use permit.

A conditional use permit shall lapse and shall become void twenty-four (24) months after the date on which it became effective, unless the conditions of the permit allowed a shorter or greater time limit, or unless prior to the expiration of twenty-four (24) months a building permit is issued by the city and construction is commenced and diligently pursued toward completion on the site which was the subject of the permit. A permit may be renewed for an additional period of one year; provided, that prior to the expiration of twenty-four (24) months from the date the permit originally became effective, an application for renewal is filed with the planning commission. The commission may grant or deny an application for renewal of a conditional use permit. In the case of a planned residential development, the recording of a final map and improvements thereto shall be deemed the same as a building permit in relation to this section. (Ord. 2001-13 § 4 (part), 2001: prior code § 7527)

17.38.040 Revocation.

Upon violation of any applicable provision of this title, or, if granted subject to a condition or conditions, upon failure to comply with the condition or conditions, a conditional use permit shall be suspended automatically. The planning commission shall hold a public hearing within sixty (60) days, in accordance with the procedure prescribed in Section 17.38.080, and if not satisfied that the regulation, general provision or condition is being complied with, may revoke the permit or take such action as may be necessary to insure compliance with the regulation, general provision or condition. Appeals of the decision of the planning commission may be made to the city council as provided in Section 17.38.120. (Prior code § 7528)

17.38.050 New application.

Following the denial of a conditional use permit application or the revocation of a conditional use permit, no application for a conditional use permit for the same or substantially the same conditional use on the same or substantially the same site shall be filed within one year from the date of denial or revocation of the permit unless such denial was a denial without prejudice by the planning commission or city council. (Prior code § 7530)

17.38.060 Conditional use permit to run with the land.

A conditional use permit granted pursuant to the provisions of this chapter shall run with the land and shall continue to be valid upon a change of ownership of the site or structure which was the subject of the permit application subject to the provisions of Section 17.38.065. (Prior code § 7531)

17.38.065 Abandonment of conditional use permit.

If the use for which a conditional use permit was approved is discontinued for a period of one hundred eighty (180) days, the use shall be considered abandoned and any future use of the site as a conditional use will require the approval of a new conditional use permit.

17.38.070 Temporary uses or structures.

- A. Conditional use permits for temporary uses or structures may be processed as administrative matters by the city planner and/or planning division staff. However, the city planner may, at his/her discretion, refer such application to the planning commission for consideration.
- B. The city planner and/or planning division staff is authorized to review applications and to issue such temporary permits, subject to the following conditions:
 1. Conditional use permits granted pursuant to this section shall be for a fixed period not to exceed thirty (30) days for each temporary use not occupying a structure, including promotional enterprises, or six months for all other uses or structures.
 2. Ingress and egress shall be limited to that designated by the planning division. Appropriate directional signing, barricades, fences or landscaping shall be provided where required. A security officer may be required for promotional events.
 3. Off-street parking facilities shall be provided on the site of each temporary use as prescribed in Section 17.34.020.
 4. Upon termination of the temporary permit, or abandonment of the site, the applicant shall remove all materials and equipment and restore the premises to their original condition.
 5. Opening and closing times for promotional enterprises shall coincide with the hours of operation of the sponsoring commercial establishment. Reasonable time limits for other uses may be set by the city planner and planning division staff.
 6. Applicants for a temporary conditional use permit shall have all applicable licenses and permits prior to issuance of a conditional use permit.
 7. Signing for temporary uses shall be subject to the approval of the city planner.
 8. Notwithstanding underlying zoning, temporary conditional use permits may be granted for fruit and vegetable stands on properties primarily within undeveloped agricultural areas. In reviewing applications for such stands, issues of traffic safety and land use compatibility shall be evaluated and mitigation measures and conditions may be imposed to ensure that the stands are built and are operated consistent with appropriate construction standards, vehicular access and off-street parking. All fruits and vegetables sold at such stands shall be grown by the owner/operator or purchased by said party directly from a grower/farmer.
- C. The applicant may appeal an administrative decision to the planning commission. (Ord. 9605 § 30 (part), 1996: prior code § 7532)

17.38.080 Public hearing--Notice.

- A. The planning commission shall hold at least one public hearing on each application for a conditional use permit.
- B. Notice of the public hearing shall be given not less than ten days nor more than thirty (30) days prior to the date of the hearing by mailing a notice of the time and place of the hearing to property owners within three hundred (300) feet of the boundaries of the area occupied or to be occupied by the use which is the subject of the hearing, and by publication in a newspaper of general circulation within the city. (Prior code § 7533)

17.38.090 Investigation and report.

The planning staff shall make an investigation of the application and shall prepare a report thereon which shall be submitted to the planning commission. (Prior code § 7534)

17.38.100 Public hearing--Procedure.

At the public hearing the planning commission shall review the application and the statement and drawing submitted therewith and shall receive pertinent evidence concerning the proposed use and the proposed conditions under which it would be operated or maintained, particularly with respect to the findings prescribed in Section 17.38.110. The planning commission may continue a public hearing from time to time as it deems necessary. (Prior code § 7535)

17.38.110 Action by planning commission.

- A. The planning commission may grant an application for a conditional use permit as requested or in modified form, if, on the basis of the application and the evidence submitted, the commission makes the following findings:
 - 1. That the proposed location of the conditional use is in accordance with the objectives of the zoning ordinance and the purposes of the zone in which the site is located;
 - 2. That the proposed location of the conditional use and the conditions under which it would be operated or maintained will not be detrimental to the public health, safety or welfare, or materially injurious to properties or improvements in the vicinity.
- B. A conditional use permit may be revocable, may be granted for a limited time period, or may be granted subject to such conditions as the commission may prescribe. The commission may grant conditional approval for a permit subject to the effective date of a change of zone or other ordinance amendment.
- C. The commission may deny an application for a conditional use permit. (Prior code § 7536)\

17.38.120 Appeal to city council.

The decision of the City planning commission on a conditional use permit shall be subject to the appeal provisions of Section 17.02.145. (Prior code § 7537) (Ord. 2006-18 § 6, 2007)

17.38.130 Effective date of conditional use permit.

A conditional use permit shall become effective immediately when granted or affirmed by the council, or upon the sixth working day following the granting of the conditional use permit by the planning commission if no appeal has been filed. (Prior code § 7539)

RESOLUTION NO. 2019-10

A RESOLUTION OF THE PLANNING COMMISSION OF THE CITY OF VISALIA APPROVING CONDITIONAL USE PERMIT NO. 2019-05, A REQUEST BY MAEGAN LA ROUX TO ESTABLISH A TATTOOIST STUDIO IN THE C-MU (MIXED USE COMMERCIAL) ZONE. THE SUBJECT SITE IS LOCATED AT 213 S. OAKHURST AVENUE (APN: 094-211-036).

WHEREAS, Conditional Use Permit No. 2019-10, is a request by Maegan La Roux to establish a tattooist studio in the C-MU (Mixed Use Commercial) Zone. The subject site is located at 213 S. Oakhurst Avenue (APN: 094-211-036); and

WHEREAS, the Planning Commission of the City of Visalia, after duly published notice did hold a public hearing before said Commission on March 25, 2019; and

WHEREAS, the Planning Commission of the City of Visalia finds the Conditional Use Permit to be in accordance with Chapter 17.38.110 of the Zoning Ordinance of the City of Visalia based on the evidence contained in the staff report and testimony presented at the public hearing; and

WHEREAS, the Planning Commission finds the project to be Categorically Exempt consistent with the California Environmental Quality Act (CEQA) and City of Visalia Environmental Guidelines.

NOW, THEREFORE, BE IT RESOLVED that the project is exempt from further environmental review pursuant to CEQA Section 15301.

NOW, THEREFORE, BE IT FURTHER RESOLVED that the Planning Commission of the City of Visalia makes the following specific findings based on the evidence presented:

1. That the proposed project, as conditioned, will not be detrimental to the public health, safety, or welfare, or materially injurious to properties or improvements in the vicinity.
2. That the proposed conditional use permit is consistent with the policies and intent of the General Plan and Zoning Ordinance. Specifically, the project is consistent with the required findings of Zoning Ordinance Section 17.38.110:
 - a. The proposed location of the conditional use permit is in accordance with the objectives of the Zoning Ordinance and the purposes of the zone in which the site is located.
 - b. The proposed location of the conditional use and the conditions under which it would be operated or maintained will not be detrimental to the public health, safety, or welfare, nor materially injurious to properties or improvements in the vicinity.
3. That the project is considered Categorically Exempt under Section 15301 of the Guidelines for the Implementation of CEQA. (Categorical Exemption No. 2019-14).

BE IT FURTHER RESOLVED that the Planning Commission hereby approves the Conditional Use Permit on the real property here described in accordance with the terms of this resolution under the provisions of Section 17.38.110 of the Ordinance Code of the City of Visalia, subject to the following conditions:

1. That the site shall be developed in substantial compliance with the comments and conditions of the Site Plan Review Committee as set forth under Site Plan Review No. 2019-001.
2. That the use be operated in substantial compliance with the site plan and floor plan shown in Exhibits "A" and "B".
3. That the use be operated in substantial compliance with the operational statement in Exhibit "C".
4. That substantial changes to the site plan, floor plan, or operational statement may require an amendment to this Conditional Use Permit as determined through the Site Plan Review process.
5. A Building Permit shall be obtained for the existing "The Painted Lady" freestanding sign within 60 days of approval of this Conditional Use Permit. Said signage shall comply with the requirements of Visalia Municipal Code Chapter 17.48 (Signs).
6. That all applicable federal, state and city laws, codes and ordinances be met.

Exhibit "A"

PROPERTY OWNER: PHUUN CAREN
 213 S. OAKHURST SUTED
 APPLICANT: MAEGAN LA ROUX
 1016 E. KANEATH AVE, U.S. 50414
 769 0324884
 UTILITIES: CAP WATER
 SOCIAL EDISON
 SOCIAL GAS
 CITY WISCONSIN SEWER
 APN's: 094211-036
 GROSS ACRES: 5327 SQFT
 FLOOD ZONE: XL

FEB 5, 2019
 THE PAINTED LADY
 213 S OAKHURST ST
 EXTERIOR SITE PLAN

MINERAL KING

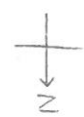
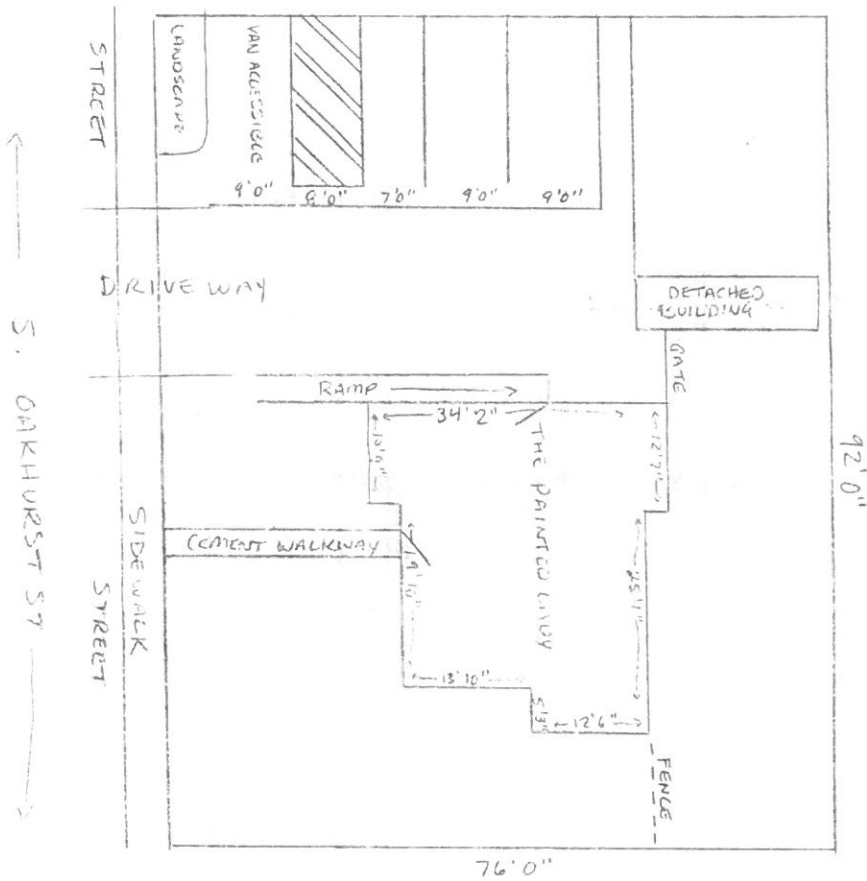

Exhibit "B"

MEGAN LA ROUX
264-832-4884

FEB 5, 2019
THE PAINTERLADY
213 S. OAKHURST ST 1155 SQ FT
INTERIOR SITE PLAN

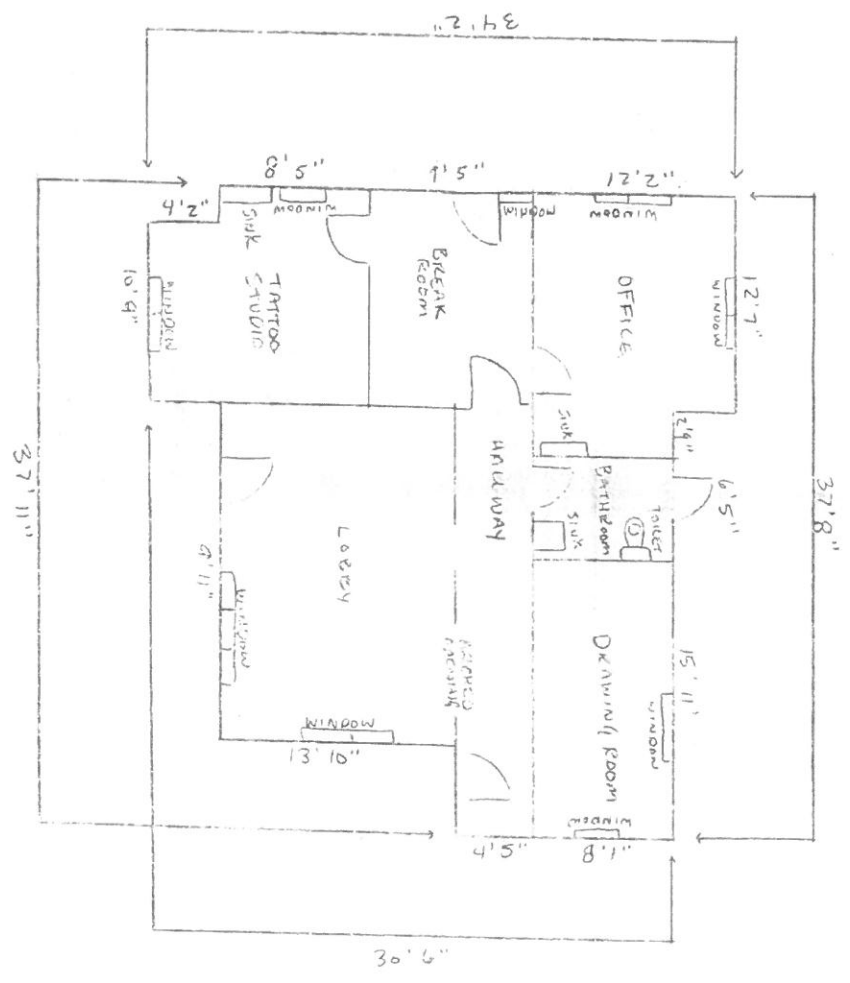

Exhibit "C"

1/2/2019

The Painted Lady Business Description

The Painted Lady is an upscale, by appointment only private tattoo studio consisting of only one artist, Mae La Roux, taking on one client per day. Operating hours are 10am to 5pm Monday through Friday. The Painted Lady values a quiet and peaceful working environment and does not attract foot traffic as their clientele is mostly non-local and travels from all over the country and world.

Maegan La Roux

NOTICE OF EXEMPTION

City of Visalia
315 E. Acequia Ave.
Visalia, CA 93291

To: County Clerk
County of Tulare
County Civic Center
Visalia, CA 93291-4593

Conditional Use Permit No. 2019-05

PROJECT TITLE

213 S. Oakhurst Avenue

PROJECT LOCATION

Visalia

PROJECT LOCATION - CITY

Tulare

COUNTY

A request by Maegan La Roux to allow a tattooist within an existing building in the C-MU (Mixed Use Commercial) zone.

DESCRIPTION - Nature, Purpose, & Beneficiaries of Project

City of Visalia, 315 E. Acequia Avenue, Visalia CA 93291, (559) 713-4443,
Email: Cristobal.Carrillo@visalia.city

NAME OF PUBLIC AGENCY APPROVING PROJECT

Maegan La Roux, 1016 E. Kaweah Avenue, Visalia CA 93292, missmaetattoo@gmail.com

NAME AND ADDRESS OF APPLICANT CARRYING OUT PROJECT

Maegan La Roux, 1016 E. Kaweah Avenue, Visalia CA 93292, missmaetattoo@gmail.com

NAME AND ADDRESS OF AGENT CARRYING OUT PROJECT

EXEMPT STATUS: (Check one)

- Ministerial - Section 15073
- Emergency Project - Section 15071
- Categorical Exemption - State type and Section number: **Section 15301**
- Statutory Exemptions- State code number:

A request to establish a tattooist shop within an existing building.

REASON FOR PROJECT EXEMPTION

Cristobal Carrillo, Associate Planner

CONTACT PERSON

(559) 713-4443

AREA CODE/PHONE

DATE

**Paul Scheibel, AICP
ENVIRONMENTAL COORDINATOR**



#3

MEETING DATE: January 9, 2019

SITE PLAN NO. 19-001

PARCEL MAP NO.

SUBDIVISION:

LOT LINE ADJUSTMENT NO.

Enclosed for your review are the comments and decisions of the Site Plan Review committee. Please review all comments since they may impact your project.

RESUBMIT Major changes to your plans are required. Prior to accepting construction drawings for building permit, your project must return to the Site Plan Review Committee for review of the revised plans.

During site plan design/policy concerns were identified, schedule a meeting with
 Planning Engineering prior to resubmittal plans for Site Plan Review.

Solid Waste Parks and Recreation Fire Dept.

REVISE AND PROCEED (see below)

A revised plan addressing the Committee comments and revisions must be submitted for Off-Agenda Review and approval prior to submitting for building permits or discretionary actions.

Submit plans for a building permit between the hours of 9:00 a.m. and 4:00 p.m., Monday through Friday.

Your plans must be reviewed by:

CITY COUNCIL

REDEVELOPMENT

PLANNING COMMISSION

PARK/RECREATION

CVP

HISTORIC PRESERVATION

OTHER: _____

ADDITIONAL COMMENTS :

If you have any questions or comments, please call Jason Huckleberry at (559) 713-4259.

Site Plan Review Committee



**BUILDING/DEVELOPMENT PLAN
REQUIREMENTS
ENGINEERING DIVISION**

- Jason Huckleberry 713-4259
- Adrian Rubalcaba 713-4271
- Diego Corvera 713-4209

ITEM NO: 3 DATE: JANUARY 9, 2019

SITE PLAN NO.: 19-001
 PROJECT TITLE: THE PAINTED LADY
 DESCRIPTION: BY APPOINTMENT ONLY TATTOO
 APPLICANT: MAEGAN LA ROUX
 PROP OWNER: DAVID GONZALEZ
 LOCATION: 213 S OAKHURST ST
 APN: 094-211-036

SITE PLAN REVIEW COMMENTS

- REQUIREMENTS (indicated by checked boxes)
- Install curb return with ramp, with _____ radius;
- Install curb; gutter
- Drive approach size: Use radius return;
- Sidewalk: _____ width; parkway width at _____
- Repair and/or replace any sidewalk across the public street frontage(s) of the subject site that has become uneven, cracked or damaged and may constitute a tripping hazard.
- Replace any curb and gutter across the public street frontage(s) of the subject site that has become uneven and has created areas where water can stand.
- Right-of-way dedication required. A title report is required for verification of ownership.
- Deed required prior to issuing building permit;
- City Encroachment Permit Required.
 Insurance certificate with general & auto liability (\$1 million each) and workers compensation (\$1 million), valid business license, and appropriate contractor's license must be on file with the City, and valid Underground Service Alert # provided prior to issuing the permit. Contact Encroachment Tech. at 713-4414.
- CalTrans Encroachment Permit required. CalTrans comments required prior to issuing building permit. Contacts: David Deel (Planning) 488-4088;
- Landscape & Lighting District/Home Owners Association required prior to approval of Final Map. Landscape & Lighting District will maintain common area landscaping, street lights, street trees and local streets as applicable. Submit completed Landscape and Lighting District application and filing fee a min. of 75 days before approval of Final Map.
- Landscape & irrigation improvement plans to be submitted for each phase. Landscape plans will need to comply with the City's street tree ordinance. The locations of street trees near intersections will need to comply with Plate SD-1 of the City improvement standards. A street tree and landscape master plan for all phases of the subdivision will need to be submitted with the initial phase to assist City staff in the formation of the landscape and lighting assessment district.
- Grading & Drainage plan required. If the project is phased, then a master plan is required for the entire project area that shall include pipe network sizing and grades and street grades. Prepared by registered civil engineer or project architect. All elevations shall be based on the City's benchmark network. Storm run-off from the project shall be handled as follows: a) directed to the City's existing storm drainage system; b) directed to a permanent on-site basin; or c) directed to a temporary on-site basin is required until a connection with adequate capacity is available to the City's storm drainage system. On-site basin: _____ : _____ maximum side slopes, perimeter fencing required, provide access ramp to bottom for maintenance.
- Grading permit is required for clearing and earthwork performed prior to issuance of the building permit.
- Show finish elevations. (Minimum slopes: A.C. pavement = 1%, Concrete pavement = 0.25%. Curb & Gutter = .020%, V-gutter = 0.25%)
- Show adjacent property grade elevations. A retaining wall will be required for grade differences greater than 0.5 feet at the property line.
- All public streets within the project limits and across the project frontage shall be improved to their full width, subject to available right of way, in accordance with City policies, standards and specifications.
- Traffic indexes per city standards:

- Install street striping as required by the City Engineer.
- Install landscape curbing (typical at parking lot planters).
- Minimum paving section for parking: 2" asphalt concrete paving over 4" Class 2 Agg. Base, or 4" concrete pavement over 2" sand.
- Design Paving section to traffic index of 5.0 min. for solid waste truck travel path.
- Provide "R" value tests: each at
- Written comments required from ditch company Contacts: James Silva 747-1177 for Modoc, Persian, Watson, Oakes, Flemming, Evans Ditch and Peoples Ditch; Jerry Hill 686-3425 for Tulare Irrigation Canal, Packwood and Cameron Creeks; Bruce George 747-5601 for Mill Creek and St. John's River.
- Access required on ditch bank, 15' minimum Provide wide riparian dedication from top of bank.
- Show Valley Oak trees with drip lines and adjacent grade elevations. Protect Valley Oak trees during construction in accordance with City requirements.
- A permit is required to remove Valley Oak trees. Contact Public Works Admin at 713-4428 for a Valley Oak tree evaluation or permit to remove. A pre-construction conference is required.
- Relocate existing utility poles and/or facilities.
- Underground all existing overhead utilities within the project limits. Existing overhead electrical lines over 50kV shall be exempt from undergrounding.
- Subject to existing Reimbursement Agreement to reimburse prior developer:
- Fugitive dust will be controlled in accordance with the applicable rules of San Joaquin Valley Air District's Regulation VIII. Copies of any required permits will be provided to the City.
- If the project requires discretionary approval from the City, it may be subject to the San Joaquin Valley Air District's Rule 9510 Indirect Source Review per the rule's applicability criteria. A copy of the approved AIA application will be provided to the City.
- If the project meets the one acre of disturbance criteria of the State's Storm Water Program, then coverage under General Permit Order 2009-0009-DWQ is required and a Storm Water Pollution Prevention Plan (SWPPP) is needed. A copy of the approved permit and the SWPPP will be provided to the City.
- Comply with prior comments. Resubmit with additional information. Redesign required.

Additional Comments:

- 1. Prior building use will apply as credit, no impact fees will be assessed with this project.**
- 2. Engineering has no comments.**

SUMMARY OF APPLICABLE DEVELOPMENT IMPACT FEES

Site Plan No: 19-001
Date: 01/09/2019

Summary of applicable Development Impact Fees to be collected at the time of building permit:
(Preliminary estimate only! Final fees will be based on the development fee schedule in effect at the time of building permit issuance.)

(Fee Schedule Date:08/03/2018)
(Project type for fee rates:COMMERCIAL)

Existing uses may qualify for credits on Development Impact Fees. **COMMERCIAL**

FEE ITEM	FEE RATE
<input type="checkbox"/> Groundwater Overdraft Mitigation Fee	
<input type="checkbox"/> Transportation Impact Fee	
<input type="checkbox"/> Trunk Line Capacity Fee	
<input type="checkbox"/> Sewer Front Foot Fee	
<input type="checkbox"/> Storm Drain Acq/Dev Fee	
<input type="checkbox"/> Park Acq/Dev Fee	
<input type="checkbox"/> Northeast Specific Plan Fees	
<input type="checkbox"/> Waterways Acquisition Fee	
<input type="checkbox"/> Public Safety Impact Fee: Police	
<input type="checkbox"/> Public Safety Impact Fee: Fire	
<input type="checkbox"/> Public Facility Impact Fee	
<input type="checkbox"/> Parking In-Lieu	

Reimbursement:

- 1.) No reimbursement shall be made except as provided in a written reimbursement agreement between the City and the developer entered into prior to commencement of construction of the subject facilities.
- 2.) Reimbursement is available for the development of arterial/collector streets as shown in the City's Circulation Element and funded in the City's transportation impact fee program. The developer will be reimbursed for construction costs and right of way dedications as outlined in Municipal Code Section 16.44. Reimbursement unit costs will be subject to those unit costs utilized as the basis for the transportation impact fee.
- 3.) Reimbursement is available for the construction of storm drain trunk lines and sanitary sewer trunk lines shown in the City's Storm Water Master Plan and Sanitary Sewer System Master Plan. The developer will be reimbursed for construction costs associated with the installation of these trunk lines.



Diego Corvera

SITE PLAN REVIEW COMMENTS

Andrew Chamberlain 559-713-4003

Date: January 9, 2019

SITE PLAN NO: 2019-01
PROJECT TITLE: Painted Lady Tattoo
DESCRIPTION: Tattoo (C-MU)
APPLICANT: Maegan La Roux
PROP. OWNER: David G
LOCATION TITLE: 213 S Oakhurst
APN TITLE: 094-211-036
GENERAL PLAN: Commercial Mixed Use
ZONING: C-MU – Commercial Mixed Use

Rule 9510 – This project is not subject to the Rule 9510 requirements of the San Joaquin Valley Air Pollution Control District – see District web-site for information.

Planning Division Recommendation:

- Revise and Proceed –CUP for Tattoo in CMU zone
 Resubmit

Project Requirements

- Conditional Use Permit required for Tattoo in the C-MU zone
- Additional Information as Needed

PROJECT SPECIFIC INFORMATION:

1. Conditional Use Permit required for Tattoo in the C-MU zone.
2. The operational statement indicates only one tattoo chair/work station for one operator at this location.
3. Provide a detailed operational statement with the CUP application.
4. Minimum parking for these types of usages is four parking stalls which are present on the site
5. Any type of residential use or over-night sleeping facilities requires a conditional use permit.
6. Meet all other city codes and ordinances.

17.19.060 Development standards in the C-MU zones outside the downtown area

The following development standards shall apply to property located in the C-MU zone and located outside the Downtown Area, which is defined as the area that is south of Murray Avenue, west of Ben Maddox Way, north of Mineral King Avenue, and east of Conyer Street:

- A. Minimum site area: five (5) acres.
- B. Maximum building height: fifty (50) feet.
- C. Minimum required yards (building setbacks):
 1. Front: fifteen (15) feet;
 2. Rear: zero (0) feet;
 3. Rear yards abutting an R-1 or R-M zone district: fifteen (15) feet;
 4. Side: zero (0) feet;
 5. Side yards abutting an R-1 or R-M zone district: fifteen (15) feet;
 6. Street side yard on corner lot: ten (10) feet.
- D. Minimum required landscaped yard (setback) areas:
 1. Front: fifteen (15) feet;
 2. Rear: five (5) feet;
 3. Rear yards abutting an R-1 or R-M zone district: five (5) feet;
 4. Side: five (5) feet (except where a building is located on side property line);

5. Side yards abutting an R-1 or R-M zone district: five (5) feet;
6. Street side on corner lot: ten (10) feet.
7. The provisions of Chapter 17.58 shall also be met, if applicable.

Parking: Vehicle Storage Lot – required parking is determined by the layout of the final plan to determine if any “Required” parking is needed.

Landscaping:

1. The City has adopted the State Water Efficient Landscape Ordinance.
2. Maintenance of landscaped areas. - A landscaped area provided in compliance with the regulations prescribed in this title or as a condition of a use permit or variance shall be planted with materials suitable for screening or ornamenting the site, whichever is appropriate, and plant materials shall be maintained and replaced as needed, to screen or ornament the site. (Prior code § 7484)

Lighting:

1. All lighting is to be designed and installed so as to prevent any significant direct or indirect light or glare from falling upon any adjacent residential property. This will need to be demonstrated in the building plans and prior to final on the site.

NOTE: Staff recommendations contained in this document are not to be considered support for a particular action or project unless otherwise stated in the comments. The comments found on this document pertain to the site plan submitted for review on the above referenced date. Any changes made to the plan submitted must be submitted for additional review.

Signature _____ 

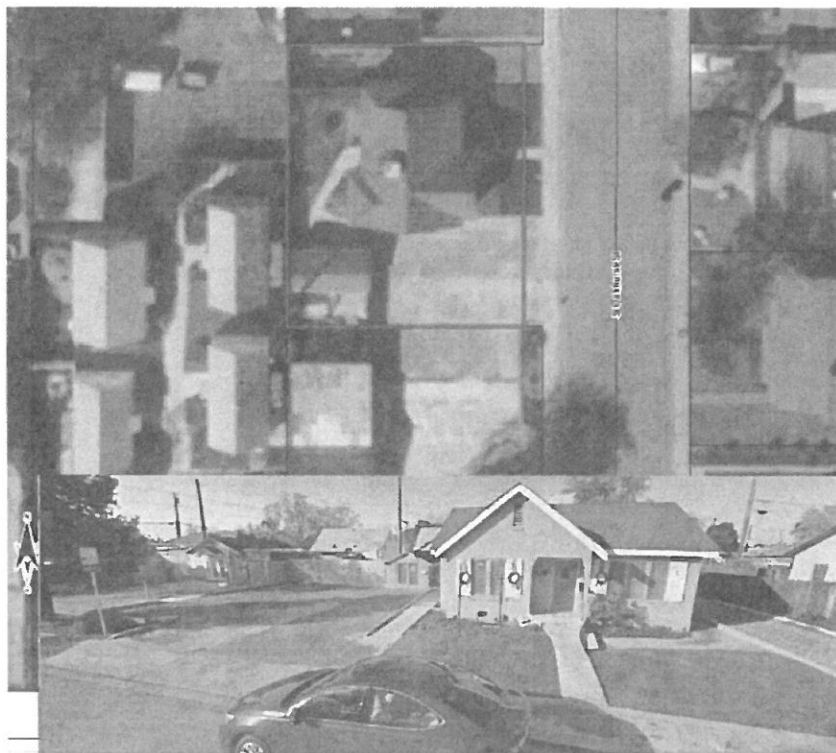

SITE PLAN # 2019-01

SFR 19001
THE PAINTED LADY
213 S OAKHURST ST.

City of Visalia
Building: Site Plan
Review Comments

NOTE: These are general comments and DO NOT constitute a complete plan check for your specific project
Please refer to the applicable California Code & local ordinance for additional requirements.

- A building permit will be required. *For information call (559) 713-4444*
- Submit 1 digital set of professionally prepared plans and 1 set of calculations. (Small Tenant Improvements)
- Submit 1 digital set of plans prepared by an architect or engineer. Must comply with 2016 California Building Cod Sec. 2308 for conventional light-frame construction or submit 1 digital set of engineered calculations.
- Indicate abandoned wells, septic systems and excavations on construction plans.
- You are responsible to ensure compliance with the following checked items:**
- Meet State and Federal requirements for accessibility for persons with disabilities.
- A path of travel, parking and common area must comply with requirements for access for persons with disabilities.
- All accessible units required to be adaptable for persons with disabilities.
- Maintain sound transmission control between units minimum of 50 STC.
- Maintain fire-resistive requirements at property lines.
- A demolition permit & deposit is required. *For information call (559) 713-4444*
- Obtain required permits from San Joaquin Valley Air Pollution Board. *For information call (661) 392-5500*
- Plans must be approved by the Tulare County Health Department. *For information call (559) 624-8011*
- Project is located in flood zone _____ • Hazardous materials report.
- Arrange for an on-site inspection. (Fee for inspection \$157.00) *For information call (559) 713-4444*
- School Development fees. Commercial \$0.61 per square foot. Residential \$3.79 per square foot.
- Park Development fee \$ _____, per unit collected with building permits.
- Existing address must be changed to be consistent with city address. *For information call (559) 713-4320*
- Acceptable as submitted
- No comments at this time

Additional comments: _____

VAL GARCIA 1/9/19
Signature



Site Plan Review Comments For:
Visalia Fire Department
Danny Wristen, Interim Fire Marshal
420 N. Burke
Visalia, CA 93292
559-713-4056 Office
559-713-4808 Fax

Date: 01/09/2019
Item # 3
Site Plan # 19001 RESUBMITTAL
Project: THE PAINTED LADY
Description: BY APPOINTMENT ONLY TATTOO
Applicant: MAEGHAN LA ROUX
Location: 213 S. OAKHURST
APN: 094-211-036

The following comments are applicable when checked:

- The Site Plan Review comments are issued as general overview of your project. With further details, additional requirements will be enforced at the Plan Review stage. Please refer to the 2016 California Fire Code (CFC), 2016 California Building Codes (CBC) and City of Visalia Municipal Codes.
- All fire detection, alarm, and extinguishing systems in existing buildings shall be maintained in an operative condition at all times and shall be replaced or repaired where defective. If building has been vacant for a significant amount of time, the fire detection, alarm, and or extinguishing systems may need to be evaluated by a licensed professional. *2016 CFC 901.6*
- No fire protection items required for parcel map or lot line adjustment; however, any future projects will be subject to fire & life safety requirements including fire protection.
- Construction and demolition sites prior to and during construction shall comply with the following:
 - Water Supply for fire protection, either temporary or permanent, shall be made available as soon as combustible materials arrive on the site. *2016 CFC 3312*
 - An all-weather, 20 feet width Construction Access Road capable of holding a 75,000 pound fire apparatus. Fire apparatus access shall be provided within 100 feet of temporary or permanent fire department connections. *2016 CFC 3310*
- More information is needed before a Site Plan Review can be conducted. Please submit plans with more detail. Please include information on

General:

- Address numbers must be placed on the exterior of the building in such a position as to be clearly and plainly visible from the street. Numbers will be at least four inches (4") high and shall be of a color to contrast with their background. If multiple addresses served are by a common driveway, the range of numbers shall be posted at the roadway/driveway. *2016 CFC 505.1*
- All hardware on exit doors, illuminated exit signs and emergency lighting shall comply with the 2016 California Fire Code. This includes all locks, latches, bolt locks, panic hardware, fire exit hardware and gates.
- Commercial dumpsters with 1.5 cubic yards or more shall not be stored or placed within 5 feet of combustible walls, openings, or a combustible roof eave line except when protected by a fire sprinkler system. *2016 CFC 304.3.3*

- A Knox Box key lock system is required. Where access to or within a structure or area is restricted because of secured openings (doors and/or gates), a key box is to be installed in an approved location. The key box shall be ordered using an approved Knox Authorization Order Form. The forms are located at the fire department administration office located at 420 N Burke, Visalia, CA 93292. Please allow adequate time for shipping and installation. *2016 CFC 506.1*
- If your business handles hazardous material in amounts that exceed the Maximum Allowable Quantities listed on *Table 5003.1.1(1), 5003.1.1(2), 5003.1.1(3) and 5003.1.1(4) of the 2016 California Fire Code*, you are required to submit an emergency response plan to the Tulare County Health Department. Also you shall indicate the quantities on your building plans and prior to the building final inspection a copy of your emergency response plan and Safety Data Sheets shall be submitted to the Visalia Fire Department.

Water Supply for Residential, Commercial & Industrial:

Residential

- Fire hydrant spacing and location shall comply with the following requirements:
The exact location and number of fire hydrants shall be at the discretion of the fire marshal, fire chief and/or their designee. *Visalia Municipal Code 16.36.120(5)*
 - Single-family residential developments shall be provided with fire hydrants every six hundred (600) lineal feet of residential frontage. In isolated developments, no less than two (2) fire hydrants shall be provided.
 - Multi-family, zero lot line clearance, mobile home park or condominium developments shall be provided with fire hydrants every four hundred (400) lineal feet of frontage. In isolated developments, no less than two (2) fire hydrants shall be provided.
 - Multi-family or condominium developments with one hundred (100) percent coverage fire sprinkler systems shall be provided with fire hydrants every six (600) lineal feet of frontage. In isolated developments, no less than two (2) fire hydrants shall be provided.

Commercial & Industrial

- Where a portion of the facility or building is more than 400 feet from a hydrant on a fire apparatus access road, on-site fire hydrant(s) shall be provided. *2016 CFC 507.5.1*
- Due to insufficient building information, the number and distance between fire hydrants cannot be determined by the Site Plan Review process. The number of fire hydrants and distance between required fire hydrants shall be determined by utilizing type of construction and square footage in accordance with *CFC 2016 Appendix C102 & C103 & CFC 507.5.1*
- To determine fire hydrant location(s) and distribution the following information was provided to the Site Plan Review committee: **Type of construction** _____ **Square footage** _____

Emergency Access

- A fire apparatus access roads shall be provided and must comply with the 2016 CFC and extend within 150 of all portions of the facility and all portions of the exterior walls of the first story of the building as measured by an approved route around the exterior of the building or facility. Fire apparatus access

roads shall have an unobstructed width of not less than 20 feet. Minimum turning radius for emergency fire apparatus shall be 20 feet inside radius and 43 feet outside radius. *2016 CFC 503.1.1*

☐ Buildings or portions of buildings or facilities with a vertical distance between the grade plan and the highest roof surface that exceed 30 feet shall provide an approved fire apparatus access roads capable of accommodating fire department aerial apparatus.

- Access roads shall have a minimum unobstructed width of 26 feet, exclusive of shoulders.
- Access routes shall be located within a minimum of 15 feet and maximum of 30 feet from the building, and shall be positioned parallel to one entire side of the building.
- Overhead utility and power lines shall not be located over the aerial fire apparatus access road or between the aerial fire apparatus road and the building.

☐ Fire apparatus access roads in excess of 150 feet and dead end shall be provided with a turnaround. Fire apparatus access roads with a length of 151-500 feet shall be a minimum of 20 feet in width. Length of 501-750 feet shall be 26 feet in width. *2016 CFC Table D103.4*

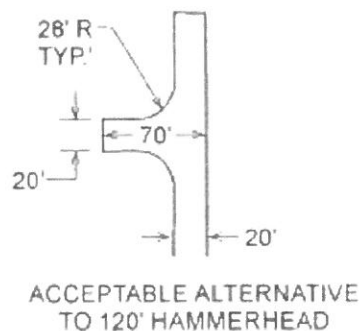
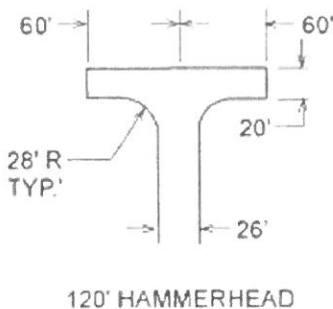
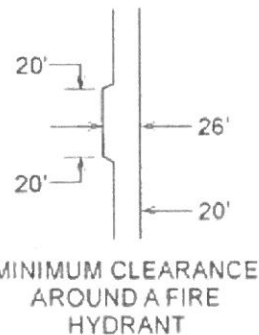
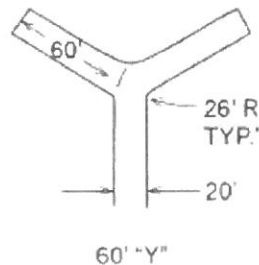
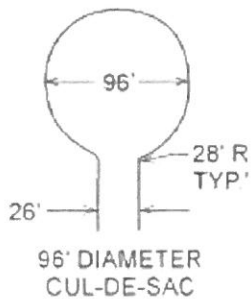

☐ Approved No PARKING – FIRE LANE signs shall be provided for fire apparatus access roads to identify such roads or prohibit the obstruction thereof. Signs shall have a minimum dimension of 12 inches wide by 18 inches high and have red letters on a white reflective background. *2013 CFC 503.3/D103.6*

SIGN TYPE "A"



SIGN TYPE "C"



SIGN TYPE "D"



- On site Fire Apparatus Access Roads shall be provided and have an unobstructed width of not less than the following:
 - 20 feet width, exclusive of shoulders (No Parking)
 - More than 26 feet width, exclusive of shoulders (No Parking one side)
 - More than 32 feet wide, exclusive of shoulders (Parking permitted on both sides)

- Marking- approved signs, other approved notices or marking that include the words "NO PARKING-FIRE LANE shall be provided for fire apparatus access roads to identify such roads or prohibit the obstruction thereof. *CFC 503.3*

- Gates on access roads shall be a minimum width of 20 feet and shall comply with the following:
2016 CFC D103.5
 - Gates shall be of the swinging or sliding type.
 - Gates shall allow manual operation by one person (power outages).
 - Gates shall be maintained in an operative condition at all times.
 - Electric gates shall be equipped with a means of opening the gate by fire department personnel for emergency access. (Note: Knox boxes shall be ordered using an approved Knox Authorization Order Form. The forms are located at the fire department administration office located at 420 N Burke, Visalia, CA 93292. Please allow adequate time for shipping and installation.)

- Streets shall meet the City of Visalia's Design & Improvement Standards for streets to ensure that fire apparatus can make access to all structures in the event of an emergency.

Fire Protection Systems

- An automatic fire sprinkler system will be required for this building. Also, a fire hydrant is required within 50 feet of the Fire Department Connection (FDC). Where an existing building is retrofitted with a sprinkler system (NFPA 13 or NFPA 13R) a fire hydrant shall be provided within 75 feet of the FDC. An additional 25 feet of distance between a fire hydrant and FDC may be granted when a fire sprinkler Density is designed with an additional 25%. *2016 CFC 912 and Visalia Municipal Code 8.20.010 subsection C103.4*

- Locking fire department connection (FDC) caps are required. The caps shall be ordered using an approved Knox Authorization Order Form. The forms are located at the fire department administration office located at 420 N Burke, Visalia, CA 93292. *2016 CFC 912.4.1*

- Commercial cooking appliances and domestic cooking appliances used for commercial purposes that produces grease laden vapors shall be provided with a Type 1 Hood, in accordance with the California Mechanical Code, and an automatic fire extinguishing system. *2016 CFC 904.12 & 609.2*

Special Comments:



Danny Wrysten
Interim Fire Marshal

SPR-19-001

THE PAINTED LADY - TATTOO

**City of Visalia
Police Department**

303 S. Johnson St.
Visalia, Ca. 93292
(559) 713-4370

Site Plan Review Comments

- No Comment at this time.
- Request opportunity to comment or make recommendations as to safety issues as plans are developed.
- Public Safety Impact fee:
Ordinance No. 2001-11 Chapter 16.48 of Title 16 of the Visalia Municipal Code
Effective date - August 17, 2001

Impact fees shall be imposed by the City pursuant to this Ordinance as a condition of or in conjunction with the approval of a development project. "New Development or Development Project" means any new building, structure or improvement of any parcels of land, upon which no like building, structure of improvement previously existed. *Refer to Engineering Site Plan comments for fee estimation.

- Not enough information provided. Please provide additional information pertaining to:

- Territorial Reinforcement: Define property lines (private/public space).

- Access Controlled / Restricted etc:

Lighting Concerns:
ENSURE ADEQUATE LIGHTING

Landscaping Concerns:

Traffic Concerns:

Surveillance Issues:

Line of Sight Issues:

Other Concerns:
 A20

SITE PLAN REVIEW COMMENTS

CITY OF VISALIA TRAFFIC SAFETY DIVISION

January 9, 2019

ITEM NO. 3	RESUBMITTAL
SITE PLAN NO:	SPR19001
PROJECT TITLE:	The Painted Lady
DESCRIPTION:	By appointment only Tattoo (private) studio. (C-MU) (X)
APPLICANT:	Maegan La Roux
OWNER:	David Gonzalez
APN:	094-211-036
LOCATION:	213 S. Oakhurst St.

THE TRAFFIC DIVISION WILL PROHIBIT ON-STREET PARKING AS DEEMED NECESSARY

- No Comments
- See Previous Site Plan Comments
- Install Street Light(s) per City Standards.
- Install Street Name Blades at Locations.
- Install Stop Signs at Locations.
- Construct parking per City Standards PK-1 through PK-4.
- Construct drive approach per City Standards.
- Traffic Impact Analysis required.
- Provide more traffic information such as . Depending on development size, characteristics, etc., a TIA may be required.

Additional Comments:

•



Leslie Blair

CITY OF VISALIA
SOLID WASTE DIVISION
336 N. BEN MADDOX
VISALIA CA. 93291
713 - 4500

19001

COMMERCIAL BIN SERVICE

- No comments.
- See comments below
- Revisions required prior to submitting final plans. See comments below.
- Resubmittal required. See comments below.
- Customer responsible for all cardboard and other bulky recyclables to be broken down before disposing of in recycle containers
- ALL refuse enclosures must be R-3 OR R-4
- Customer must provide combination or keys for access to locked gates/bins
- Type of refuse service not indicated.
- Location of bin enclosure not acceptable. See comments below.
- Bin enclosure not to city standards double.
- Inadequate number of bins to provide sufficient service. See comments below.
- Drive approach too narrow for refuse trucks access. See comments below.
- Area not adequate for allowing refuse truck turning radius of : Commercial (X) 50 ft. outside 36 ft. inside; Residential () 35 ft. outside, 20 ft. inside.
- Paved areas should be engineered to withstand a 55,000 lb. refuse truck.
- Bin enclosure gates are required
- Hammerhead turnaround must be built per city standards.
- Cul - de - sac must be built per city standards.
- Bin enclosures are for city refuse containers only. Grease drums or any other items are not allowed to be stored inside bin enclosures.
- Area in front of refuse enclosure must be marked off indicating no parking
- Enclosure will have to be designed and located for a STAB service (DIRECT ACCESS) with no less than 38' clear space in front of the bin, included the front concrete pad.
- Customer will be required to roll container out to curb for service.
- Must be a concrete slab in front of enclosure as per city standards, the width of the enclosure by ten(10) feet, minimum of six(6) inches in depth.
- Roll off compactor's must have a clearance of 3 feet from any wall on both sides and there must be a minimum of 53 feet clearance in front of the compactor to allow the truck enough room to provide service.
- City ordinance 8.28.120-130 (effective 07/19/18) requires contractor to contract with City for removal of construction debris unless transported in equipment owned by contractor or unless contracting with a franchise permittee for removal of debris utilizing roll-off boxes.

Comment

Site Plan Review Comments For:

California Water Service Co.
Mike Morton, Superintendent
216 N. Valley Oaks Dr.
Visalia, CA 93292
559-624-1663 Office
559-735-3189 Fax

Date: 01/09/2019

Item # Choose an item.

Site Plan # 19001

Project: The Painted Lady

Description:

Applicant:

Location: 213 S. Oakhurst

APN:

The following comments are applicable when checked:

- No Comments at this time
- Fire Hydrants
Comments- Location to be approved by VFD and CWS. To be installed per CWS Spec's
- Service's
Comments- Service location to be determined by owner and approved by CWS. To be installed per CWS Spec's.
- Main's
Comments- Mains to be installed per CWS Spec's. Must provide adequate space for installation for proper separation of Storm Drain and Sewer to meet DDW requirements
- Back flow requirements
Comments- Backflow devices will be required on all services to property. Site survey will need to be performed

Additional Comments:

- Additional information required. When decided on type and size of services required contact CWS when ready to proceed.

Mike Morton
Superintendent

- Agriculture
- Business Research Park
- Conservation
- Commercial Mixed Use
- Commercial Neighborhood
- Commercial Regional
- Commercial Service
- Downtown Mixed Use
- Industrial
- Light Industrial
- Office
- Public Institutional
- Parks/Recreation
- Reserve
- Residential High Density
- Residential Low Density
- Residential Medium Density
- Residential Very Low Density

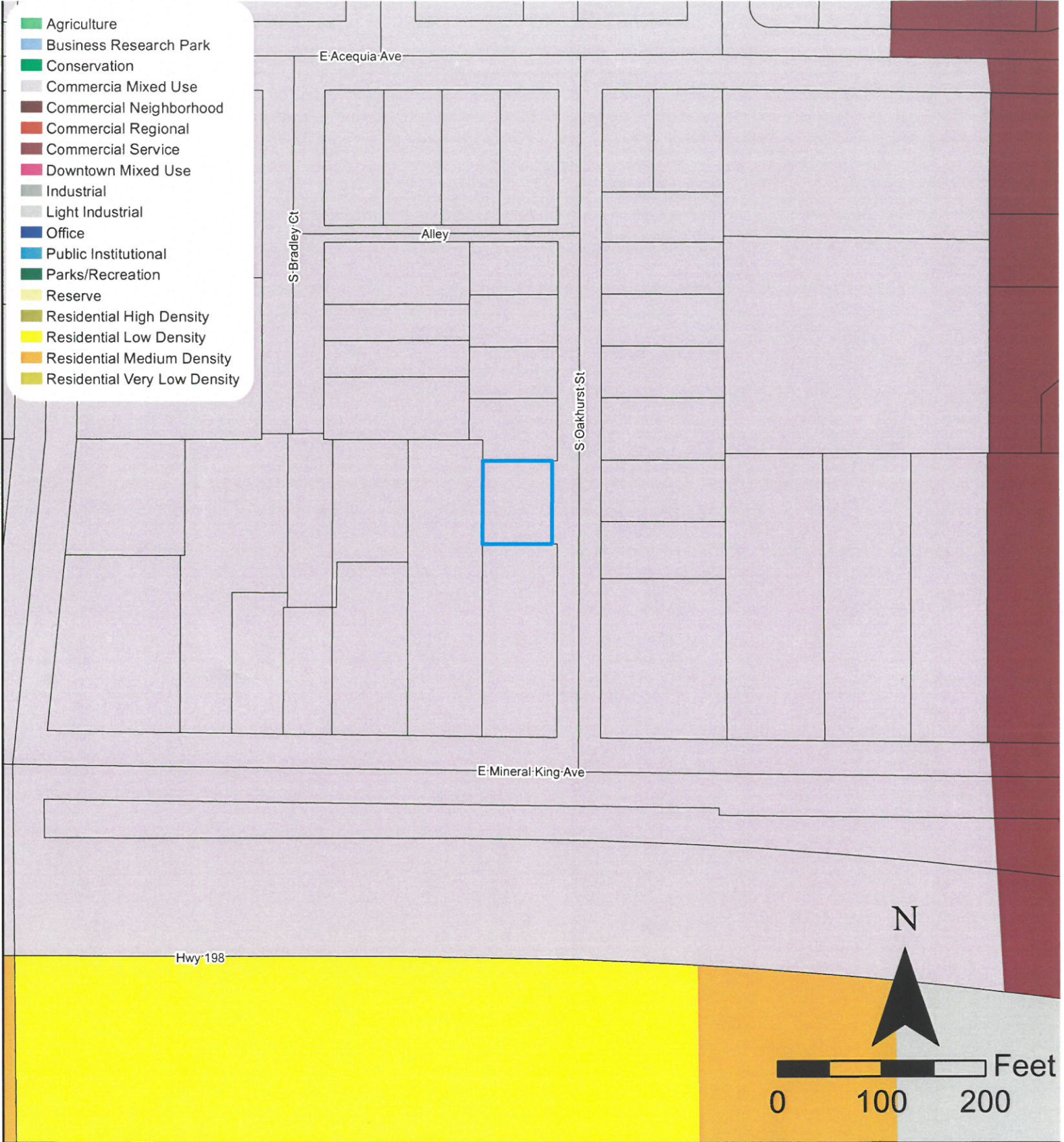

GENERAL PLAN LAND USE MAP

Legend

- City Limits
- Streets
- Parcels

- Agriculture
- Airport
- Business Research Park
- Neighborhood Commercial
- Regional Commercial
- Service Commercial
- Mixed Use Commercial
- Mixed Use Downtown
- Industrial
- Light Industrial
- Professional / Administrative Office
- Office Conversion
- Quasi-Public
- Open Space
- 20000 SF Min Site Area
- 12500 SF Min Site Area
- 5000 SF Min Site Area
- 3000 SF Min Site Area
- 1200 SF Min Site Area
- County Areas

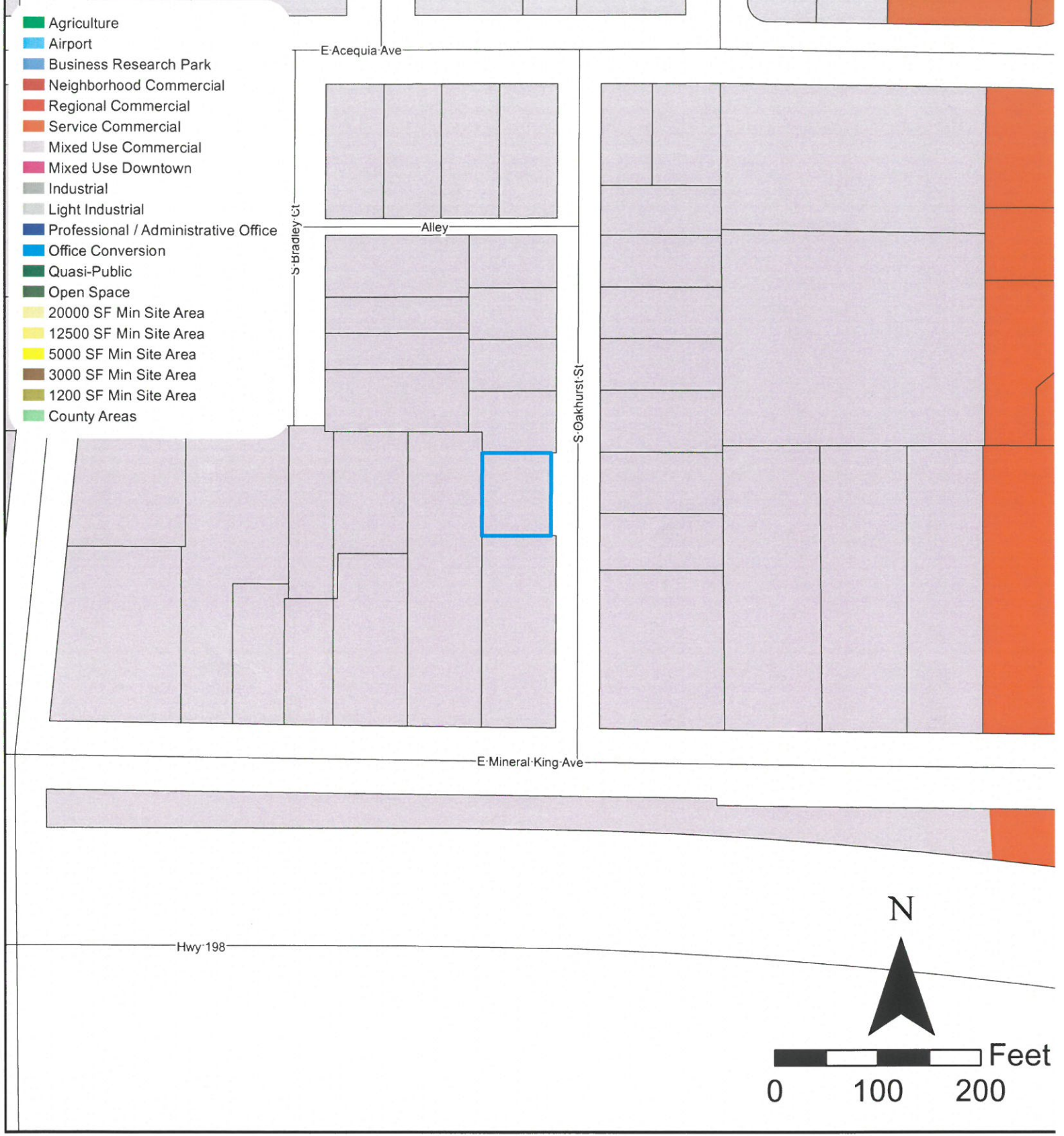

ZONING MAP

Legend

- City Limits
- Streets
- Parcels



Soakhurst St

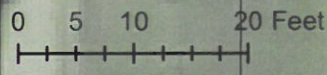

AERIAL MAP

Legend

-  City Limits
-  Streets
-  Parcels

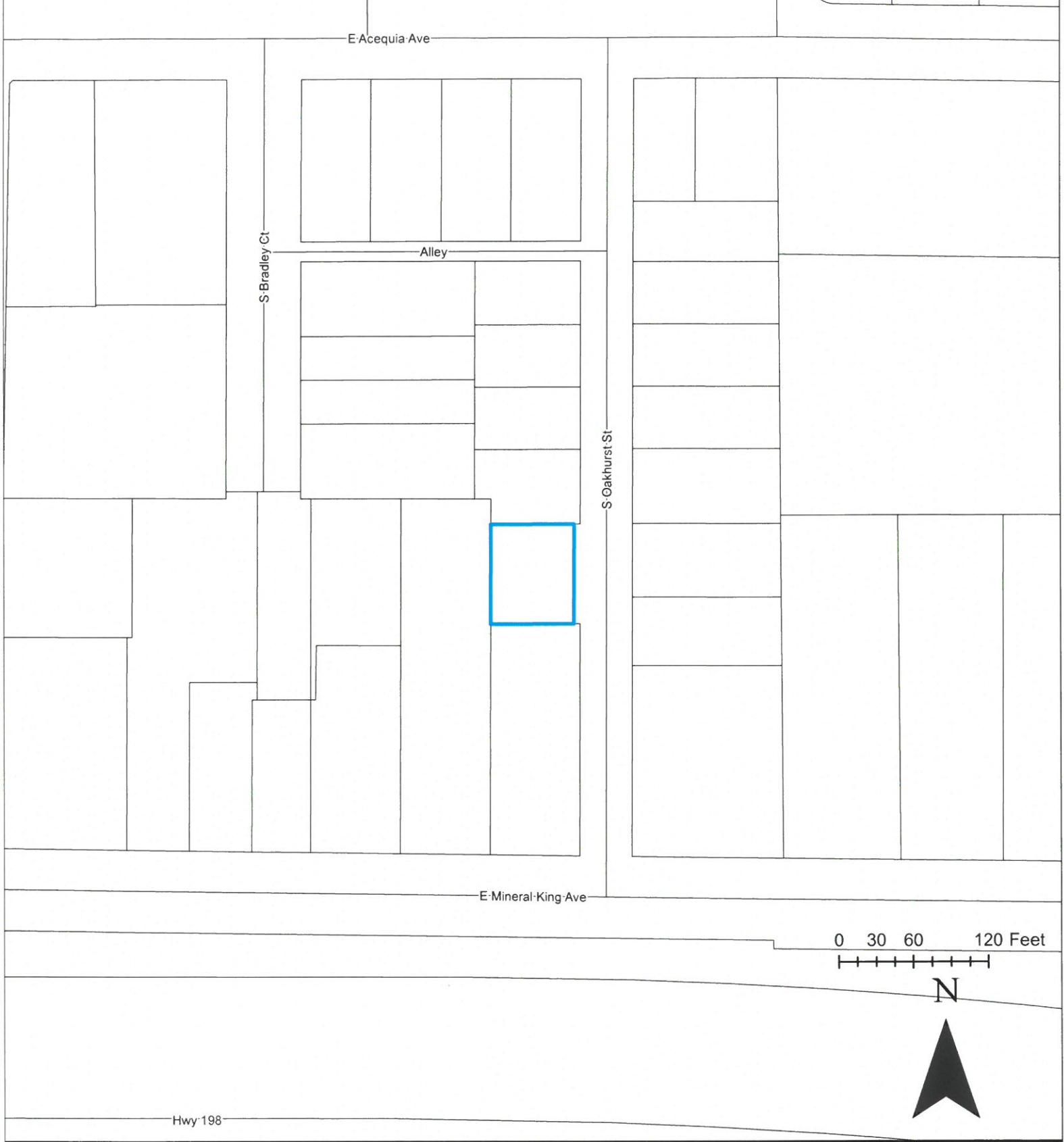

LOCATION MAP

Legend

-  City Limits
-  Streets
-  Parcels