

# PLANNING COMMISSION AGENDA

CHAIRPERSON:

Brett Taylor



VICE CHAIRPERSON:

Liz Wynn

COMMISSIONERS: Brett Taylor, Liz Wynn, Chris Gomez, Marvin Hansen, Sarrah Peariso

**MONDAY, FEBRUARY 25, 2019; 7:00 P.M., COUNCIL CHAMBERS, 707 W. ACEQUIA, VISALIA CA**

1. THE PLEDGE OF ALLEGIANCE –
2. CITIZEN'S COMMENTS – This is the time for citizens to comment on subject matters that are not on the agenda but are within the jurisdiction of the Visalia Planning Commission. The Commission requests that a 5-minute time limit be observed for comments. Please begin your comments by stating and spelling your name and city. Please note that issues raised under Citizen's Comments are informational only and the Commission will not take action at this time.
3. CHANGES OR COMMENTS TO THE AGENDA–
4. CONSENT CALENDAR - All items under the consent calendar are to be considered routine and will be enacted by one motion. For any discussion of an item on the consent calendar, it will be removed at the request of the Commission and made a part of the regular agenda.
  - Request to initiate a Zoning Text Amendment (ZTA) to allow Outpatient Surgery Center as a conditionally allowed use to Zoning Matrix Line M56
5. PUBLIC HEARING - Cristobal Carrillo  
Conditional Use Permit No. 2019-03: A request by Jeff Croall to establish an 8,000 sq. ft. dialysis clinic within an existing building in the O-PA (Professional/Administrative Office) Zone. The project site is located at 5300 W. Tulare Avenue (APN: 087-460-008). The project is Categorically Exempt from the California Environmental Quality Act (CEQA) pursuant to CEQA Guidelines Section 15301, Categorical Exemption No. 2019-05.
6. PUBLIC HEARING – Brandon Smith
  - a. Tentative Parcel Map No. 2018-04: A request by West End Partners, LLC to subdivide a 36,235 square foot parcel containing an existing commercial building into two commercial condominiums and a common site parcel, on land in the C-MU (Commercial Mixed Use) Zone. The project site is located on the southwest corner of Mooney Boulevard and Feemster Avenue (APN: 095-160-092). The project is Categorically Exempt from the California Environmental Quality Act (CEQA) pursuant to CEQA Guidelines Section 15301, Categorical Exemption No. 2018-72.
  - b. Conditional Use Permit No. 2018-29: A request by West End Partners, LLC to establish a planned commercial development with two commercial condominiums and a common site parcel on a developed commercial property, on land in the C-MU (Commercial Mixed Use) Zone. The project site is located on the southwest corner of Mooney Boulevard and Feemster Avenue (APN: 095-160-092). The project is Categorically Exempt from the California Environmental Quality Act (CEQA) pursuant to CEQA Guidelines Section 15301, Categorical Exemption No. 2018-72.

7. DIRECTOR'S REPORT/ PLANNING COMMISSION DISCUSSION-

- Visalia Planning Commission 2018 Annual Report to City Council
- Hurley Annexation Initiated by City Council
- City Council approved GPA/COZ/COZ for commercial building on Houston
- March 11, 2019 Planning Commission Meeting

The Planning Commission meeting may end no later than 11:00 P.M. Any unfinished business may be continued to a future date and time to be determined by the Commission at this meeting. The Planning Commission routinely visits the project sites listed on the agenda.

For Hearing Impaired – Call (559) 713-4900 (TTY) 48-hours in advance of the scheduled meeting time to request signing services.

Any written materials relating to an item on this agenda submitted to the Planning Commission after distribution of the agenda packet are available for public inspection in the City Office, 315 E. Acequia Visalia, CA 93291, during normal business hours.

**APPEAL PROCEDURE**

**THE LAST DAY TO FILE AN APPEAL IS THURSDAY, MARCH 6, 2019 BEFORE 5 PM**

According to the City of Visalia Zoning Ordinance Section 17.02.145 and Subdivision Ordinance Section 16.04.040, an appeal to the City Council may be submitted within ten days following the date of a decision by the Planning Commission. An appeal form with applicable fees shall be filed with the City Clerk at 220 N. Santa Fe, Visalia, CA 93292. The appeal shall specify errors or abuses of discretion by the Planning Commission, or decisions not supported by the evidence in the record. The appeal form can be found on the city's website [www.visalia.city](http://www.visalia.city) or from the City Clerk.

**THE NEXT REGULAR MEETING WILL BE HELD ON MONDAY, MARCH 11, 2019**



## REPORT TO CITY OF VISALIA PLANNING COMMISSION

**HEARING DATE:** February 25, 2019

**PROJECT PLANNER:** Brandon Smith, Senior Planner  
Phone No: (559) 713-4636;  
E-mail: [brandon.smith@visalia.city](mailto:brandon.smith@visalia.city)

**SUBJECT: Tentative Parcel Map No. 2018-04:** A request by West End Partners, LLC to subdivide a 36,235 square foot parcel containing an existing commercial building into two commercial condominiums and a common site parcel, on land in the C-MU (Commercial Mixed Use) Zone. The project site is located on the southwest corner of Mooney Boulevard and Feemster Avenue. (APN: 095-160-092)

**Conditional Use Permit No. 2018-29:** A request by West End Partners, LLC to establish a planned commercial development with two commercial condominiums and a common site parcel on a developed commercial property, on land in the C-MU (Commercial Mixed Use) Zone. The project site is located on the southwest corner of Mooney Boulevard and Feemster Avenue. (APN: 095-160-092)

### STAFF RECOMMENDATION

Staff recommends approval of Tentative Parcel Map No. 2018-04 and Conditional Use Permit No 2018-29, as conditioned, based on the findings and conditions in Resolution Nos. 2018-57 and 2018-58. Staff's recommendation is based on the conclusion that the request is consistent with the Visalia General Plan, Zoning and Subdivision Ordinances.

### RECOMMENDED MOTION

I move to approve Tentative Parcel Map No. 2018-04 and Conditional Use Permit No. 2018-29, based on the findings and conditions in Resolution Nos. 2018-57 and 2018-58.

### PROJECT DESCRIPTION

The project applicant is requesting approval of a tentative parcel map and conditional use permit to allow an air-space condominium conversion to an existing 8,349 sq. ft. commercial building located at 1501 S. Mooney Boulevard (see attached Exhibit "A" for site plan and parcel map). The proposed condominium plan is included as Exhibits "B" and "D".

The locations of the three-dimensional airspace conversions are Unit 1 (comprising Suite 101 of 1501 S. Mooney Blvd.) and Unit 2 (comprising Suites 102 and 103), illustrated on the unit detail sheet of the condominium plan attached as Exhibits "B" and "D". The remaining area associated with the project site (i.e. landscaping, parking lot, trash enclosure, etc.) is represented by common area Parcel "A". Common areas and facilities accessible to the public will be maintained under a common area property association as described in a Declaration of Restrictions provided by the applicant to be recorded with the condominium plan. Exhibit "A" shows the common area parking lot and existing trash enclosure which will be maintained by the common area property association. No physical improvements such as additions or

alterations to the site are being requested for the common area as part of this project. The property completed extensive site improvements over the last two years.

The Visalia Zoning Ordinance allows planned developments with parcels that do not conform to zoning standards as a conditional use. The Zoning Ordinance does not contain standards or policies which pertain directly to condominium conversions. Condominium conversions are subject to the Subdivision Map Act (State Government Code Section 66427.1) and administered by the State Department of Real Estate.

## **BACKGROUND INFORMATION**

General Plan Land Use Designation:	Commercial Mixed Use
Zoning:	C-MU (Commercial Mixed Use)
Surrounding Land Use and Zoning:	North: C-MU / Feemster Avenue, office buildings South: C-MU / Office buildings East: C-MU / Mooney Blvd., commercial buildings West: C-MU / Office buildings
Environmental Review:	Categorical Exemption No. 2018-72
Special Districts:	N/A
Site Plan Review No:	2018-140

### **RELATED PLANS & POLICIES**

The Subdivision Map Act contains policies which pertain to condominium conversions. An excerpt of this text is included at the end of this report.

### **RELATED ACTIONS**

The City last processed an entitlement for a commercial / office space condominium in 2009, when the Planning Commission approved Tentative Parcel Map No. 2009-01 and Conditional Use Permit No. 2009-21 on April 27, 2009. The project created six air-space parcels and three common area parcels on the site of an existing office building in the C-DT (Central Business District Retail) zone at 525 W. Main Street.

## **PROJECT EVALUATION**

Staff recommends approval of the requested Tentative Parcel Map and Conditional Use Permit based on the project's consistency with the General Plan, Zoning and Subdivision Ordinances.

### **Access, Circulation, and Parking**

On-site parking for the development is accessed directly from Mooney Boulevard and Feemster Avenue, and consists of uncovered parking stalls. Current zoning standards require that commercial buildings provide one parking space per 300 square feet of floor area. The building has a total lease area of 8,349 square feet, which requires 28 parking stalls. The site has a total of 46 constructed on-site parking stalls. According to the declaration of restrictions, parking stalls are for the use of all tenants.

**Solid Waste**

The project’s solid waste service will continue with the usage of a commercial trash enclosure bin as shown in Exhibit “A”.

**Property Owners’ Association**

The project applicant has chosen to establish a common area property association which will assume responsibility and maintenance for all common areas associated with the project. Since the converted units will be air space condominiums, common areas will generally include any spaces located outside of the private interior space of the units such as the insides of common walls, plumbing, pipes, and electrical lines inside the common walls, subfloors, and roofs. A Declaration of Covenants, Conditions, Restriction, and Reservation of Easements (CC&Rs) shall be recorded in association with the development and shall establish responsibilities to be held by the property owner(s) and responsibilities to be held by the association. The applicant has provided a draft un-recorded copy of the CC&Rs with the project application. It is not included as an attachment to this report.

Staff recommends that a condition be placed with the project which requires a property owners’ association to be created and become effective for this project and assume responsibility for all common grounds and improvements, including landscaping, fences, driveways, roofs, and public utilities.

**Subdivision Map Act Requirements**

According to Section §66427.1 of the California Government Code, the legislating body which approves a final map of a subdivision causing a condominium conversion (or, the City Council for the City of Visalia) must be able to make certain findings regarding the notification of tenants by the applicant. The Planning Commission, as the legislative body charged with approving the tentative map, is not required to make any specific findings pertaining to notification or consistency when approving a tentative map or conditional use permit causing a condominium conversion.

**Subdivision Map Act Findings**

California Government Code Section §66474 lists seven findings for which a legislative body of a city or county shall deny approval of a tentative map if it is able to make any of these findings. These seven “negative” findings have come to light through a recent California Court of Appeal decision (*Spring Valley Association v. City of Victorville*) that has clarified the scope of findings that a city or county must make when approving a tentative map under the California Subdivision Map Act.

Staff has reviewed the seven findings for a cause of denial and finds that none of the findings can be made for the proposed project. The seven findings and staff’s analysis are below. Recommended findings in response to this Government Code section are included in the recommended findings for the approval of the tentative parcel map.

<u>GC Section 66474 Finding</u>	<u>Analysis</u>
(a) That the proposed map is not consistent with applicable general and specific plans as specified in Section 65451.	The proposed map has been found to be consistent with the City’s General Plan. This is included as recommended Finding No. 1 of the Tentative Parcel Map. There are no specific plans applicable to the proposed map.
(b) That the design or improvement of the proposed subdivision is not	The proposed design and improvement of the map

consistent with applicable general and specific plans.	has been found to be consistent with the City's General Plan. This is included as recommended Finding No. 1 of the Tentative Parcel Map. There are no specific plans applicable to the proposed map.
(c) That the site is not physically suitable for the type of development.	The site is physically suitable for the proposed map and its affiliated development plan, which is designated as Commercial land use. This is included as recommended Finding No. 4 of the Tentative Parcel Map.
(d) That the site is not physically suitable for the proposed density of development.	The site is physically suitable for the proposed density of development in the Commercial land use designation and C-MU zone, which specifies floor area ratios ranging between 0.25 and 2.0. This is included as recommended Finding No. 5 of the Tentative Parcel Map.
(e) That the design of the subdivision or the proposed improvements are likely to cause substantial environmental damage or substantially and avoidably injure fish or wildlife or their habitat.	The proposed design and improvement of the map has been not been found likely to cause environmental damage or substantially and avoidable injure fish or wildlife or their habitat. This finding is further supported by the project's Categorical Exemption determination under Section 15301 of the Guidelines for the Implementation of the California Environmental Quality Act (CEQA), included as recommended Finding No. 3 of the Tentative Parcel Map.
(f) That the design of the subdivision or type of improvements is likely to cause serious public health problems.	The proposed design of the map has been found to not cause serious public health problems. This is included as recommended Finding No. 2 of the Tentative Parcel Map.
(g) That the design of the subdivision or the type of improvements will conflict with easements, acquired by the public at large, for access through or use of, property within the proposed subdivision.	The proposed design of the map does not conflict with any existing or proposed easements located on or adjacent to the subject property. This is included as recommended Finding No. 6 of the Tentative Parcel Map.

### **Environmental Review**

The project is considered Categorical Exempt under Section 15301(k) of the Guidelines for the Implementation of the California Environmental Quality Act (CEQA), as amended (Categorical Exemption No. 2018-72). Section 15301 includes exemptions to existing structures, and sub-section (k) specifically refers to the subdivision of existing commercial structures where no physical improvements are occurring.

## RECOMMENDED FINDINGS

### **Tentative Parcel Map No. 2018-04**

1. That the proposed location and layout of the tentative parcel map, its improvement and design, and the conditions under which it will be maintained is consistent with the policies and intent of the General Plan, Zoning Ordinance, and Subdivision Ordinance.
2. That the proposed tentative parcel map, its improvement and design, and the conditions under which it will be maintained will not be detrimental to the public health, safety, or welfare, nor materially injurious to properties or improvements in the vicinity, nor is it likely to cause serious public health problems.
3. That the project is considered Categorical Exempt under Section 15301 of the Guidelines for the Implementation of the California Environmental Quality Act (CEQA) (Categorical Exemption No. 2018-72). Furthermore, the design of the subdivision or the proposed improvements is not likely to neither cause substantial environmental damage nor substantially and avoidably injure fish or wildlife or their habitat.
4. That the site is physically suitable for the proposed tentative parcel map and the way that it will be improved and developed through the accompanying planned development (Conditional Use Permit No. 2018-29).
5. That the site is physically suitable for the proposed tentative parcel map and the project's density, which is consistent with the underlying Commercial land use designation and zone, which specifies floor area ratios ranging between 0.25 and 2.0.
6. That the proposed tentative parcel map, design of the subdivision or the type of improvements will not conflict with easements, acquired by the public at large, for access through or use of, property within the proposed subdivision.
7. That the proposed parcel sizes resulting from the parcel map are consistent with the Zoning Ordinance's Planned Development and Commercial zone standards since they are part of a planned development established through Conditional Use Permit No. 2018-29.

### **Conditional Use Permit No. 2018-29**

1. That the proposed project, as conditioned, will not be detrimental to the public health, safety, or welfare, or materially injurious to properties or improvements in the vicinity.
2. That the proposed conditional use permit is consistent with the policies and intent of the General Plan and Zoning Ordinance. Specifically, the project is consistent with the required findings of Zoning Ordinance Section 17.38.110:
  - The proposed location of the conditional use is in accordance with the objectives of the Zoning Ordinance and the purposes of the zone in which the site is located.
  - The proposed location of the conditional use and the conditions under which it would be operated or maintained will not be detrimental to the public health, safety, or welfare, nor materially injurious to properties or improvements in the vicinity.
3. That the proposed parcel sizes resulting from the planned development are consistent with the Zoning Ordinance's Planned Development and Commercial zone standards based on the creation of a master development plan.
4. That the project is considered Categorical Exempt under Section 15301 of the Guidelines for the Implementation of the California Environmental Quality Act (CEQA) (Categorical Exemption No. 2018-72).

## **RECOMMENDED CONDITIONS OF APPROVAL**

### **Tentative Parcel Map No. 2018-04**

1. That the site be developed consistent with the comments and conditions of the Site Plan Review Committee as set forth under Site Plan No. 2018-140.
2. That the final map be carried out in substantial compliance with the approved tentative parcel map shown in Exhibit "A", attached herein.
3. That Tentative Parcel Map No. 2018-04 shall be null and void unless Conditional Use Permit No. 2018-29 is approved.
4. That before recordation of a final map or issuance of building permit, whichever comes first, a common property owners association shall be established for the long term maintenance and management of the project. This association shall establish responsibility for but not limited to the following:
  - a. The maintenance of roofs and subfloors,
  - b. The maintenance of spaces located outside of the private interior space of the units, including the insides of common walls, plumbing, pipes, and electrical lines,
  - c. The maintenance of landscaping for the associated properties,
  - d. The maintenance of on-site parking and driveways,
  - e. The maintenance of the fences, on-site lighting and other improvements that are not along the public street frontages,
  - f. The maintenance of the common open space areas;
  - g. Enforcing all provisions covered by covenants, conditions and restrictions that are placed on the property.
5. That the form of the common property owners association bylaws, including covenants, condition, and restrictions (CC&Rs), shall be approved by the State Department of Real Estate and the City Planner. The bylaws' final approved form shall be recorded with the Tulare County Recorder.
6. That all other federal, state, regional, and local laws and city codes and ordinances be complied with.

### **Conditional Use Permit No. 2018-29**

1. That the site be developed consistent with the comments and conditions of the Site Plan Review Committee as set forth under Site Plan No. 2018-140.
2. That the final map be carried out in substantial compliance with the approved condominium plan shown in Exhibit "B", attached herein.
3. That Conditional Use Permit No. 2018-29 shall be null and void unless Tentative Parcel Map No. 2018-04 is approved.
4. That before recordation of a final map or issuance of building permit, whichever comes first, a common property owners association shall be established for the long term maintenance and management of the project. This association shall establish responsibility for but not limited to the following:
  - a. The maintenance of roofs and subfloors,
  - b. The maintenance of spaces located outside of the private interior space of the units, including the insides of common walls, plumbing, pipes, and electrical lines,
  - c. The maintenance of landscaping for the associated properties,
  - d. The maintenance of on-site parking and driveways,



- e. The maintenance of the fences, on-site lighting and other improvements that are not along the public street frontages,
  - f. The maintenance of the common open space areas;
  - g. Enforcing all provisions covered by covenants, conditions and restrictions that are placed on the property
5. That the form of the common property owners association bylaws, including covenants, condition, and restrictions (CC&Rs), shall be approved by the State Department of Real Estate and the City Planner. The bylaws' final approved form shall be recorded with the Tulare County Recorder.
  6. That all other federal, state, regional, and local laws and city codes and ordinances be complied with.

## **APPEAL INFORMATION**

According to the City of Visalia Zoning Ordinance Section 17.02.145 and Subdivision Ordinance Section 16.28.080, an appeal to the City Council may be submitted within ten days following the date of a decision by the Planning Commission. An appeal with applicable fees shall be in writing and shall be filed with the City Clerk at 220 N. Santa Fe Street, Visalia, CA 93292. The appeal shall specify errors or abuses of discretion by the Planning Commission, or decisions not supported by the evidence in the record. The appeal form can be found on the city's website [www.visalia.city](http://www.visalia.city) or from the City Clerk.

### **Attachments:**

- Related Plans & Policies
- Resolution No. 2018-58 (Tentative Parcel Map No. 2018-04)
- Resolution No. 2018-57 (Conditional Use Permit No. 2018-29)
- Exhibit "A" – Tentative Parcel Map / Site Plan
- Exhibit "B" – Condominium Plan
- Exhibit "C" – Overall site plan illustrating suite divisions
- Exhibit "D" – Proposed Commercial Condominium Plan
- Exhibit "E" – Existing Floor Plan
- Site Plan Review Item No. 2018-140 Comments
- General Plan Land Use Map
- Zoning Map
- Aerial Map
- Vicinity Map

## RELATED PLANS AND POLICIES

### **Subdivision Map Act (California Government Code Section 66410 – 66499.38)**

The following are excerpts from the California Government Code which pertain to approvals of tentative and final maps which pertain to condominium conversions:

#### **66427.**

(a) A map of a condominium project, a community apartment project, or of the conversion of five or more existing dwelling units to a stock cooperative project need not show the buildings or the manner in which the buildings or the airspace above the property shown on the map are to be divided, nor shall the governing body have the right to refuse approval of a parcel, tentative, or final map of the project on account of the design or the location of buildings on the property shown on the map that are not violative of local ordinances or on account of the manner in which airspace is to be divided in conveying the condominium.

(b) A map need not include a condominium plan or plans, as defined in Section 4120 or 6540 of the Civil Code, and the governing body may not refuse approval of a parcel, tentative, or final map of the project on account of the absence of a condominium plan.

(c) Fees and lot design requirements shall be computed and imposed with respect to those maps on the basis of parcels or lots of the surface of the land shown thereon as included in the project.

(d) Nothing herein shall be deemed to limit the power of the legislative body to regulate the design or location of buildings in a project by or pursuant to local ordinances.

(e) If the governing body has approved a parcel map or final map for the establishment of condominiums on property pursuant to the requirements of this division, the separation of a three-dimensional portion or portions of the property from the remainder of the property or the division of that three-dimensional portion or portions into condominiums shall not constitute a further subdivision as defined in Section 66424, provided each of the following conditions has been satisfied:

(1) The total number of condominiums established is not increased above the number authorized by the local agency in approving the parcel map or final map.

(2) A perpetual estate or an estate for years in the remainder of the property is held by the condominium owners in undivided interests in common, or by an association as defined in Section 4100 or 6528 of the Civil Code, and the duration of the estate in the remainder of the property is the same as the duration of the estate in the condominiums.

(3) The three-dimensional portion or portions of property are described on a condominium plan or plans, as defined in Section 4120 or 6540 of the Civil Code.

*(Amended (as amended by Stats. 2012, Ch. 181, Sec. 58) by Stats. 2013, Ch. 605, Sec. 32. (SB 752) Effective January 1, 2014.)*

#### **66427.1.**

(a) The legislative body shall not approve a final map for a subdivision to be created from the conversion of residential real property into a condominium project, a community apartment project, or a stock cooperative project, unless it finds as follows:

(1) Each tenant of the proposed condominium, community apartment project, or stock cooperative project, and each person applying for the rental of a unit in the residential real property, has received or will have received all applicable notices and rights now or hereafter required by this chapter or Chapter 3 (commencing with Section 66451).

(2) Each of the tenants of the proposed condominium, community apartment project, or stock cooperative project has received or will receive each of the following notices:

(A) Written notification, pursuant to Section 66452.18, of intention to convert, provided at least 60 days prior to the filing of a tentative map pursuant to Section 66452.

(B) Ten days' written notification that an application for a public report will be, or has been, submitted to the Bureau of Real Estate, that the period for each tenant's right to purchase begins with the issuance of the final public report, and that the report will be available on request.

(C) Written notification that the subdivider has received the public report from the Bureau of Real Estate. This notice shall be provided within five days after the date that the subdivider receives the public report from the Bureau of Real Estate.

(D) Written notification within 10 days after approval of a final map for the proposed conversion.

(E) One hundred eighty days' written notice of intention to convert, provided prior to termination of tenancy due to the conversion or proposed conversion pursuant to Section 66452.19, but not before the local authority has approved a tentative map for the conversion. The notice given pursuant to this paragraph shall not alter or abridge the rights or obligations of the parties in performance of their covenants, including, but not limited to, the provision of services, payment of rent, or the obligations imposed by Sections 1941, 1941.1, and 1941.2 of the Civil Code.

(F) Notice of an exclusive right to contract for the purchase of his or her respective unit upon the same terms and conditions that the unit will be initially offered to the general public or terms more favorable to the tenant pursuant to Section 66452.20. The exclusive right to purchase shall commence on the date the subdivision public report is issued, as provided in Section 11018.2 of the Business and Professions Code, and shall run for a period of not less than 90 days, unless the tenant gives prior written notice of his or her intention not to exercise the right.

(b) The written notices to tenants required by subparagraphs (A) and (B) of paragraph (2) of subdivision (a) shall be deemed satisfied if those notices comply with the legal requirements for service by mail.

(c) This section shall not diminish, limit, or expand, other than as provided in this section, the authority of any city, county, or city and county to approve or disapprove condominium projects.

(d) If a rental agreement was negotiated in Spanish, Chinese, Tagalog, Vietnamese, or Korean, all required written notices regarding the conversion of residential real property into a condominium project, a community apartment project, or a stock cooperative project shall be issued in that language.

*(Amended by Stats. 2013, Ch. 352, Sec. 313. (AB 1317) Effective September 26, 2013. Operative July 1, 2013, by Sec. 543 of Ch. 352.)*

#### **66427.2.**

Unless applicable general or specific plans contain definite objectives and policies, specifically directed to the conversion of existing buildings into condominium projects or stock cooperatives, the provisions of Sections 66473.5, 66474, and 66474.61, and subdivision (c) of Section 66474.60 shall not apply to condominium projects or stock cooperatives, which consist of the subdivision of airspace in an existing structure, unless new units are to be constructed or added.

A city, county, or city and county acting pursuant to this section shall approve or disapprove the conversion of an existing building to a stock cooperative within 120 days following receipt of a completed application for approval of such conversion.

This section shall not diminish, limit or expand, other than as provided herein, the authority of any city, county, or city and county to approve or disapprove condominium projects.

*(Amended by Stats. 1979, Ch. 1192.)*

RESOLUTION NO. 2018-58

A RESOLUTION OF THE PLANNING COMMISSION OF THE CITY OF VISALIA APPROVING TENTATIVE PARCEL MAP NO. 2018-04: A REQUEST BY WEST END PARTNERS, LLC TO SUBDIVIDE A 36,235 SQUARE FOOT PARCEL CONTAINING AN EXISTING COMMERCIAL BUILDING INTO TWO COMMERCIAL CONDOMINIUMS AND A COMMON SITE PARCEL, ON LAND IN THE C-MU (COMMERCIAL MIXED USE) ZONE. THE PROJECT SITE IS LOCATED ON THE SOUTHWEST CORNER OF MOONEY BOULEVARD AND FEEMSTER AVENUE. (APN: 095-160-092)

**WHEREAS**, Tentative Parcel Map No. 2018-04 is a request by West End Partners, LLC to subdivide a 36,235 square foot parcel containing an existing commercial building into two commercial condominiums and a common site parcel, on land in the C-MU (Commercial Mixed Use) Zone. The project site is located on the southwest corner of Mooney Boulevard and Feemster Avenue (APN: 095-160-092); and,

**WHEREAS**, the Planning Commission of the City of Visalia, after duly published notice did hold a public hearing before said Commission on February 25, 2019; and,

**WHEREAS**, the Planning Commission of the City of Visalia finds Tentative Parcel Map No. 2018-04, as conditioned, in accordance with Section 16.28.070 of the Ordinance Code of the City of Visalia based on the evidence contained in the staff report and testimony presented at the public hearing; and,

**WHEREAS**, the project is considered Categorically Exempt under Section 15301 of the Guidelines for the Implementation of the California Environmental Quality Act (CEQA) (Categorical Exemption No. 2018-72).

**NOW, THEREFORE, BE IT RESOLVED**, that the Planning Commission of the City of Visalia makes the following specific findings based on the evidence presented:

1. That the proposed location and layout of the tentative parcel map, its improvement and design, and the conditions under which it will be maintained is consistent with the policies and intent of the General Plan, Zoning Ordinance, and Subdivision Ordinance.
2. That the proposed tentative parcel map, its improvement and design, and the conditions under which it will be maintained will not be detrimental to the public health, safety, or welfare, nor materially injurious to properties or improvements in the vicinity, nor is it likely to cause serious public health problems.

3. That the project is considered Categorically Exempt under Section 15301 of the Guidelines for the Implementation of the California Environmental Quality Act (CEQA) (Categorical Exemption No. 2018-72). Furthermore, the design of the subdivision or the proposed improvements is not likely to neither cause substantial environmental damage nor substantially and avoidably injure fish or wildlife or their habitat.
4. That the site is physically suitable for the proposed tentative parcel map and the way that it will be improved and developed through the accompanying planned development (Conditional Use Permit No. 2018-29).
5. That the site is physically suitable for the proposed tentative parcel map and the project's density, which is consistent with the underlying Commercial land use designation and zone, which specifies floor area ratios ranging between 0.25 and 2.0.
6. That the proposed tentative parcel map, design of the subdivision or the type of improvements will not conflict with easements, acquired by the public at large, for access through or use of, property within the proposed subdivision.
7. That the proposed parcel sizes resulting from the parcel map are consistent with the Zoning Ordinance's Planned Development and Commercial zone standards since they are part of a planned development established through Conditional Use Permit No. 2018-29.

**BE IT FURTHER RESOLVED** that the Planning Commission hereby approves the Tentative Parcel Map on the real property hereinabove described in accordance with the terms of this resolution under the provisions of Section 16.28.070 of the Ordinance Code of the City of Visalia, subject to the following conditions:

1. That the site be developed consistent with the comments and conditions of the Site Plan Review Committee as set forth under Site Plan No. 2018-140.
2. That the final map be carried out in substantial compliance with the approved tentative parcel map shown in Exhibit "A", attached herein.
3. That Tentative Parcel Map No. 2018-04 shall be null and void unless Conditional Use Permit No. 2018-29 is approved.
4. That before recordation of a final map or issuance of building permit, whichever comes first, a common property owners association shall be established for the long term maintenance and management of the project. This association shall establish responsibility for but not limited to the following:
  - a. The maintenance of roofs and subfloors,
  - b. The maintenance of spaces located outside of the private interior space of the units, including the insides of common walls, plumbing, pipes, and electrical lines,
  - c. The maintenance of landscaping for the associated properties,
  - d. The maintenance of on-site parking and driveways,

- e. The maintenance of the fences, on-site lighting and other improvements that are not along the public street frontages,
  - f. The maintenance of the common open space areas;
  - g. Enforcing all provisions covered by covenants, conditions and restrictions that are placed on the property.
5. That the form of the common property owners association bylaws, including covenants, condition, and restrictions (CC&Rs), shall be approved by the State Department of Real Estate and the City Planner. The bylaws' final approved form shall be recorded with the Tulare County Recorder.
6. That all other federal, state, regional, and local laws and city codes and ordinances be complied with.

RESOLUTION NO. 2018-57

A RESOLUTION OF THE PLANNING COMMISSION OF THE CITY OF VISALIA APPROVING CONDITIONAL USE PERMIT NO. 2018-29: A REQUEST BY WEST END PARTNERS, LLC TO ESTABLISH A PLANNED COMMERCIAL DEVELOPMENT WITH TWO COMMERCIAL CONDOMINIUMS AND A COMMON SITE PARCEL ON A DEVELOPED COMMERCIAL PROPERTY, ON LAND IN THE C-MU (COMMERCIAL MIXED USE) ZONE. THE PROJECT SITE IS LOCATED ON THE SOUTHWEST CORNER OF MOONEY BOULEVARD AND FEEMSTER AVENUE. (APN: 095-160-092)

**WHEREAS**, Conditional Use Permit No. 2018-29 is a request by West End Partners, LLC to establish a planned commercial development with two commercial condominiums and a common site parcel on a developed commercial property, on land in the C-MU (Commercial Mixed Use) Zone. The project site is located on the southwest corner of Mooney Boulevard and Feemster Avenue (APN: 095-160-092); and

**WHEREAS**, the Planning Commission of the City of Visalia, after duly published notice did hold a public hearing before said Commission on February 25, 2019; and

**WHEREAS**, the Planning Commission of the City of Visalia finds Conditional Use Permit No. 2018-29, as conditioned, to be in accordance with Chapter 17.38.110 of the Zoning Ordinance of the City of Visalia based on the evidence contained in the staff report and testimony presented at the public hearing; and

**WHEREAS**, the project is considered Categorical Exempt under Section 15301 of the Guidelines for the Implementation of the California Environmental Quality Act (CEQA) (Categorical Exemption No. 2018-72).

**NOW, THEREFORE, BE IT RESOLVED** that the Planning Commission of the City of Visalia makes the following specific findings based on the evidence presented:

1. That the proposed project, as conditioned, will not be detrimental to the public health, safety, or welfare, or materially injurious to properties or improvements in the vicinity.
2. That the proposed conditional use permit is consistent with the policies and intent of the General Plan and Zoning Ordinance. Specifically, the project is consistent with the required findings of Zoning Ordinance Section 17.38.110:
  - The proposed location of the conditional use is in accordance with the objectives of the Zoning Ordinance and the purposes of the zone in which the site is located.
  - The proposed location of the conditional use and the conditions under which it would be operated or maintained will not be detrimental to the public health, safety, or welfare, nor materially injurious to properties or improvements in the vicinity.

3. That the proposed parcel sizes resulting from the planned development are consistent with the Zoning Ordinance's Planned Development and Commercial zone standards based on the creation of a master development plan.
4. That the project is considered Categorical Exempt under Section 15301 of the Guidelines for the Implementation of the California Environmental Quality Act (CEQA) (Categorical Exemption No. 2018-72).

**BE IT FURTHER RESOLVED** that the Planning Commission hereby approves the Conditional Use Permit on the real property here described in accordance with the terms of this resolution under the provisions of Section 17.38.110 of the Ordinance Code of the City of Visalia, subject to the following conditions:

1. That the site be developed consistent with the comments and conditions of the Site Plan Review Committee as set forth under Site Plan No. 2018-140.
2. That the final map be carried out in substantial compliance with the approved condominium plan shown in Exhibit "B", attached herein.
3. That Conditional Use Permit No. 2018-29 shall be null and void unless Tentative Parcel Map No. 2018-04 is approved.
4. That before recordation of a final map or issuance of building permit, whichever comes first, a common property owners association shall be established for the long term maintenance and management of the project. This association shall establish responsibility for but not limited to the following:
  - a. The maintenance of roofs and subfloors,
  - b. The maintenance of spaces located outside of the private interior space of the units, including the insides of common walls, plumbing, pipes, and electrical lines,
  - c. The maintenance of landscaping for the associated properties,
  - d. The maintenance of on-site parking and driveways,
  - e. The maintenance of the fences, on-site lighting and other improvements that are not along the public street frontages,
  - f. The maintenance of the common open space areas;
  - g. Enforcing all provisions covered by covenants, conditions and restrictions that are placed on the property.
5. That the form of the common property owners association bylaws, including covenants, condition, and restrictions (CC&Rs), shall be approved by the State Department of Real Estate and the City Planner. The bylaws' final approved form shall be recorded with the Tulare County Recorder.
6. That all other federal, state, regional, and local laws and city codes and ordinances be complied with.



# TENTATIVE PARCEL MAP NO. 2018-04 FOR CONDOMINIUM PURPOSES

## LEGAL DESCRIPTION

That portion of the East half of the Northeast Quarter of Section 36, Township 18 South, Range 24 East, Mount Diablo Base and Meridian, in the City of Visalia, County of Tulare, State of California, described as follows:  
Commencing at a point on the East line of the Southeast Quarter of said Section 36, a distance of 997.51 feet, South 0° 01' 00" West of the Northeast corner thereof; thence West 55 feet to the North line of said Section 36, a distance of 136.50 feet, North 30° 00' 00" West of the Northeast corner thereof; thence West 20 feet and a chord which bears North 44° 59' 30" West, 79.29 feet, thence West 136.50 feet to a point that is 327.965 feet West of a point on the East line of the Southeast Quarter of said Section, distant 1084.00 feet South 0° 01' 00" West of the Northeast corner thereof; thence East 272.955 feet, thence North 115.49 feet to the true point of beginning. 2007 as Instrument No. 2007-0020898 of Official Records.

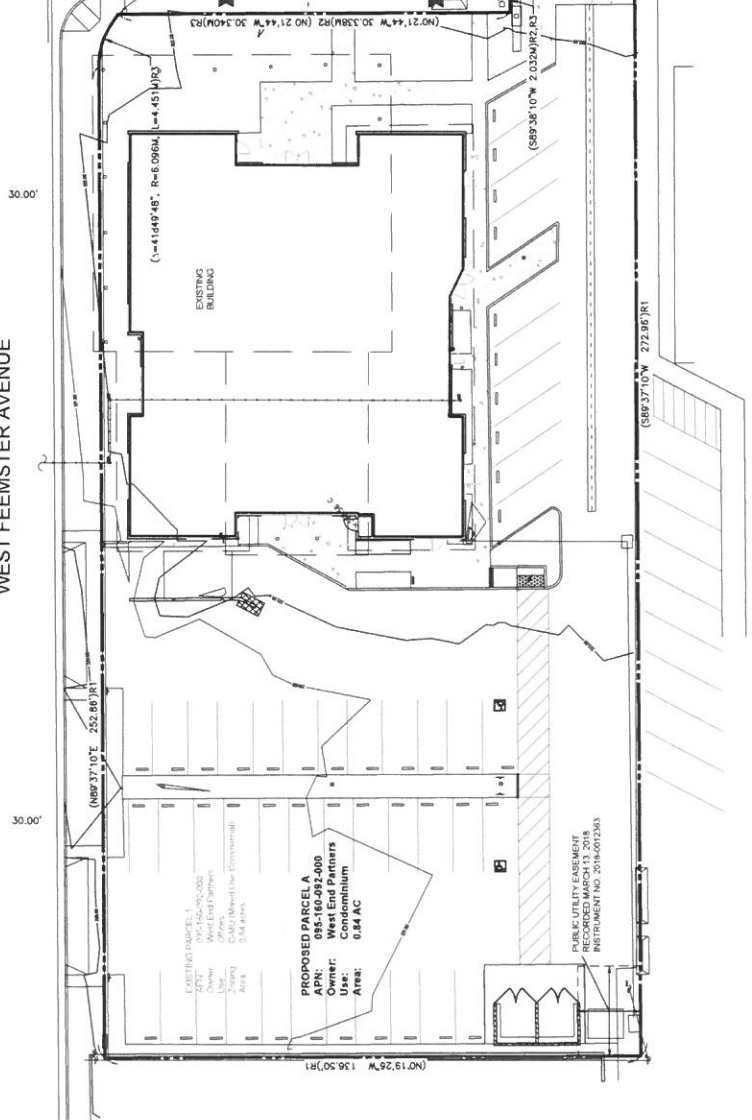

- NOTES:**
- There are buildings on the property.
  - The property is adjacent to the public right of way.
  - The property abuts the following public street:  
S. Mooney Blvd & W. Feemster Ave
  - The site address is formally known as  
1501 South Mooney Boulevard, Visalia, CA 93277
  - Zoning:  
Existing Landuse: C-MU (Mixed Use Commercial)  
Offices
  - The City of Visalia is the provider and source of water and sewerage. All City Utilities will be installed per City Standard.
  - The property privately maintains all onsite sewer, water, and storm drain lines.
- LEGEND**
- Limits of this subdivision
  - - - Building Canopy Line
  - (JR1) Record data per Title Report Legal Description Order No. 0724018173-H1
  - (JR2) Record data per Deed recorded March 1, 2007 as Instrument No. 2007-0020898 O.R.T.C.
  - (JR3) Record of Survey recorded as Document No. 2012-0011387, February 24, 2012, in Book 31 of Surveys, at Page 30.
  - ▲ Conveyed to the State of California in Deed recorded May 24, 1943 in Book 1033, Page 55, O.R.T.C.
  - ✕ Conveyed to the State of California in Deed recorded March 1, 2007 as Instrument No. 2007-0020898 O.R.T.C.

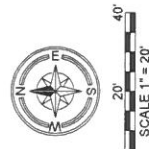

**BENCH-MARK:**

CITY OF VISALIA BENCHMARK NO. 31, P. 6 MARK IN TOP OF CURB, INTERSECTION OF SOUTH MOONEY BOULEVARD AND WALNUT AVENUE INTERSECTION.  
ELEVATION = 315.288' USGS NGS 03 DATUM

**FLOOD ZONE INFORMATION:**

This property lies in "Zone X" of "Other Flood Areas" as shown on Federal Emergency Management Agency (FEMA) Fresno County, California, and Incorporated Areas, Panel No. 529 of 2550, Map No. 06107C0529E (Map Revised: June 16, 2009).

Flood "Zone X" of "Other Flood Areas" is described as areas of 0.2% annual chance flood, areas of 1% annual chance flood with average depths of less than 1 foot or with drainage areas less than 1 square mile, and areas protected by levees from 1% annual chance flood.

**APPLICANT/SUBMITTER:**

West End Partners, LLC, a California limited liability company  
10 Harris Court, Suite B-1, Monterey, CA 93940

**LARS ANDERSEN & ASSOCIATES, INC.**  
CIVIL ENGINEERS - LAND SURVEYORS - PLANNERS  
4894 WEST JACQUELYN AVENUE FRESNO CALIFORNIA 93722  
TEL: 559 276-2790 FAX: 559 276-0850 WWW.LARSANDERSEN.COM  
JOB NO. 18130.00 DATE: DECEMBER 11, 2018 SHEET 1 OF 1

Exhibit "A"

**Recording Requested By:**

FIDELITY NATIONAL TITLE

**When Recorded Mail to**

REDWOOD GULCH, LLC  
10 Harris Court, Suite B-1  
Monterey, CA 93940  
Attn: Sherry Peverini

SPACE ABOVE THIS LINE FOR RECORDER'S USE

VISALIA COMMERCIAL CONDOMINIUM PLAN OF PARCEL 1, UNIT "A" & "B" OF  
PARCEL MAP FILED IN BOOK \_\_\_\_\_ AT PAGE \_\_\_\_\_ IN THE OFFICE OF  
THE TULARE COUNTY RECORDER, THE CITY OF VISALIA, STATE OF CALIFORNIA

SHEET INDEX

OWNER'S CERTIFICATE AND SIGNATURES.....	2-4
BENEFICIARY'S STATEMENT.....	5
DEFINITIONS.....	6
GENERAL NOTES.....	7
SURVEYOR'S STATEMENTS, BASIS OF BEARINGS AND BENCHMARKS.....	8
SITE PLAN.....	9
UNIT DETAIL.....	10



**LARS ANDERSEN & ASSOCIATES, INC.**

**CIVIL ENGINEERS - LAND SURVEYORS - PLANNERS**

4694 WEST JACQUELYN AVENUE      FRESNO CALIFORNIA 93722

TEL: 559 276-2790      FAX: 559 276-0850      WWW.LARSANDERSEN.COM

VISALIA COMMERCIAL CONDOMINIUM PLAN OF PARCEL 1, UNIT "A" & "B" OF  
PARCEL MAP FILED IN BOOK \_\_\_\_\_ AT PAGE \_\_\_\_\_ IN THE OFFICE OF  
THE TULARE COUNTY RECORDER, THE CITY OF VISALIA, STATE OF CALIFORNIA

OWNER'S CERTIFICATE:

WE, THE UNDERSIGNED BEING ALL OF THE RECORD OWNERS OF, THE REAL PROPERTY DESCRIBED IN THE DOCUMENTS HEREINAFTER MENTIONED, DO HEREBY VERIFY THAT:

WE, HEREBY CONSENT TO THE RECORDATION OF THIS PLAN OF CONDOMINIUM, PURSUANT TO SECTION 6624 OF THE CALIFORNIA CIVIL CODE, CONSISTING OF: (A) A DESCRIPTION OR SURVEY MAP OF A CONDOMINIUM PROJECT, WHICH REFERS TO OR SHOWS MONUMENTATION ON THE GROUND: (B) A THREE-DIMENSIONAL DESCRIPTION OF A CONDOMINIUM PROJECT, ONE OR MORE DIMENSIONS OF WHICH MAY EXTEND FOR AN INDEFINITE DISTANCE UPWARDS OR DOWNWARDS, IN SUFFICIENT DETAIL TO IDENTIFY THE COMMON AREA AND EACH SEPARATE INTEREST; AND (C) THIS CERTIFICATE.

REDWOOD GULCH, LLC, A CALIFORNIA LIMITED LIABILITY COMPANY

BY: \_\_\_\_\_  
PATRICK W. OROSCO, MEMBER

REDWOOD GULCH, LLC, A CALIFORNIA LIMITED LIABILITY COMPANY

BY: \_\_\_\_\_  
CHRISTOPHER R. OROSCO, MEMBER

VISALIA COMMERCIAL CONDOMINIUM PLAN OF PARCEL 1, UNIT "A" & "B" OF  
PARCEL MAP FILED IN BOOK \_\_\_\_\_ AT PAGE \_\_\_\_\_ IN THE OFFICE OF  
THE TULARE COUNTY RECORDER, THE CITY OF VISALIA, STATE OF CALIFORNIA

**NOTARY ACKNOWLEDGMENT:**

A notary public or other officer completing this certificate verifies only the identity of the individual who signed the document to which this certificate is attached, and not the truthfulness, accuracy, or validity of that document.

STATE OF CALIFORNIA

COUNTY OF \_\_\_\_\_

ON \_\_\_\_\_ BEFORE ME, \_\_\_\_\_ A NOTARY PUBLIC, PERSONALLY  
APPEARED \_\_\_\_\_, WHO PROVED TO ME ON THE BASIS OF SATISFACTORY  
EVIDENCE TO BE THE PERSON(S) WHOSE NAME(S) IS/ARE SUBSCRIBED TO THE WITHIN INSTRUMENT AND  
ACKNOWLEDGED TO ME THAT HE/SHE/THEY EXECUTED THE SAME IN HIS/HER/THEIR AUTHORIZED  
CAPACITY(IES), AND THAT BY HIS/HER/THEIR SIGNATURE(S) ON THE INSTRUMENT THE PERSON(S), OR ENTITY  
UPON BEHALF OF WHICH THE PERSON(S) ACTED, EXECUTED THE INSTRUMENT.

I CERTIFY UNDER PENALTY OF PERJURY UNDER THE LAWS OF THE STATE OF CALIFORNIA THAT THE  
FOREGOING PARAGRAPH IS TRUE AND CORRECT.

WITNESS MY HAND AND OFFICIAL SEAL:

SIGNATURE \_\_\_\_\_

VISALIA COMMERCIAL CONDOMINIUM PLAN OF PARCEL 1, UNIT "A" & "B" OF  
PARCEL MAP FILED IN BOOK \_\_\_\_\_ AT PAGE \_\_\_\_\_ IN THE OFFICE OF  
THE TULARE COUNTY RECORDER, THE CITY OF VISALIA, STATE OF CALIFORNIA

**NOTARY ACKNOWLEDGMENT:**

A notary public or other officer completing this certificate verifies only the identity of the individual who signed the document to which this certificate is attached, and not the truthfulness, accuracy, or validity of that document.

STATE OF CALIFORNIA

COUNTY OF \_\_\_\_\_

ON \_\_\_\_\_ BEFORE ME, \_\_\_\_\_ A NOTARY PUBLIC, PERSONALLY  
APPEARED \_\_\_\_\_, WHO PROVED TO ME ON THE BASIS OF SATISFACTORY  
EVIDENCE TO BE THE PERSON(S) WHOSE NAME(S) IS/ARE SUBSCRIBED TO THE WITHIN INSTRUMENT AND  
ACKNOWLEDGED TO ME THAT HE/SHE/THEY EXECUTED THE SAME IN HIS/HER/THEIR AUTHORIZED  
CAPACITY(IES), AND THAT BY HIS/HER/THEIR SIGNATURE(S) ON THE INSTRUMENT THE PERSON(S), OR ENTITY  
UPON BEHALF OF WHICH THE PERSON(S) ACTED, EXECUTED THE INSTRUMENT.

I CERTIFY UNDER PENALTY OF PERJURY UNDER THE LAWS OF THE STATE OF CALIFORNIA THAT THE  
FOREGOING PARAGRAPH IS TRUE AND CORRECT.

WITNESS MY HAND AND OFFICIAL SEAL:

SIGNATURE \_\_\_\_\_

VISALIA COMMERCIAL CONDOMINIUM PLAN OF PARCEL 1, UNIT "A" & "B" OF  
PARCEL MAP FILED IN BOOK \_\_\_\_\_ AT PAGE \_\_\_\_\_ IN THE OFFICE OF  
THE TULARE COUNTY RECORDER, THE CITY OF VISALIA, STATE OF CALIFORNIA

**BENEFICIARY'S STATEMENT:**

SUNCREST BANK, A NATIONAL BANKING ASSOCIATION AS BENEFICIARY UNDER DEED OF TRUST, RECORDED  
AUGUST 30, 2018 AS DOCUMENT NO. 2018-0047747, OFFICIAL RECORDS OF TULARE COUNTY,  
ENCUMBERING THE LAND HEREIN SHOWN, HEREBY CONSENTS TO THE MAKING AND FILING OF THIS PLAN.

BY: \_\_\_\_\_

NAME: \_\_\_\_\_

TITLE: \_\_\_\_\_

**NOTARY ACKNOWLEDGMENT:**

A notary public or other officer completing this certificate verifies only the identity of the individual who signed the document to which this certificate is attached, and not the truthfulness, accuracy, or validity of that document.

STATE OF CALIFORNIA

COUNTY OF \_\_\_\_\_

ON \_\_\_\_\_ BEFORE ME, \_\_\_\_\_ A NOTARY PUBLIC, PERSONALLY  
APPEARED \_\_\_\_\_, WHO PROVED TO ME ON THE BASIS OF SATISFACTORY  
EVIDENCE TO BE THE PERSON(S) WHOSE NAME(S) IS/ARE SUBSCRIBED TO THE WITHIN INSTRUMENT AND  
ACKNOWLEDGED TO ME THAT HE/SHE/THEY EXECUTED THE SAME IN HIS/HER/THEIR AUTHORIZED  
CAPACITY(IES), AND THAT BY HIS/HER/THEIR SIGNATURE(S) ON THE INSTRUMENT THE PERSON(S), OR ENTITY  
UPON BEHALF OF WHICH THE PERSON(S) ACTED, EXECUTED THE INSTRUMENT.

I CERTIFY UNDER PENALTY OF PERJURY UNDER THE LAWS OF THE STATE OF CALIFORNIA THAT THE  
FOREGOING PARAGRAPH IS TRUE AND CORRECT.

WITNESS MY HAND AND OFFICIAL SEAL:

SIGNATURE \_\_\_\_\_

VISALIA COMMERCIAL CONDOMINIUM PLAN OF PARCEL 1, UNIT "A" & "B" OF  
PARCEL MAP FILED IN BOOK \_\_\_\_\_ AT PAGE \_\_\_\_\_ IN THE OFFICE OF  
THE TULARE COUNTY RECORDER, THE CITY OF VISALIA, STATE OF CALIFORNIA

DEFINITIONS:

1. THIS CONDOMINIUM PLAN IS INTENDED TO SATISFY THE REQUIREMENTS OF CALIFORNIA CIVIL CODE SECTION 6624 WHICH REQUIRES (A) A DESCRIPTION OR SURVEY MAP OF A CONDOMINIUM PROJECT, WHICH SHALL REFER TO OR SHOW MONUMENTATION ON THE GROUND; (B) A THREE DIMENSIONAL DESCRIPTION OF A CONDOMINIUM PROJECT IN SUFFICIENT DETAIL TO IDENTIFY THE COMMON AREA AND EACH SEPARATE INTEREST; AND (C) A CERTIFICATE CONSENTING TO THE RECORDATION OF THE CONDOMINIUM PLAN PURSUANT TO THIS ACT THAT IS SIGNED AND ACKNOWLEDGED AS PROVIDED IN CALIFORNIA CIVIL CODE SECTION 6626. ALL DIMENSIONS HEREIN ARE TO BE CONSIDERED TO BE APPROXIMATE AND ARE NOT SUFFICIENTLY ACCURATE TO BE USED FOR COMPUTATION OF FLOOR AREA OR AIRSPACE VOLUME AND MAY DIFFER FROM AS-BUILT CONDITIONS.

THE LEGAL DESCRIPTION OF THIS CONDOMINIUM PROJECT IS PARCEL 1 OF PARCEL MAP FILED IN BOOK \_\_\_\_\_ AT PAGE \_\_\_\_\_ IN THE CITY OF VISALIA, COUNTY OF TULARE, STATE OF CALIFORNIA

2. EACH CONDOMINIUM UNIT IS DESIGNATED HEREIN BY A LETTER "A" AND "B" (2 TOTAL UNITS).  
UNIT "A" IS THE RETAIL "A" UNIT.  
UNIT "B" IS THE RETAIL "B" UNIT.
3. THIS CONDOMINIUM PLAN INTENTIONALLY OMITTS DETAILED INFORMATION OF INTERNAL PARTITIONING WITHIN INDIVIDUAL UNITS. LIKEWISE, SUCH FEATURES SUCH AS FURRED, SLOPED, DOMED, RAISED, LOWERED OR IRREGULAR CEILINGS, TRUSSES, SOFFITS, SKYLIGHTS, ELEVATOR EQUIPMENT AND SHAFTS, AIRSPACE SHAFTS AND PIPES, DUCTS, FLUES, CHUTES, CONDUITS, WIRES, PROTRUSIONS OF VENTS, BEAMS, COLUMNS, DOOR AND WINDOW CASINGS AND BAY WINDOWS, HEATING AND AIR CONDITIONING AND OTHER MECHANICAL FACILITIES AND EQUIPMENT, UTILITY INSTALLATIONS, OUTLETS AND OTHER SUCH FEATURES, ARE NOT INTENDED TO BE REFLECTED ON THIS PLAN.
4. ALL TIES TO PROPERTY LINES SHOWN HEREIN ARE MEASURED FROM UNIT BOUNDARIES AND UNLESS OTHERWISE INDICATED, ARE AT A RIGHT ANGLE TO THE SAID UNIT.
5. UNLESS OTHERWISE INDICATED, ALL AIRSPACE BOUNDARY LINES INTERSECT AT A RIGHT ANGLE.
6. ALL DIMENSIONS SHOWN HEREIN ARE IN FEET.
7. THE LOWER VERTICAL LIMIT ELEVATIONS (L.V.L.E.) AND UPPER VERTICAL LIMIT ELEVATION (U.V.L.E.) FOR THE FOLLOWING AIRSPACE, BASED ON THE BENCHMARK ELEVATION NOTED HEREIN, IS AS FOLLOWS:

AIRSPACE	L.V.L.E.	U.V.L.E.
UNIT "A"	323.13' (feet)	351.63' (feet)
UNIT "B"	323.13' (feet)	349.63' (feet)

8. FOR THE DEFINITIONS OF "COMMON AREA", "CONDOMINIUM", "EXCLUSIVE USE OF COMMON AREA", AND "UNIT", SEE THE DECLARATION OF RESTRICTIONS FOR 1501 SOUTH MOONEY COMMERCIAL CONDOMINIUMS (THE "DECLARATION"). IF THERE IS A CONFLICT BETWEEN THIS CONDOMINIUM PLAN AND THE DECLARATION FOR THIS CONDOMINIUM PROJECT, THE DECLARATION SHALL PREVAIL.

VISALIA COMMERCIAL CONDOMINIUM PLAN OF PARCEL 1, UNIT "A" & "B" OF  
PARCEL MAP FILED IN BOOK \_\_\_\_\_ AT PAGE \_\_\_\_\_ IN THE OFFICE OF  
THE TULARE COUNTY RECORDER, THE CITY OF VISALIA, STATE OF CALIFORNIA

**GENERAL NOTES:**

**CONFLICTS.** TERMS NOT DEFINED HEREIN SHALL HAVE THE MEANINGS SET FORTH IN THE DECLARATION.

**CONDOMINIUM PLAN FOR DIAGRAMMATIC PURPOSES ONLY.** THIS CONDOMINIUM PLAN (AND THE DIMENSIONS SHOWN HEREIN) IS INTENDED TO CONFORM TO CALIFORNIA CIVIL CODE SECTION 6624, WHICH REQUIRES IN PART, CONCERNING THE LAND AND REAL PROPERTY DESCRIBED THEREIN, THE INCLUSION OF DIAGRAMMATIC PLANS IN SUFFICIENT DETAIL TO IDENTIFY THE COMMON AREA AND EACH UNIT, ITS RELATIVE LOCATION AND APPROXIMATE DIMENSIONS. THE DIMENSIONS SHOWN IN THIS CONDOMINIUM PLAN ARE NOT INTENDED TO BE SUFFICIENTLY ACCURATE TO USE FOR SALES PURPOSES, OR FOR COMPUTATION OF USABLE FLOOR AREA OR THE VOLUME OF ANY PORTION OF THE UNITS SHOWN IN THIS CONDOMINIUM PLAN. THE DIAGRAMMATIC PLANS CONTAINED HEREIN INTENTIONALLY OMIT INFORMATION WITH RESPECT TO CERTAIN IMPROVEMENTS CONSTRUCTED WITHIN THE UNITS. THE ACTUAL LOCATIONS AND DIMENSIONS OF A PARTICULAR ROOM, UNIT OR COMMON AREA ARE ALL DEPENDENT ON THE IMPROVEMENTS AS THEY WERE ACTUALLY CONSTRUCTED, AND THERE MAY BE VARIANCES DUE TO FIELD CONDITIONS AND THE PRESENCE OF INTERIOR IMPROVEMENTS THAT ARE NOT SHOWN IN THIS CONDOMINIUM PLAN. THIS COMDOMINIUM PLAN IS NOT A REPRESENTATION OR WARRANTY AS TO THE ACTUAL LOCATIONS OR DIMENSIONS OF THE UNIT OR COMMON AREA SHOWN HEREIN. IN ALL INSTANCES, THE ACTUAL LOCATIONS AND DIMENSIONS OF THE IMPROVEMENTS AS CONSTRUCTED WILL CONTROL OVER THE LOCATIONS OR DIMENSIONS DISCLOSED IN THIS CONDOMINIUM PLAN. THE ONLY RELIABLE DETERMINATION OF THE USABLE FLOOR AREA OR VOLUME OF A UNIT OR COMMON AREA IS A DETERMINATION MADE FROM ON-SITE MEASUREMENTS OF THE IMPROVEMENTS AS THEY ARE CONSTRUCTED.



VISALIA COMMERCIAL CONDOMINIUM PLAN OF PARCEL 1, UNIT "A" & "B" OF  
PARCEL MAP FILED IN BOOK \_\_\_\_\_ AT PAGE \_\_\_\_\_ IN THE OFFICE OF  
THE TULARE COUNTY RECORDER, THE CITY OF VISALIA, STATE OF CALIFORNIA

SURVEYOR'S STATEMENT:

I HEREBY STATE THAT I AM A LICENSED LAND SURVEYOR OF THE STATE OF CALIFORNIA AND THAT THIS PLAN CONSISTING OF 10 SHEETS CORRECTLY SHOWS THE BOUNDARY OF PARCEL 1 FILED IN BOOK \_\_\_\_\_ AT PAGE \_\_\_\_\_ IN THE OFFICE OF TULARE COUNTY RECORDER AND THE RELATION THERETO OF THE PROPOSED 2 UNITS SHOWN HEREIN. THE AIRSPACE OWNERSHIP SHOWN HEREIN IS BASED UPON THE ARCHITECTURAL PLANS BY VERMELTFOORT ARCHITECTS INCORPORATED MEASUREMENTS AND NO STRUCTURAL OR NON-STRUCTURAL FEATURES WERE CONSIDERED WHEN THE ARCHITECT'S PLANS WERE REVIEWED FOR LOCATION OF UNITS OF AIRSPACE.

\_\_\_\_\_  
Daniel J. Zoldak, PLS 9279  
DATE PREPARED: 12/11/2018



BENCHMARK:

CITY OF VISALIA BENCHMARK NO. 31. P-K NAIL IN TOP OF CURB, EAST RADIUS POINT, SOUTHEAST CORNER OF MOONEY BOULEVARD AND WALNUT AVENUE INTERSECTION.  
ELEVATION = 319.288' USGS NGVD 29 DATUM

BASIS OF BEARING:

THE EAST LINE OF THE SOUTHEAST QUARTER OF SECTION 36,  $\frac{18}{24}$ , MOUNT DIABLO BASE AND MERIDIAN PER RECORD OF SURVEY FILED IN BOOK 31 AT PAGE 30, TULARE COUNTY RECORDS. TAKE TO BE N 00°21'50" W.

VISALIA COMMERCIAL CONDOMINIUM PLAN OF PARCEL 1, UNIT "A" & "B" OF  
 PARCEL MAP FILED IN BOOK \_\_\_\_\_ AT PAGE \_\_\_\_\_ IN THE OFFICE OF  
 THE TULARE COUNTY RECORDER, THE CITY OF VISALIA, STATE OF CALIFORNIA

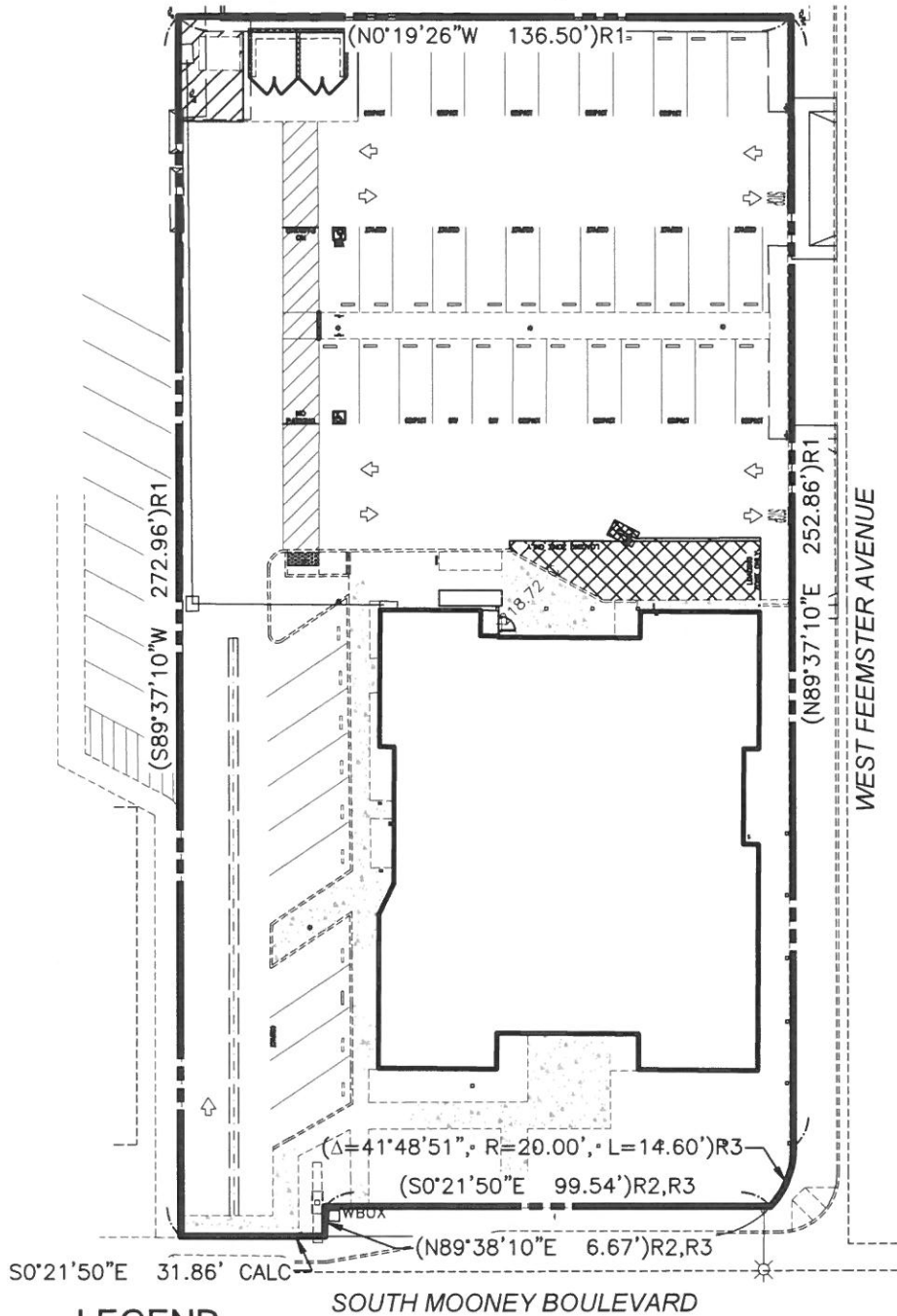

**LEGEND**

- Project Boundary Line
- ( )R1 Record data per Title Report Legal Description Order No. 0724018173-HT
- ( )R2 Record data per Deed recorded March 1, 2007 as Instrument No. 2007-0020898 O.R.T.C.
- ( )R3 Record of Survey recorded as Document No. 2012-0011387, February 24, 2012, in Book 31 of Surveys, at Page 30.
- E.U.C.A. Exclusive Use Common Area



**LARS ANDERSEN & ASSOCIATES, INC.**  
 CIVIL ENGINEERS - LAND SURVEYORS - PLANNERS  
 4694 WEST JACQUELYN AVENUE FRESNO CALIFORNIA 93722  
 TEL: 559 276-2790 FAX: 559 276-0850 WWW.LARSANDERSEN.COM

CONDOMINIUM PLAN  
 FOR  
 REDWOOD GULCH, LLC  
 10 HARRIS COURT, SUITE B-1  
 MONTEREY, CA 93940

SCALE: 1" = 40'  
 DATE: DECEMBER 11, 2018  
 SHEET 9 OF 10

VISALIA COMMERCIAL CONDOMINIUM PLAN OF PARCEL 1, UNIT "A" & "B" OF  
 PARCEL MAP FILED IN BOOK \_\_\_\_\_ AT PAGE \_\_\_\_\_ IN THE OFFICE OF  
 THE TULARE COUNTY RECORDER, THE CITY OF VISALIA, STATE OF CALIFORNIA

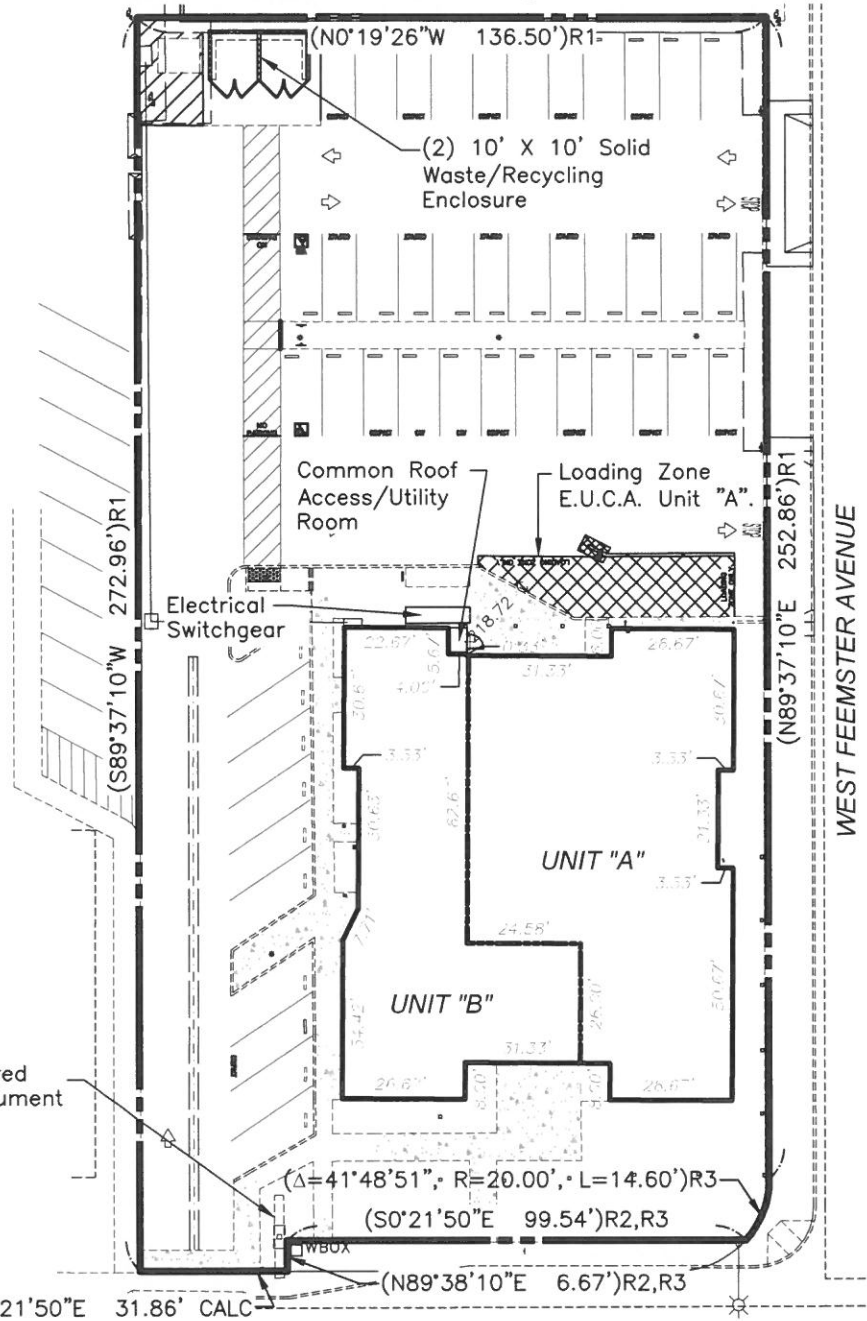

**NOTES**

1. All of Parcel 1 is common area, except for units.
2. Pursuant to the Declaration of Covenants, Conditions, and Restrictions all units are measured from the exterior walls to the center of the demising walls.

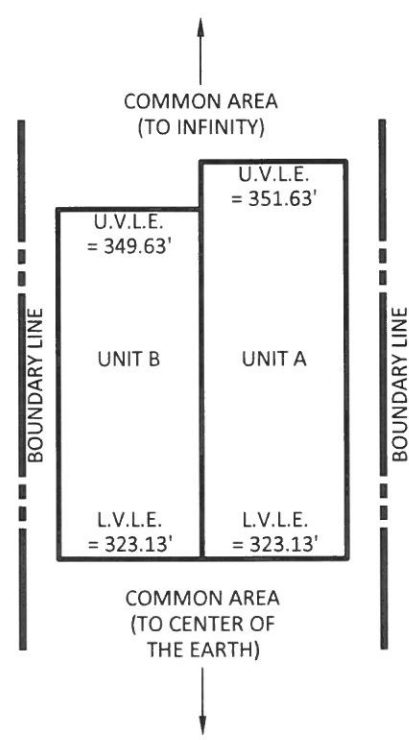

**LEGEND**

- Unit Boundary Line
- - - Project Boundary Line
- ( )R1 Record data per Title Report Legal Description Order No. 0724018173-HT
- ( )R2 Record data per Deed recorded March 1, 2007 as Instrument No. 2007-0020898 O.R.T.C.
- ( )R3 Record of Survey recorded as Document No. 2012-0011387, February 24, 2012, in Book 31 of Surveys, at Page 30.
- E.U.C.A. Exclusive Use Common Area

SOUTH MOONEY BOULEVARD



**LARS ANDERSEN & ASSOCIATES, INC.**  
 CIVIL ENGINEERS - LAND SURVEYORS - PLANNERS  
 4694 WEST JACQUELYN AVENUE FRESNO CALIFORNIA 93722  
 TEL: 559 276-2790 FAX: 559 276-0850 WWW.LARSANDERSEN.COM

CONDOMINIUM PLAN  
 FOR  
 REDWOOD GULCH, LLC  
 10 HARRIS COURT, SUITE B-1  
 MONTEREY, CA 93940

SCALE: 1" = 40'  
 DATE: DECEMBER 11, 2018  
 SHEET 10 OF 10

SET ISSUED:  
SITE PLAN REVIEW  
2018-07-31

OWNER:  
WEST END  
PARTNERS, LLC  
10 HARRIS COURT,  
SUITE B-1  
MONTEREY, CA  
TEL: (831) 649-0220

PROJECT:  
1501 S MOONEY COMMERCIAL CONDOMINIUM  
1501 S MOONEY BLVD.  
VISALIA, CA 93277  
APN: 095-160-092

DATE:  
JULY 31, 2018  
SHEET NAME:  
OVERALL  
SITE PLAN

SHEET NO.:  
**A100**

W. Feemster Ave.

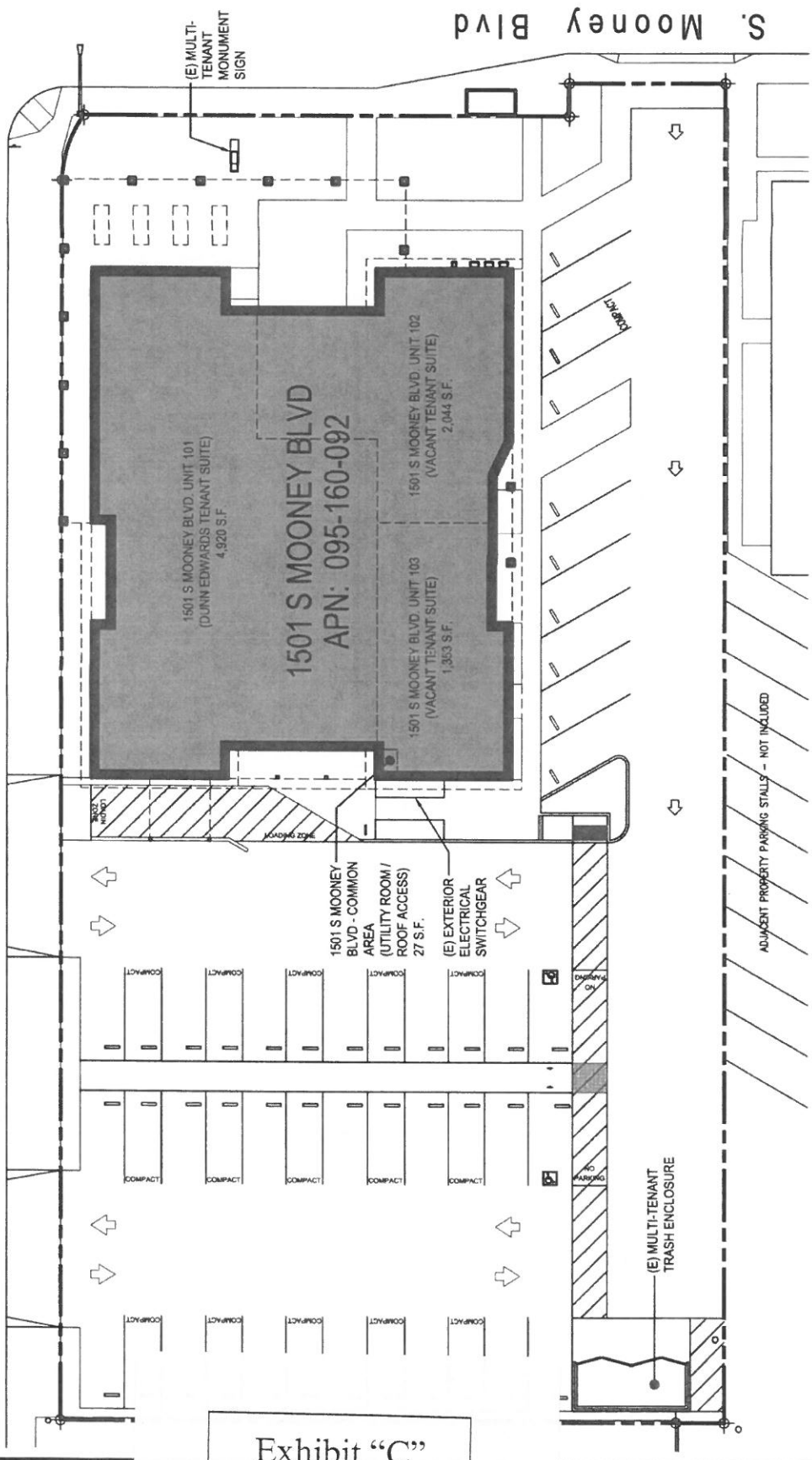

NOTE: NO MODIFICATIONS TO THE EXISTING SITE OR BUILDING PROPOSED ASSOCIATED TO THE PROPOSED COMMERCIAL CONDOMINIUM.

EXISTING OVERALL SITE PLAN  
SCALE: 1" = 20'-0"



1

Exhibit "C"

SET ISSUED:  
SITE PLAN REVIEW  
2018-07-31

OWNER:  
WEST END  
PARTNERS, LLC  
10 HARRIS COURT,  
SUITE B-1  
MONTEREY, CA  
TEL: (831) 649-0220

PROJECT:  
1501 S MOONEY COMMERCIAL CONDOMINIUM  
1501 S MOONEY BLVD.  
VISALIA, CA 93277  
APN: 095-160-092

DATE:  
JULY 31, 2018  
SHEET NAME:  
PROPOSED  
COMMERCIAL  
CONDO PLAN

SHEET NO.:  
**A101**

W. Feemster Ave.

S. Mooney Blvd

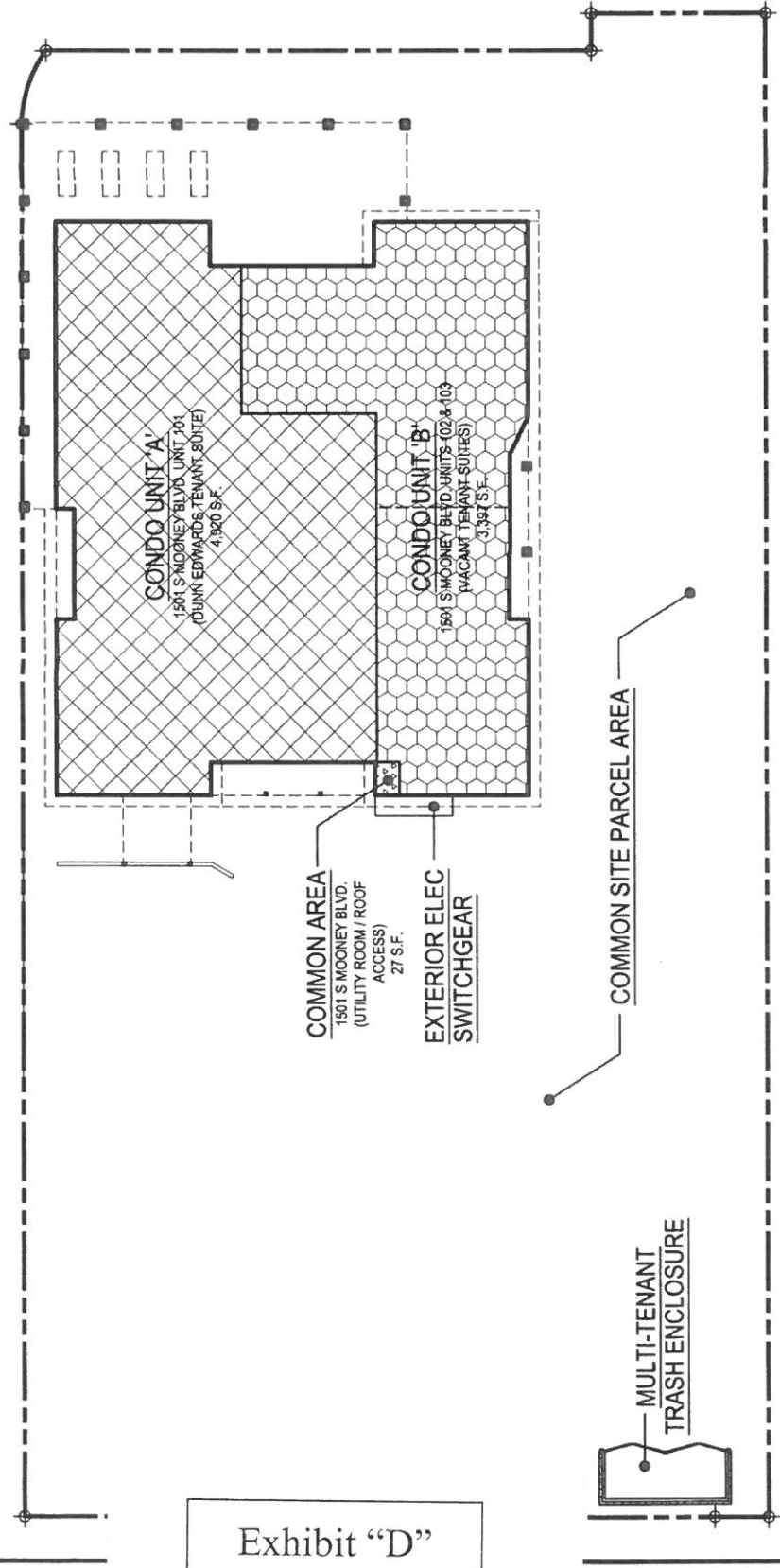

**CONDO UNIT 'A'**  
1501 S MOONEY BLVD. UNIT 201  
(DUNKI EDWARDS TENANT SUITE)  
4,920 S.F.

**CONDO UNIT 'B'**  
1501 S MOONEY BLVD. UNITS - 02 & 109  
(VACANT TENANT SUITES)  
3,397 S.F.

**COMMON AREA**  
1501 S MOONEY BLVD.  
(UTILITY ROOM / ROOF  
ACCESS)  
27 S.F.

**EXTERIOR ELEC  
SWITCHGEAR**

**COMMON SITE PARCEL AREA**

**MULTI-TENANT  
TRASH ENCLOSURE**

Exhibit "D"

**PROPOSED COMMERCIAL CONDOMINIUM PLAN**  
SCALE: 1" = 20'-0"

NOTE: NO MODIFICATIONS TO THE EXISTING SITE OR BUILDING PROPOSED ASSOCIATED TO THE PROPOSED COMMERCIAL CONDOMINIUM.

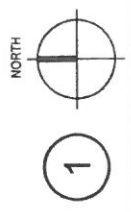

SET ISSUED:  
SITE PLAN REVIEW  
2018-07-31

OWNER:  
WEST END  
PARTNERS, LLC  
10 HARRIS COURT,  
SUITE B-1  
MONTEREY, CA  
TEL: (831) 649-0220

PROJECT:  
1501 S MOONEY COMMERCIAL CONDOMINIUM  
1501 S MOONEY BLVD.  
VISALIA, CA 93277  
APN: 095-160-092

DATE:  
JULY 31, 2018

SHEET NAME:  
EXISTING FLOOR  
PLAN

SHEET NO.:  
**A200**

W. Feemster Ave.

S. Mooney Blvd

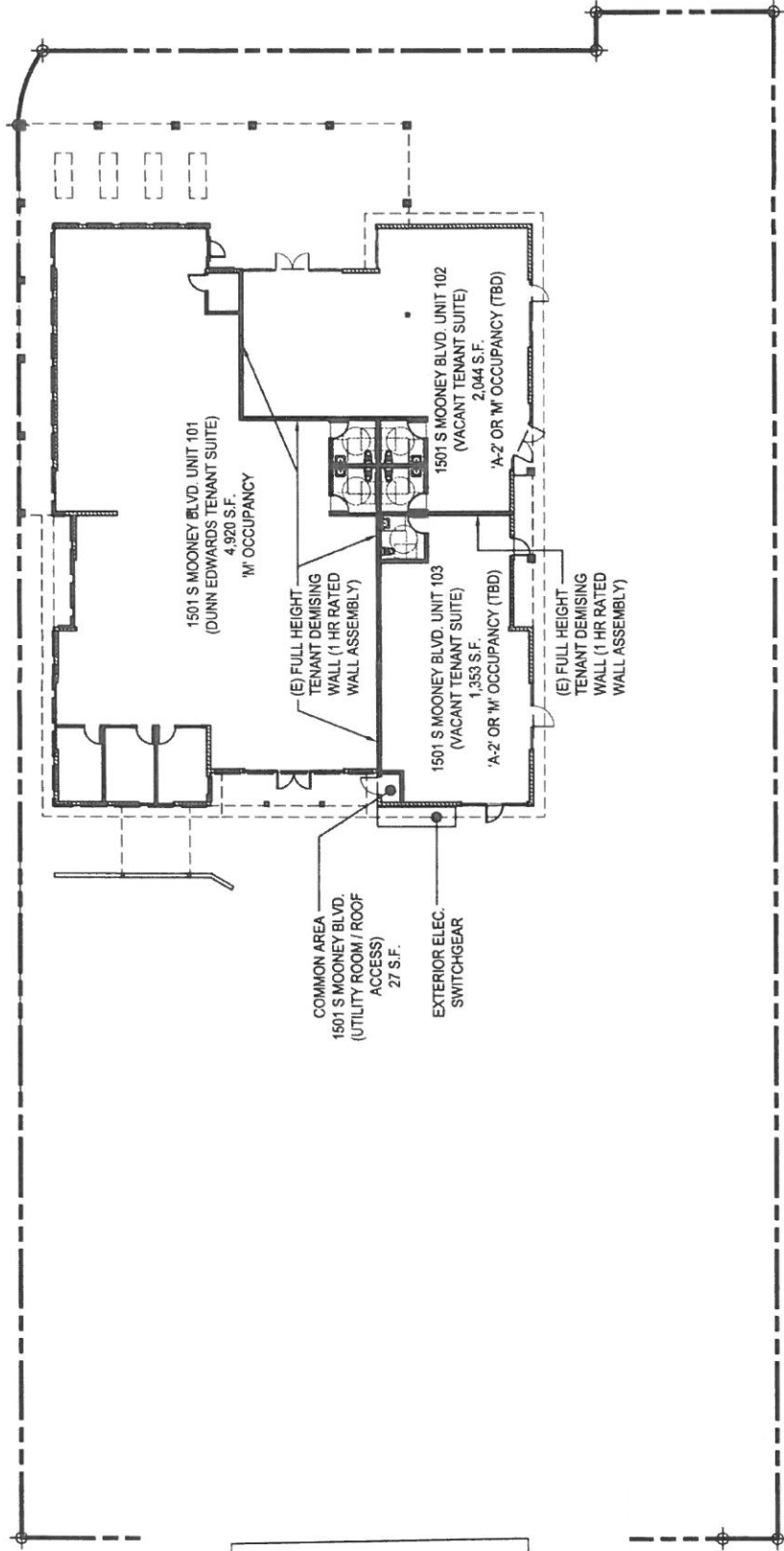

NOTE: NO MODIFICATIONS TO THE EXISTING SITE OR BUILDING PROPOSED  
ASSOCIATED TO THE PROPOSED COMMERCIAL CONDOMINIUM.

**EXISTING FLOOR PLAN (FOR REFERENCE ONLY)**  
SCALE: 1" = 20'-0"



1

Exhibit "E"



# 7

MEETING DATE: August 8, 2018

SITE PLAN NO. 18-140

PARCEL MAP NO.

SUBDIVISION:

LOT LINE ADJUSTMENT NO.

Enclosed for your review are the comments and decisions of the Site Plan Review committee. Please review all comments since they may impact your project.

**RESUBMIT** Major changes to your plans are required. Prior to accepting construction drawings for building permit, your project must return to the Site Plan Review Committee for review of the revised plans.

During site plan design/policy concerns were identified, schedule a meeting with  
 Planning  Engineering prior to resubmittal plans for Site Plan Review.

Solid Waste  Parks and Recreation  Fire Dept.

**REVISE AND PROCEED** (see below)

A revised plan addressing the Committee comments and revisions must be submitted for Off-Agenda Review and approval prior to submitting for building permits or discretionary actions.

Submit plans for a building permit between the hours of 9:00 a.m. and 4:00 p.m., Monday through Friday.

Your plans must be reviewed by:

CITY COUNCIL

REDEVELOPMENT

PLANNING COMMISSION

PARK/RECREATION

CONDO MAP/TPM

HISTORIC PRESERVATION

OTHER: \_\_\_\_\_

**ADDITIONAL COMMENTS :**

If you have any questions or comments, please call Jason Huckleberry at (559) 713-4259.

*Site Plan Review Committee*



**SUBDIVISION & PARCEL MAP  
REQUIREMENTS  
ENGINEERING DIVISION**

- Jason Huckleberry 713-4259
- Adrian Rubalcaba 713-4271
- Diego Corvera 713-4209

ITEM NO: 7 DATE: AUGUST 8, 2018

SITE PLAN NO.: 18-140  
PROJECT TITLE: 1501 S MOONEY COMMERCIAL RETAIL BUILDING  
DESCRIPTION: PROPOSED COMMERCIAL CONDOMINIUM, ESTABLISH 2 COMMERCIAL CONDOMINIUMS W/ COMMON SIZE PARCEL  
APPLICANT: MATT NOHR  
PROP. OWNER: WEST END PARTNERS LLC  
LOCATION: 1501 S MOONEY BLVD  
APN: 095-160-092

**SITE PLAN REVIEW COMMENTS**

- REQUIREMENTS (Indicated by checked boxes)
- Submit improvements plans detailing all proposed work;  Subdivision Agreement will detail fees & bonding requirements
- Bonds, certificate of insurance, cash payment of fees/inspection, and approved map & plan required prior to approval of Final Map.
- The Final Map & Improvements shall conform to the Subdivision Map Act, the City's Subdivision Ordinance and Standard Improvements.
- A preconstruction conference is required prior to the start of any construction.
- Right-of-way dedication required. A title report is required for verification of ownership.  by map  by deed
- City Encroachment Permit Required which shall include an approved traffic control plan.
- CalTrans Encroachment Permit Required.  CalTrans comments required prior to tentative parcel map approval. CalTrans contacts: David Deel (Planning) 488-4088
- Landscape & Lighting District/Home Owners Association required prior to approval of Final Map. Landscape & Lighting District will maintain common area landscaping, street lights, street trees and local streets as applicable. Submit completed Landscape and Lighting District application and filing fee a min. of 75 days before approval of Final Map. **COMMERCIAL TO MAINTAIN ALL SITE LANDSCAPING**
- Landscape & irrigation improvement plans to be submitted for each phase. Landscape plans will need to comply with the City's street tree ordinance. The locations of street trees near intersections will need to comply with Plate SD-1 of the City improvement standards. A street tree and landscape master plan for all phases of the subdivision will need to be submitted with the initial phase to assist City staff in the formation of the landscape and lighting assessment district.
- Dedicate landscape lots to the City that are to be maintained by the Landscape & Lighting District.
- Northeast Specific Plan Area: Application for annexation into Northeast District required 75 days prior to Final Map approval.
- Written comments required from ditch company. Contacts: James Silva 747-1177 for Modoc, Persian, Watson, Oakes, Flemming, Evans Ditch and Peoples Ditches; Paul Hendrix 686-3425 for Tulare Irrigation Canal, Packwood and Cameron Creeks; Bruce George 747-5601 for Mill Creek and St. John's River.
- Final Map & Improvements shall conform to the City's Waterways Policy.  Access required on ditch bank, 12' minimum.  Provide wide riparian dedication from top of bank.
- Sanitary Sewer master plan for the entire development shall be submitted for approval prior to approval of any portion of the system. The sewer system will need to be extended to the boundaries of the development where future connection and extension is anticipated. The sewer system will need to be sized to serve any future developments that are anticipated to connect to the system.
- Grading & Drainage plan required. If the project is phased, then a master plan is required for the entire project area that shall include pipe network sizing and grades and street grades.  Prepared by registered civil engineer or project architect.  All elevations shall be based on the City's benchmark network. Storm run-off from the project shall be handled as follows: a)  directed to the City's existing storm drainage system; b)  directed to a permanent on-site basin; or c)  directed to a temporary on-site basin is



required until a connection with adequate capacity is available to the City's storm drainage system. On-site basin: : maximum side slopes, perimeter fencing required, provide access ramp to bottom for maintenance.

- Show Valley Oak trees with drip lines and adjacent grade elevations.  Protect Valley Oak trees during construction in accordance with City requirements.  A permit is required to remove Valley Oak trees. Contact Public Works Admin at (559)713-4428 for a Valley Oak tree evaluation or permit to remove.  Valley Oak tree evaluations by a certified arborist are required to be submitted to the City in conjunction with the tentative map application.  A pre-construction conference is required.
- Show adjacent property grade elevations on improvement plans. A retaining wall will be required for grade differences greater than 0.5 feet at the property line.
- Relocate existing utility poles and/or facilities.
- Underground all existing overhead utilities within the project limits. Existing overhead electrical lines over 50kV shall be exempt from undergrounding.
- Provide "R" value tests: each at
- Traffic indexes per city standards:
- All public streets within the project limits and across the project frontage shall be improved to their full width, subject to available right of way, in accordance with City policies, standards and specifications.
- All lots shall have separate drive approaches constructed to City Standards.
- Install street striping as required by the City Engineer.
- Install sidewalk: ft. wide, with ft. wide parkway on
- Cluster mailbox supports required at 1 per 2 lots, or use postal unit (contact the Postmaster at 732-8073).
- Subject to existing Reimbursement Agreement to reimburse prior developer:
- Abandon existing wells per City of Visalia Code. A building permit is required.
- Remove existing irrigation lines & dispose off-site.  Remove existing leach fields and septic tanks.
- Fugitive dust will be controlled in accordance with the applicable rules of San Joaquin Valley Air District's Regulation VIII. Copies of any required permits will be provided to the City.
- If the project requires discretionary approval from the City, it may be subject to the San Joaquin Valley Air District's Rule 9510 Indirect Source Review per the rule's applicability criteria. A copy of the approved AIA application will be provided to the City.
- If the project meets the one acre of disturbance criteria of the State's Storm Water Program, then coverage under General Permit Order 2009-0009-DWQ is required and a Storm Water Pollution Prevention Plan (SWPPP) is needed. A copy of the approved permit and the SWPPP will be provided to the City.
- Comply with prior comments  Resubmit with additional information  Redesign required

**Additional Comments:**

- 1. Proposed maps to provide common access and maintenance of improvements.***
- 2. Refer to City processing and filing fees for maps.***

**SUMMARY OF APPLICABLE DEVELOPMENT IMPACT FEES**

Site Plan No: **18-140**  
Date: **8/18/2018**

**Summary of applicable Development Impact Fees to be collected at the time of final/parcel map recordation:**

**(Preliminary estimate only! Final fees will be based on approved subdivision map & improvements plans and the fee schedule in effect at the time of recordation.)**

(Fee Schedule Date:**7/1/2018**)  
(Project type for fee rates:**TENTATIVE PARCEL & CONDO MAP**)

Existing uses may qualify for credits on Development Impact Fees.

<b>FEE ITEM</b>	<b>FEE RATE</b>
<input type="checkbox"/> Trunk Line Capacity Fee	
<input type="checkbox"/> Sewer Front Foot Fee	
<input type="checkbox"/> Storm Drainage Acquisition Fee	
<input type="checkbox"/> Park Acquisition Fee	
<input type="checkbox"/> Northeast Acquisition Fee Total Storm Drainage Block Walls Parkway Landscaping Bike Paths	
<input type="checkbox"/> Waterways Acquisition Fee	

**Additional Development Impact Fees will be collected at the time of issuance of building permits.**

**City Reimbursement:**

- 1.) No reimbursement shall be made except as provided in a written reimbursement agreement between the City and the developer entered into prior to commencement of construction of the subject planned facilities.
- 2.) Reimbursement is available for the development of arterial/collector streets as shown in the City's Circulation Element and funded in the City's transportation impact fee program. The developer will be reimbursed for construction costs and right of way dedications as outlined in Municipal Code Section 16.44. Reimbursement unit costs will be subject to those unit costs utilized as the basis for the transportation impact fee.
- 3.) Reimbursement is available for the construction of storm drain trunk lines and sanitary sewer trunk lines shown in the City's Storm Water Master Plan and Sanitary Sewer System Master Plan. The developer will be reimbursed for construction costs associated with the installation of these trunk lines.



**Adrian Rubalcaba**

# SITE PLAN REVIEW COMMENTS

Andrew Chamberlain, Planning Division (559) 713-4003

Date: August 8, 2018

SITE PLAN NO: 2018-140  
PROJECT TITLE: Commercial Condominium Map / Parcel Map  
DESCRIPTION: Commercial Condominium Map (CR)  
APPLICANT: Matt Nohr  
PROP. OWNER: West End Partners  
LOCATION TITLE: 1501 S. Mooney  
APN TITLE: 095-160-092  
GENERAL PLAN: Mixed Use Commercial  
EXISTING ZONING: C-MU – Mixed Use Commercial



## **Planning Division Recommendation:**

- Revise and Proceed – Parcel Map w/Condo map process
- Off-Agenda – provide detailed site plan of development pattern
- Resubmit

## **Project Requirements**

- Parcel Map process
- Condominium Map Plan to be included as part of the PM process
- Conditional Use Permit required for the creation of parcels without public street frontage
- Additional Information as Needed

## **PROJECT SPECIFIC INFORMATION:**

1. A Parcel Map process is required. Application materials to include the Condominium plan and details for mapping purposes. Parcel Map needs to meet map face standards, cannot be processed as a Site Plan.
2. A Conditional Use Permit is required for the creation of parcels without public street frontage.
3. Project will be conditioned to provide an association or similar process for parking, solid waste, maintenance and related common ownership actions.
4. The PM action will be conditioned to maintain the overall project area in a uniform manner.
5. Meet all other site development conditions for the existing development.
6. Meet all other codes and ordinances.

Staff initial finding is that the proposed site plan IS CONSISTENT with the City General Plan. Because this project requires discretionary approval (FOC) by the City Council and/or Planning Commission the final determination of consistency will be made by the Planning Commission and/or City Council.

**NOTE: Staff recommendations contained in this document are not to be considered support for a particular action or project unless otherwise stated in the comments. The comments found on this document pertain to the site plan submitted for review on the above referenced date. Any changes made to the plan submitted must be submitted for additional review.**

Signature

SFR 18140  
1501 S MOONEY BLVD

**City of Visalia**  
**Building: Site Plan**  
**Review Comments**

NOTE: These are general comments and DO NOT constitute a complete plan check for your specific project  
Please refer to the applicable California Code & local ordinance for additional requirements.

- A building permit will be required. *For information call (559) 713-4444*
- Submit 1 digital set of professionally prepared plans and 1 set of calculations. (Small Tenant Improvements)
- Submit 1 digital set of plans prepared by an architect or engineer. Must comply with 2016 California Building Cod Sec. 2308 for conventional light-frame construction or submit 1 digital set of engineered calculations.
- Indicate abandoned wells, septic systems and excavations on construction plans.
- You are responsible to ensure compliance with the following checked items:**
- Meet State and Federal requirements for accessibility for persons with disabilities.
- A path of travel, parking and common area must comply with requirements for access for persons with disabilities.
- All accessible units required to be adaptable for persons with disabilities.
- Maintain sound transmission control between units minimum of 50 STC.
- Maintain fire-resistive requirements at property lines.
- A demolition permit & deposit is required. *For information call (559) 713-4444*
- Obtain required permits from San Joaquin Valley Air Pollution Board. *For information call (661) 392-5500*
- Plans must be approved by the Tulare County Health Department. *For information call (559) 624-8011*
- Project is located in flood zone \_\_\_\_\_ \*  Hazardous materials report.
- Arrange for an on-site inspection. (Fee for inspection \$157.00) *For information call (559) 713-4444*
- School Development fees. Commercial \$0.61 per square foot. Residential \$3.79 per square foot.
- Park Development fee \$\_\_\_\_\_, per unit collected with building permits.
- Existing address must be changed to be consistent with city address. *For information call (559) 713-4320*
- Acceptable as submitted
- No comments at this time

Additional comments: \_\_\_\_\_  
\_\_\_\_\_  
\_\_\_\_\_  
\_\_\_\_\_

VAL GARCIA 2/2/18  
Signature



**Site Plan Review Comments For:**

Visalia Fire Department  
Kurtis A. Brown, Fire Marshal  
420 N. Burke  
Visalia, CA 93291  
559-713-4261 Office  
559-713-4808 Fax

Date: 08/08/2018

Item # 7

Site Plan # 18140

Project: 1501 S. MOONEY COMM. RETAIL BLDG.

Description: PROPOSED COMM. CONDOMINIUM

Applicant: MATT NOHE

Location: 1501 S. MOONEY

APN: 0915-160-092

**The following comments are applicable when checked:**

- The Site Plan Review comments are issued as general overview of your project. With further details, additional requirements will be enforced at the Plan Review stage. Please refer to the 2016 California Fire Code (CFC), 2016 California Building Codes (CBC) and City of Visalia Municipal Codes.
- All fire detection, alarm, and extinguishing systems in existing buildings shall be maintained in an operative condition at all times and shall be replaced or repaired where defective. If building has been vacant for a significant amount of time, the fire detection, alarm, and or extinguishing systems may need to be evaluated by a licensed professional. *2016 CFC 901.6*
- No fire protection items required for parcel map or lot line adjustment; however, any future projects will be subject to fire & life safety requirements including fire protection.
- Construction and demolition sites prior to and during construction shall comply with the following:
  - Water Supply for fire protection, either temporary or permanent, shall be made available as soon as combustible materials arrive on the site. *2016 CFC 3312*
  - An all-weather, 20 feet width Construction Access Road capable of holding a 75,000 pound fire apparatus. Fire apparatus access shall be provided within 100 feet of temporary or permanent fire department connections. *2016 CFC 3310*
- More information is needed before a Site Plan Review can be conducted. Please submit plans with more detail. Please include information on

**General:**

- Address numbers must be placed on the exterior of the building in such a position as to be clearly and plainly visible from the street. Numbers will be at least four inches (4") high and shall be of a color to contrast with their background. If multiple addresses served are by a common driveway, the range of numbers shall be posted at the roadway/driveway. *2016 CFC 505.1*
- All hardware on exit doors, illuminated exit signs and emergency lighting shall comply with the 2016 California Fire Code. This includes all locks, latches, bolt locks, panic hardware, fire exit hardware and gates.
- Commercial dumpsters with 1.5 cubic yards or more shall not be stored or placed within 5 feet of combustible walls, openings, or a combustible roof eave line except when protected by a fire sprinkler system. *2016 CFC 304.3.3*

- A Knox Box key lock system is required. Where access to or within a structure or area is restricted because of secured openings (doors and/or gates), a key box is to be installed in an approved location. The key box shall be ordered using an approved Knox Authorization Order Form. The forms are located at the fire department administration office located at 707 W. Acequia, Visalia, CA 93291. Please allow adequate time for shipping and installation. *2016 CFC 506.1*
- If your business handles hazardous material in amounts that exceed the Maximum Allowable Quantities listed on *Table 5003.1.1(1), 5003.1.1(2), 5003.1.1(3) and 5003.1.1(4) of the 2016 California Fire Code*, you are required to submit an emergency response plan to the Tulare County Health Department. Also you shall indicate the quantities on your building plans and prior to the building final inspection a copy of your emergency response plan and Safety Data Sheets shall be submitted to the Visalia Fire Department.

**Water Supply for Residential, Commercial & Industrial:**

Residential

- Fire hydrant spacing and location shall comply with the following requirements:  
The exact location and number of fire hydrants shall be at the discretion of the fire marshal, fire chief and/or their designee. *Visalia Municipal Code 16.36.120(5)*
  - Single-family residential developments shall be provided with fire hydrants every six hundred (600) lineal feet of residential frontage. In isolated developments, no less than two (2) fire hydrants shall be provided.
  - Multi-family, zero lot line clearance, mobile home park or condominium developments shall be provided with fire hydrants every four hundred (400) lineal feet of frontage. In isolated developments, no less than two (2) fire hydrants shall be provided.
  - Multi-family or condominium developments with one hundred (100) percent coverage fire sprinkler systems shall be provided with fire hydrants every six (600) lineal feet of frontage. In isolated developments, no less than two (2) fire hydrants shall be provided.

Commercial & Industrial

- Where a portion of the facility or building is more than 400 feet from a hydrant on a fire apparatus access road, on-site fire hydrant(s) shall be provided. *2016 CFC 507.5.1*
- Due to insufficient building information, the number and distance between fire hydrants cannot be determined by the Site Plan Review process. The number of fire hydrants and distance between required fire hydrants shall be determined by utilizing type of construction and square footage in accordance with *CFC 2016 Appendix C102 & C103 & CFC 507.5.1*
- To determine fire hydrant location(s) and distribution the following information was provided to the Site Plan Review committee: **Type of construction** \_\_\_\_\_ **Square footage** \_\_\_\_\_

**Emergency Access**

- A fire apparatus access roads shall be provided and must comply with the 2016 CFC and extend within 150 of all portions of the facility and all portions of the exterior walls of the first story of the building as measured by an approved route around the exterior of the building or facility. Fire apparatus access

roads shall have an unobstructed width of not less than 20 feet. Minimum turning radius for emergency fire apparatus shall be 20 feet inside radius and 43 feet outside radius. 2016 CFC 503.1.1

- Buildings or portions of buildings or facilities with a vertical distance between the grade plan and the highest roof surface that exceed 30 feet shall provide an approved fire apparatus access roads capable of accommodating fire department aerial apparatus.
  - Access roads shall have a minimum unobstructed width of 26 feet, exclusive of shoulders.
  - Access routes shall be located within a minimum of 15 feet and maximum of 30 feet from the building, and shall be positioned parallel to one entire side of the building.
  - Overhead utility and power lines shall not be located over the aerial fire apparatus access road or between the aerial fire apparatus road and the building.
  
- Fire apparatus access roads in excess of 150 feet and dead end shall be provided with a turnaround. Fire apparatus access roads with a length of 151-500 feet shall be a minimum of 20 feet in width. Length of 501-750 feet shall be 26 feet in width. 2016 CFC Table D103.4

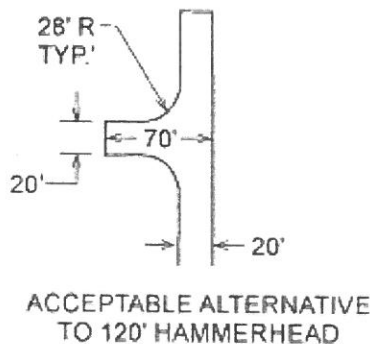
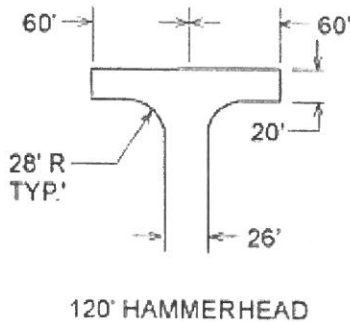
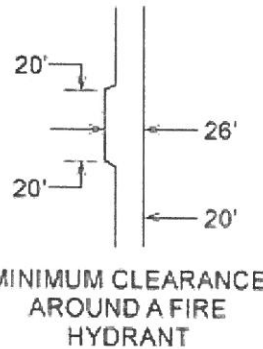
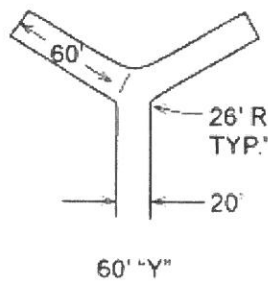
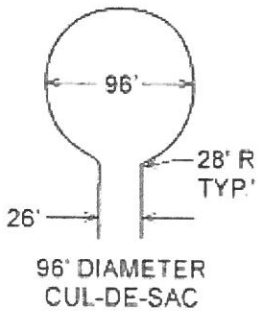

- Approved No PARKING – FIRE LANE signs shall be provided for fire apparatus access roads to identify such roads or prohibit the obstruction thereof. Signs shall have a minimum dimension of 12 inches wide by 18 inches high and have red letters on a white reflective background. 2013 CFC 503.3/D103.6



- On site Fire Apparatus Access Roads shall be provided and have an unobstructed width of not less than the following;
  - 20 feet width, exclusive of shoulders (No Parking)
  - More than 26 feet width, exclusive of shoulders (No Parking one side)
  - More than 32 feet wide, exclusive of shoulders (Parking permitted on both sides)
  
- Marking- approved signs, other approved notices or marking that include the words "NO PARKING-FIRE LANE shall be provided for fire apparatus access roads to identify such roads or prohibit the obstruction thereof. *CFC 503.3*
  
- Gates on access roads shall be a minimum width of 20 feet and shall comply with the following:  
*2016 CFC D103.5*
  - Gates shall be of the swinging or sliding type.
  - Gates shall allow manual operation by one person (power outages).
  - Gates shall be maintained in an operative condition at all times.
  - Electric gates shall be equipped with a means of opening the gate by fire department personnel for emergency access. (Note: Knox boxes shall be ordered using an approved Knox Authorization Order Form. The forms are located at the fire department administration office located at 707 W. Acequia, Visalia, CA 93291. Please allow adequate time for shipping and installation.)
  
- Streets shall meet the City of Visalia's Design & Improvement Standards for streets to ensure that fire apparatus can make access to all structures in the event of an emergency.

### **Fire Protection Systems**

- An automatic fire sprinkler system will be required for this building. Also, a fire hydrant is required within 50 feet of the Fire Department Connection (FDC). Where an existing building is retrofitted with a sprinkler system (NFPA 13 or NFPA 13R) a fire hydrant shall be provided within 75 feet of the FDC. An additional 25 feet of distance between a fire hydrant and FDC may be granted when a fire sprinkler Density is designed with an additional 25%. *2016 CFC 912 and Visalia Municipal Code 8.20.010 subsection C103.4*
  
- Locking fire department connection (FDC) caps are required. The caps shall be ordered using an approved Knox Authorization Order Form. The forms are located at the fire department administration office located at 707 W. Acequia, Visalia, CA 93291. *2016 CFC 912.4.1*
  
- Commercial cooking appliances and domestic cooking appliances used for commercial purposes that produces grease laden vapors shall be provided with a Type 1 Hood, in accordance with the California Mechanical Code, and an automatic fire extinguishing system. *2016 CFC 904.12 & 609.2*

### **Special Comments:**

  
Kurtis A. Brown  
Fire Marshal



SPR18140

**City of Visalia  
Police Department**

303 S. Johnson St.  
Visalia, Ca. 93292  
(559) 713-4370

**Site Plan Review Comments**

- No Comment at this time.
- Request opportunity to comment or make recommendations as to safety issues as plans are developed.
- Public Safety Impact fee:  
Ordinance No. 2001-11 Chapter 16.48 of Title 16 of the Visalia Municipal Code  
Effective date - August 17, 2001

Impact fees shall be imposed by the City pursuant to this Ordinance as a condition of or in conjunction with the approval of a development project. "New Development or Development Project" means any new building, structure or improvement of any parcels of land, upon which no like building, structure of improvement previously existed. \*Refer to Engineering Site Plan comments for fee estimation.

- Not enough information provided. Please provide additional information pertaining to:  
\_\_\_\_\_
- Territorial Reinforcement: Define property lines (private/public space).  
\_\_\_\_\_
- Access Controlled / Restricted etc:  
\_\_\_\_\_
- Lighting Concerns:  
\_\_\_\_\_
- Landscaping Concerns:  
\_\_\_\_\_
- Traffic Concerns:  
\_\_\_\_\_
- Surveillance Issues:  
\_\_\_\_\_
- Line of Sight Issues:  
\_\_\_\_\_
- Other Concerns:  
\_\_\_\_\_

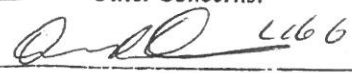
 2166

# SITE PLAN REVIEW COMMENTS

CITY OF VISALIA TRAFFIC SAFETY DIVISION

August 8, 2018

**ITEM NO. 7**

SITE PLAN NO: SPR18140  
PROJECT TITLE: 1501 S. Mooney Commercial Retail Building  
DESCRIPTION: Proposed Commercial Condominium, Establish 2 Commercial Condominiums w/ Common Size Parcel  
APPLICANT: Matt Nohr  
OWNER: West End Partners, LLC  
APN: 095-160-092  
LOCATION: 1501 S Mooney Blvd

**THE TRAFFIC DIVISION WILL PROHIBIT ON-STREET PARKING AS DEEMED NECESSARY**

- No Comments
- See Previous Site Plan Comments
- Install Street Light(s) per City Standards.
- Install Street Name Blades at Locations.
- Install Stop Signs at Locations.
- Construct parking per City Standards PK-1 through PK-4.
- Construct drive approach per City Standards.
- Traffic Impact Analysis required.
  - Provide more traffic information such as . Depending on development size, characteristics, etc., a TIA may be required.

**Additional Comments:**



Leslie Blair

18140

COMMERCIAL BIN SERVICE

XX

No comments.

See comments below

Revisions required prior to submitting final plans. See comments below.

Resubmittal required. See comments below.

Customer responsible for all cardboard and other bulky recyclables to be broken down before disposing of in recycle containers

ALL refuse enclosures must be R-3 OR R-4

Customer must provide combination or keys for access to locked gates/bins

Type of refuse service not indicated.

Location of bin enclosure not acceptable. See comments below.

Bin enclosure not to city standards double.

Inadequate number of bins to provide sufficient service. See comments below.

Drive approach too narrow for refuse trucks access. See comments below.

Area not adequate for allowing refuse truck turning radius of : Commercial ( X ) 50 ft. outside 36 ft. inside; Residential ( ) 35 ft. outside, 20 ft. inside.

Paved areas should be engineered to withstand a 55,000 lb. refuse truck.

Bin enclosure gates are required

Hammerhead turnaround must be built per city standards.

Cul - de - sac must be built per city standards.

Bin enclosures are for city refuse containers only. Grease drums or any other items are not allowed to be stored inside bin enclosures.

Area in front of refuse enclosure must be marked off indicating no parking

Enclosure will have to be designed and located for a STAB service (DIRECT ACCESS) with no less than 38' clear space in front of the bin, included the front concrete pad.

Customer will be required to roll container out to curb for service.

Must be a concrete slab in front of enclosure as per city standards, the width of the enclosure by ten(10) feet, minimum of six(6) inches in depth.

Roll off compactor's must have a clearance of 3 feet from any wall on both sides and there must be a minimum of 53 feet clearance in front of the compactor to allow the truck enough room to provide service.

City ordinance 8.28.120-130 (effective 07/19/18) requires contractor to contract with City for removal of construction debris unless transported in equipment owned by contractor or unless contracting with a franchise permittee for removal of debris utilizing roll-off boxes.

Comment

**Site Plan Review Comments For:**

California Water Service Co.  
Mike Morton, Superintendent  
216 N. Valley Oaks Dr.  
Visalia, CA 93292  
559-624-1663 Office  
559-735-3189 Fax

Date: 08/08/2018

Item # Choose an item.

Site Plan # 18140

Project:

Description:

Applicant:

Location: 1501 S. Mooney

APN:

**The following comments are applicable when checked:**

No Comments at this time

Fire Hydrants  
Comments-

Service's  
Comments-

Main's  
Comments-

Back flow requirements  
Comments-

**Additional Comments:**

---

Mike Morton  
Superintendent

## Brandon Smith

---

**From:** Deel, David@DOT <david.deel@dot.ca.gov>  
**Sent:** Thursday, January 10, 2019 12:29 PM  
**To:** Brandon Smith  
**Cc:** Navarro, Michael@DOT  
**Subject:** RE: Visalia Site Plan Review No. 2018-140

Brandon –

I very much appreciate your follow up with Caltrans on this project.

I typically provide my ‘no comment’ response to the SPR Agenda to Susan Currier, with a cc to Adrian Rubalcaba and Paul Bernal.

As we spoke, Caltrans determined the project was a ***no comment*** based on the following:

1. The project is a remodel of the building for the Commercial Condos (which was existing as a bank or retail space) with existing access to SR 63 via a driveway for the retail/commercial shopping center the condos are located within.
1. Per the site plan, it appears the boundaries of the project were limited to the parking lot area and remodel of the existing building and did not propose any changes to the driveway for SR 63.
1. Since the Commercial Condos remodel does not change ownership of the existing property, I assumed that no update to the existing encroachment permit allowing access to SR 63 was needed.
1. The project is located mid-block, with a left turn lane (no signal) for access to Feemster Ave (which runs along the north side of the project site with existing driveway to Condo project and the shopping center). Therefore I determined that no additional improvements (ie: possible lengthening let turn storage area to increase queueing) to the left turn lane was needed or possible.
1. State Route 63 was recently widened to 6-lanes and therefore no additional right-of-way dedication is needed. The Caltrans Transportation Concept Report (TCR) for SR 63 states the *Ultimate* configuration of SR 63 is the current 6-lane facility.

If any further questions, please call me.

Thanks,

**DAVID DEEL | 559.488.7396 | CALTRANS D6**

---

**From:** Brandon Smith  
**Sent:** Thursday, January 10, 2019 10:47 AM  
**To:** Deel, David@DOT  
**Cc:** Navarro, Michael@DOT  
**Subject:** Visalia Site Plan Review No. 2018-140

Good morning David,

Can you please confirm if Caltrans has any written comments for Visalia Site Plan Review Item No. 2018-140, which was scheduled on the agenda of August 8, 2018? This item is located at 1501 S. Mooney Boulevard (APN: 095-160-092), and is described as a proposed commercial condominium , to establish two commercial condominiums with a common site parcel at an existing commercial building. A scan of the site plan is attached to this email. I did not see any Caltrans comments in our file but want to confirm with you.

The City has received a formal application for tentative parcel map and conditional use permit that corresponds to the Site Plan Review item, and will be processing the application in the near future. A scan of the tentative parcel map is also attached to this email.

Thank you,

**Brandon Smith, AICP**

Senior Planner, City of Visalia

[brandon.smith@visalia.city](mailto:brandon.smith@visalia.city)

Phone: (559) 713-4636

Fax: (559) 713-4814

# Tentative Parcel Map No. 2018-04 and Conditional Use Permit No. 2018-29

The project site is located on the southwest corner of Mooney Boulevard and Feemster Avenue. (APN: 095-160-092)

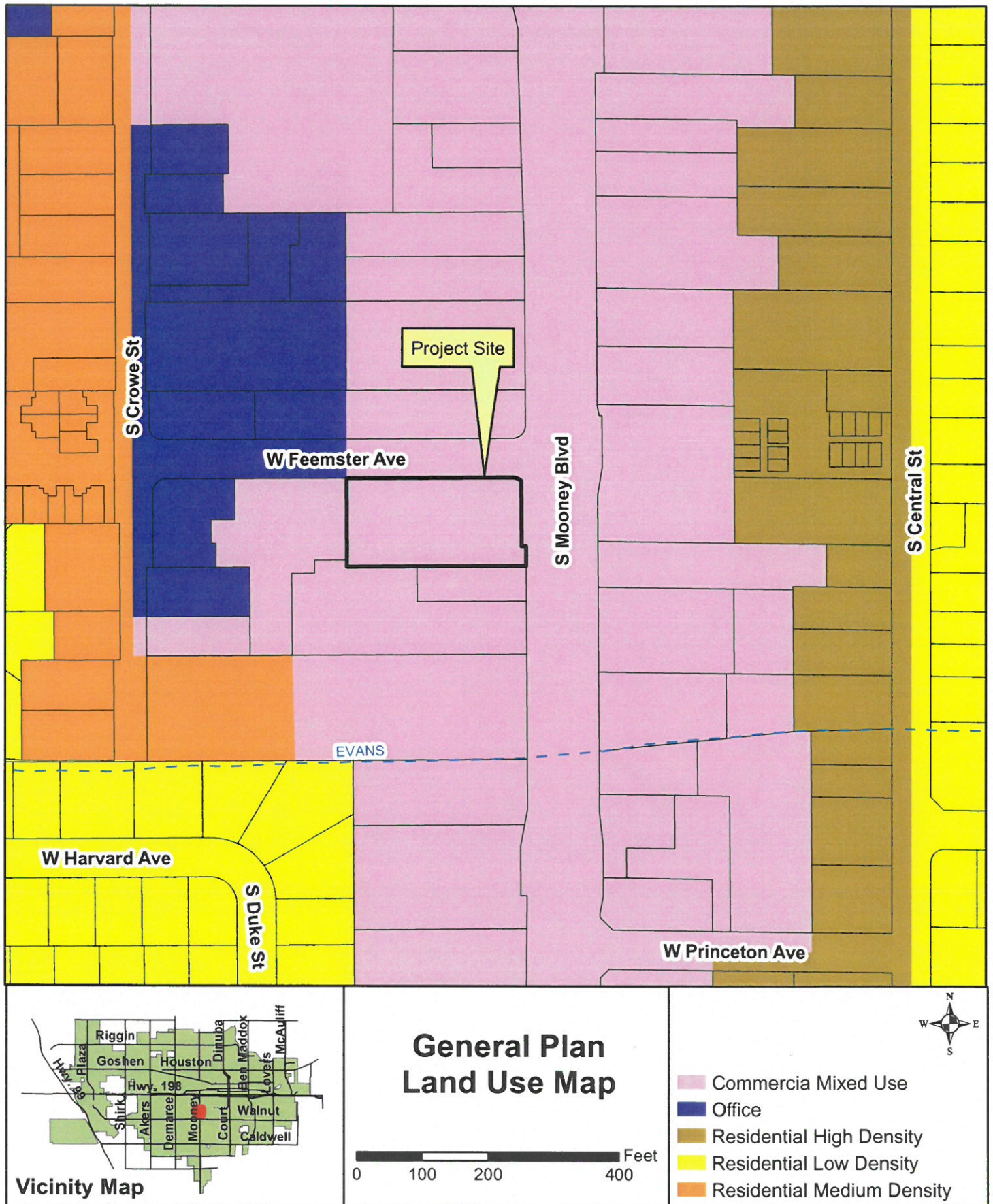

# Tentative Parcel Map No. 2018-04 and Conditional Use Permit No. 2018-29

The project site is located on the southwest corner of Mooney Boulevard and Feemster Avenue. (APN: 095-160-092)

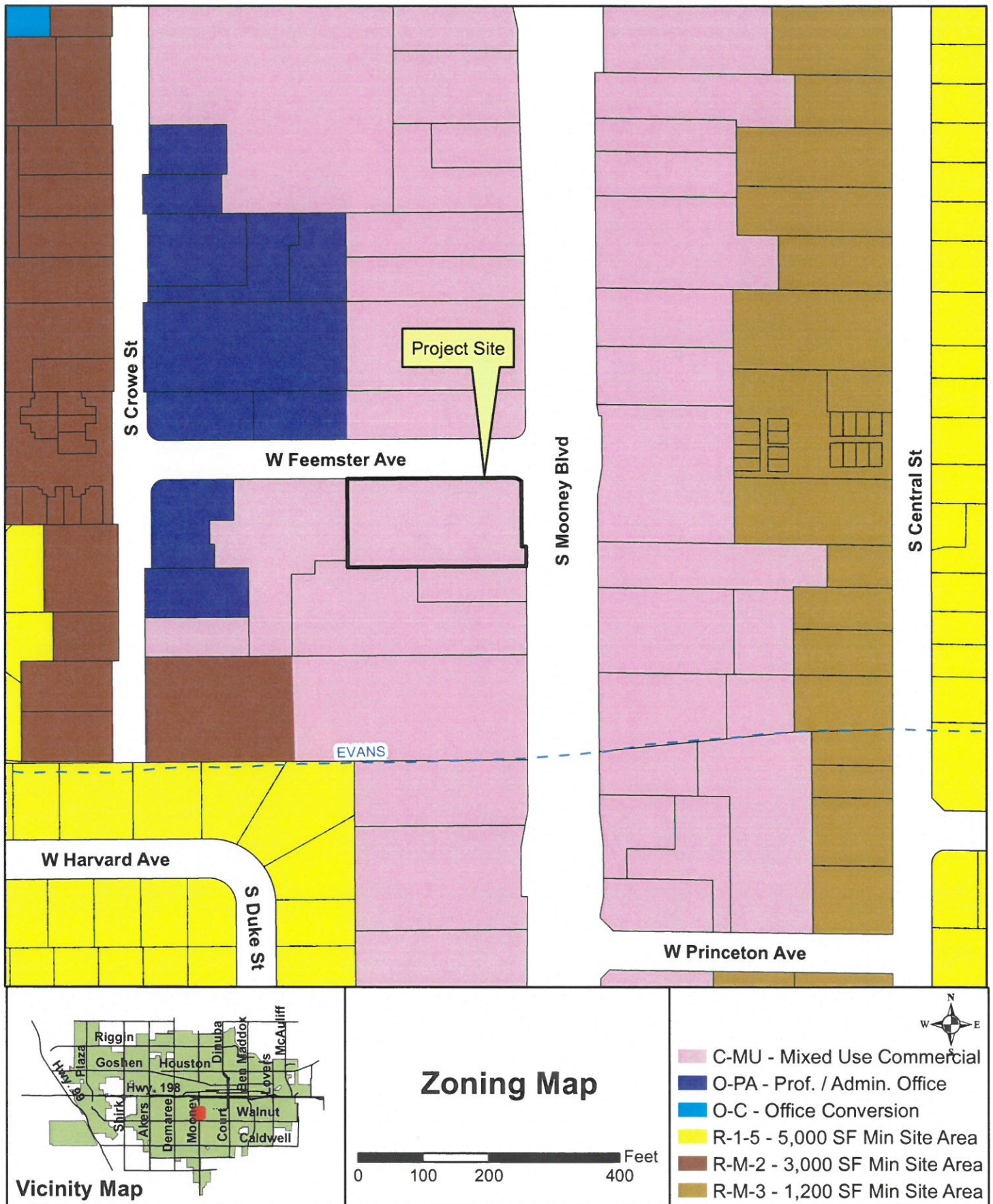

# Tentative Parcel Map No. 2018-04 and Conditional Use Permit No. 2018-29

The project site is located on the southwest corner of Mooney Boulevard and Feemster Avenue. (APN: 095-160-092)

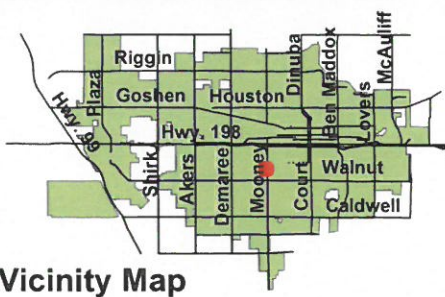

Vicinity Map

## Aerial Photo

Photo Taken March 2018

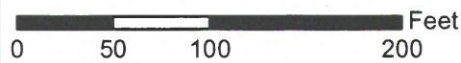

- WATERWAYS
- +— RAILROADS
- CITY LIMITS
- PARCELS





# Tentative Parcel Map No. 2018-04 and Conditional Use Permit No. 2018-29

The project site is located on the southwest corner of Mooney Boulevard and Feemster Avenue. (APN: 095-160-092)

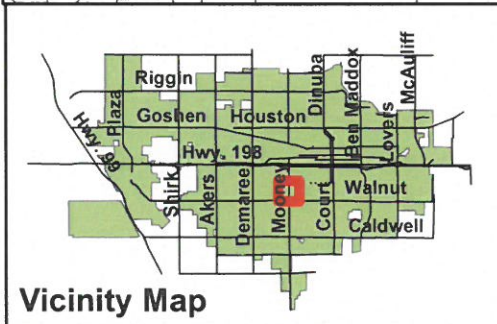
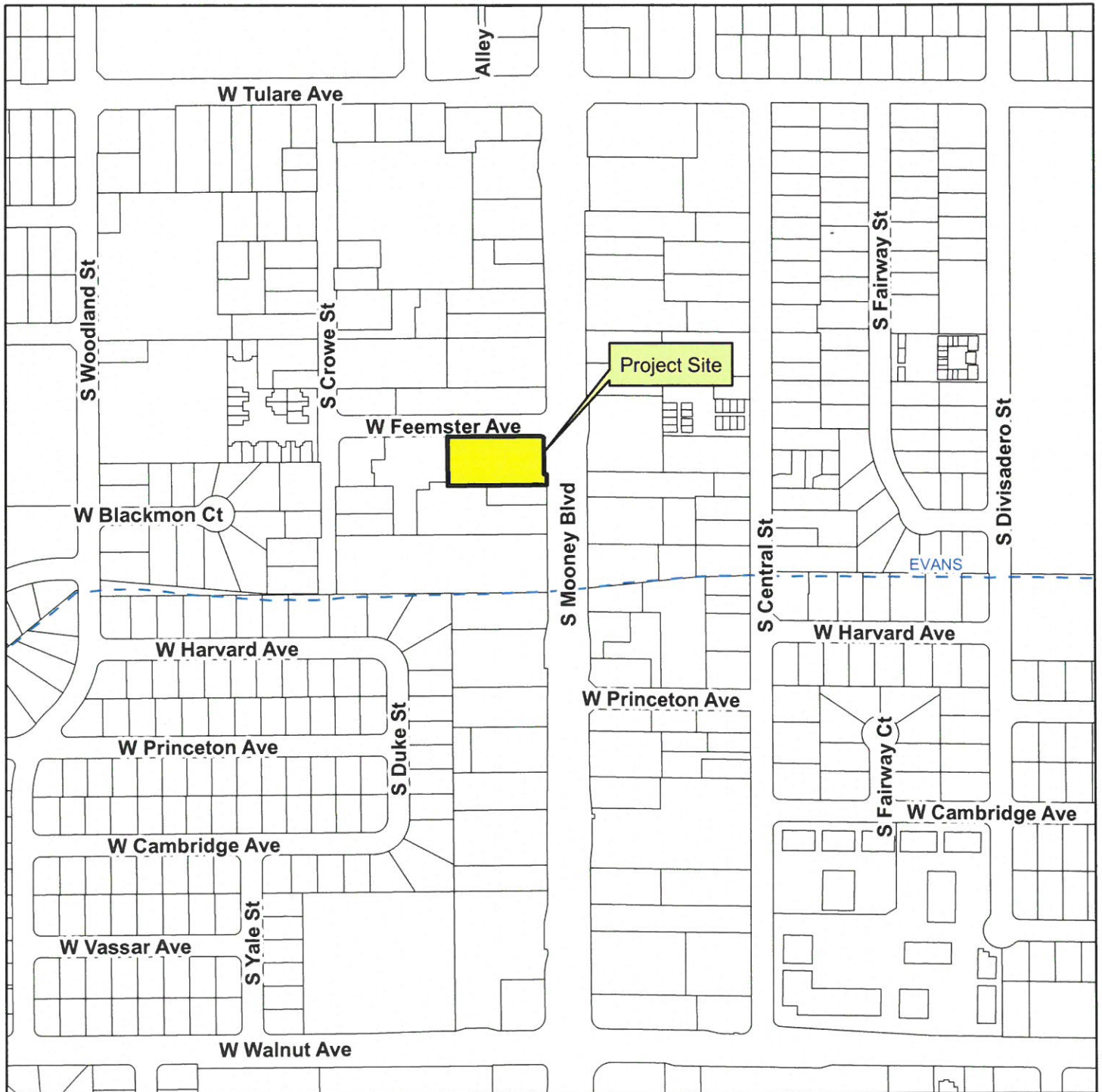

## Location Map

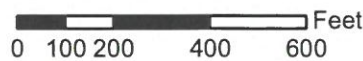

- WATERWAYS
- RAILROADS
- CITY LIMITS
- PARCELS

