

PLANNING COMMISSION AGENDA

CHAIRPERSON:

Brett Taylor



VICE CHAIRPERSON:

Liz Wynn

COMMISSIONERS: Adam Peck, Brett Taylor, Liz Wynn, Marvin Hansen, Chris Gomez

MONDAY, APRIL 24, 2017; 7:00 P.M., COUNCIL CHAMBERS, 707 W. ACEQUIA, VISALIA CA

1. THE PLEDGE OF ALLEGIANCE –
2. CITIZEN'S COMMENTS – This is the time for citizens to comment on subject matters that are not on the agenda but are within the jurisdiction of the Visalia Planning Commission. The Commission requests that a 5-minute time limit be observed for comments. Please begin your comments by stating and spelling your name and providing your street name and city. Please note that issues raised under Citizen's Comments are informational only and the Commission will not take action at this time.
3. CHANGES OR COMMENTS TO THE AGENDA–
4. CONSENT CALENDAR - All items under the consent calendar are to be considered routine and will be enacted by one motion. For any discussion of an item on the consent calendar, it will be removed at the request of the Commission and made a part of the regular agenda.
 - No Items on the Consent Calendar
5. PUBLIC HEARING – Andy Chamberlain
Conditional Use Permit No. 2017-08: A request by Christopher Owhadi to construct a 200 Unit apartment complex with a Community Building in the R-M-2 (Medium Density Residential) zone. The site is located on the northeast corner of Shirk Street and Doe Avenue (APN: 077-530-065, 077-530-066, 077-750-001, and 077-740-001). Initial Study No. 2017-13 disclosed that environmental impacts are determined to be not significant. The Environmental Impact Report prepared for the City of Visalia General Plan was certified by Resolution No. 2014-37, adopted on October 14, 2015. The Environmental Impact Report adequately analyzed and addressed the proposed project.
6. PUBLIC HEARING – Brandon Smith *Continued from 03/27/2017*
Variance No. 2017-06: A request by Yesco Signs, LLC (DBO Development No. 33, property owner), to allow a variance to the maximum sign area associated with wall signage in the Regional Retail Commercial (C-R) Zone. The site is located at 1650 W. Visalia Parkway, on the north side of Visalia Parkway one-quarter mile east of Mooney Boulevard. (APN: 126-730-026, 027) The project is Categorically Exempt from the California Environmental Quality Act (CEQA) pursuant to CEQA Guidelines Section 15305, Categorical Exemption No. 2017-14.
7. PUBLIC HEARING – Paul Scheibel
Appeal of the Revocation of Home Occupation Permit (HOC) No. 2016-79 for a Limousine Service with two limousines located at the HOC residence, 640 W. Kimball Avenue (APN: 126-570-007).

8. PUBLIC HEARING – Brandon Smith

Conditional Use Permit No. 2017-09: A request by Noble Chicken LLC (RREF II-WPG Visalia, LLC, property owner), to allow development of a new fast food restaurant with drive-thru lane in the C-MU (Commercial Mixed Use) zone. The project site is located on the south side of Noble Avenue approximately 400 feet east of Demaree Street. (APN: 095-010-059) The project is Categorically Exempt from the California Environmental Quality Act (CEQA) pursuant to CEQA Guidelines Section 15332, Categorical Exemption No. 2017-18.

9. PUBLIC HEARING – Andy Chamberlain

Tentative Parcel Map No. 2016-03: A request by the TC Investments Visalia, LLC, applicant (Alfred Chang, property owner) to divide a 3.68 acre parcel into a 1.97 acre, and 1.71 acre parcel, in the C-MU (Commercial Mixed Use) zone. The project is located at 5625 W. Cypress Avenue (APN: 087-450-022). The project is Categorically Exempt from the California Environmental Quality Act (CEQA) pursuant to CEQA Guidelines Section 15315, Categorical Exemption No. 2017-25.

10. PUBLIC HEARING – Paul Scheibel

a. Reimer Tentative Subdivision Map No. 5559: A request to subdivide 15.2 acres into 65 lots and a remainder parcel for residential development. The project is zoned R-1-6 (Single-family Residential, 6,000 sq. ft. minimum lot size), and is located on the south side of K Road, approximately 230 feet east of Burke Road. (APNs 123-090-008, -014, and 123-100-004) An Initial Study was prepared for this project, consistent with CEQA, which disclosed that environmental impacts are determined to be not significant with mitigation and that Negative Declaration No. 2017-17 was adopted.

b. Annexation No. 2017-01: A request to annex three parcels totaling 15.2 acres into the City limits of Visalia, and to detach from Tulare County Service Area No.1. Upon annexation, the site would be zoned R-1-6 (Single-Family Residential 6,000 square foot minimum site area), which is consistent with the General Plan Land Use Designation of Low Density Residential. The site is located on the south side of K Road, approximately 230 feet east of Burke Road. (APNs 123-090-008, -014, and 123-100-004) An Initial Study was prepared for this project, consistent with CEQA, which disclosed that environmental impacts are determined to be not significant with mitigation and that Negative Declaration No. 2017-17 was adopted.

11. DIRECTOR'S REPORT/ PLANNING COMMISSION DISCUSSION-

- Economic Update - Business Boom

The Planning Commission meeting may end no later than 11:00 P.M. Any unfinished business may be continued to a future date and time to be determined by the Commission at this meeting. The Planning Commission routinely visits the project sites listed on the agenda.

For the hearing impaired, if signing is desired, please call (559) 713-4359 twenty-four (24) hours in advance of the scheduled meeting time to request these services. For the visually impaired, if enlarged print or Braille copy is desired, please call (559) 713-4359 for this assistance in advance of the meeting and such services will be provided as soon as possible following the meeting.

Any written materials relating to an item on this agenda submitted to the Planning Commission after distribution of the agenda packet are available for public inspection in the City Office, 315 E. Acequia Visalia, CA 93291, during normal business hours.

APPEAL PROCEDURE

THE LAST DAY TO FILE AN APPEAL IS THURSDAY, MAY 4, 2017 BEFORE 5 PM

According to the City of Visalia Zoning Ordinance Section 17.02.145 and Subdivision Ordinance Section 16.04.040, an appeal to the City Council may be submitted within ten days following the date of a decision by the Planning Commission. An appeal form with applicable fees shall be filed with the City Clerk at 220 N. Santa Fe, Visalia, CA 93292. The appeal shall specify errors or abuses of discretion by the Planning Commission, or decisions not supported by the evidence in the record. The appeal form can be found on the city's website www.visalia.city or from the City Clerk.

THE NEXT REGULAR MEETING WILL BE HELD ON MONDAY, MAY 8, 2017



REPORT TO CITY OF VISALIA PLANNING COMMISSION

HEARING DATE: April 24, 2017

PROJECT PLANNER: Paul Scheibel, AICP, Principal Planner
Phone No.: (559) 713-4369

SUBJECT: Reimer Tentative Subdivision Map No. 5559: A request to subdivide 15.2 acres into 65 lots and a remainder parcel for residential development. The project is pre-zoned R-1-5 (Single-family Residential, 5,000 sq.ft. minimum lot size), and is located on the south side of K Road, approximately 230 feet east of Burke Road. (APNs 123-090-008 -014, and 123-100-004).

Reimer Annexation No. 2017-01: A request to annex three parcels totaling 15.2 acres into the City limits of Visalia, and to detach from Tulare County Service Area No.1. Upon annexation, the site would be zoned R-1-5 (Single-family Residential, 5,000 sq.ft. minimum lot size), which is consistent with the General Plan Land Use designation of Low Density Residential. The site is located on the south side of K Road, approximately 230 feet east of Burke Road (APNs 123-090-008, -014, and 123-100-004).

STAFF RECOMMENDATION

Tentative Subdivision Map No. 5559

Staff recommends approval of Tentative Subdivision Map No. 5559, as conditioned, based on the findings and conditions in Resolution No. 2017-11. Staff's recommendation is based on the conclusion that the request is consistent with the Visalia General Plan, Zoning and Subdivision Ordinances.

Annexation No. 2017-01

Staff recommends that the Planning Commission recommend approval of Annexation No. 2017-01, as conditioned, based on the findings in Resolution No. 2017-25. Staff's recommendation is based on the conclusion that the request is consistent with the Visalia General Plan.

RECOMMENDED MOTION

I move to approve Tentative Subdivision Map No. 5559, based on the findings and conditions in Resolution No. 2017-11.

I move to recommend approval of Annexation No. 2017-01, based on the findings and conditions in Resolution No. 2017-25.

PROJECT DESCRIPTION

The project proponents are requesting to annex and subdivide a 15.2-acre site that is currently in the K Road County Island in unincorporated Tulare County. Tentative Subdivision Map (TSM) No. 5559 would create 65 single-family residential lots on a 12.2-acre portion of the site. The remaining three-acre portion is identified as a Remainder parcel.

TSM No. 5559

The General Plan Land Use Diagram, adopted October 14, 2014, designates the project area as Low Density Residential. The Zoning Map, adopted in 1993, identifies the proposed annexation site as County A-20 (Agriculture, 20-acre minimum lot size), since the City does not exercise Zoning authority over unincorporated lands. If successfully annexed, the project area will be zoned R-1-5, which is consistent with the General Plan Land Use Designation of Low Density Residential, as noted in Table 9-1 "Consistency Between the Plan and Zoning" of the General Plan.

The proposed project is consistent with Land Use Policies LU-P-19 of the General Plan. Policy LU-P-19 states; "Ensure that growth occurs in a compact and concentric fashion by implementing the General Plan's phased growth strategy." The site that is proposed for development is within a County Island, and is bounded on three sides by existing urban development. There is utility infrastructure that can be extended from nearby urban development to accommodate the project at buildout. Further, the site is in the Tier 1 Growth Boundary (UDB), which allows for immediate development upon successful annexation.

LU-P-20 states, "allow annexation and development of residential, commercial, and industrial land to occur within the "Tier I" UDB at any time, consistent with the City's Land Use Diagram." The project is located in the Tier 1 UDB.

Further, the project is consistent with Policy LU-P-34. The conversion of the site from an agricultural use does not require mitigation to offset the loss of prime farmland as stated in Policy LU-P-34. The policy states; "the mitigation program shall specifically allow exemptions for conversion of agricultural lands in Tier I."

The proposed TSM meets all of the codified standards contained in the Zoning and Subdivision Ordinances, as well as all General Plan policies pertaining to residential development. The remainder portion of the project area is not proposed for development at this time. Future single-family residential development can be facilitated by connection to the new local road that will extend to K Road.

Annexation No. 2017-01

The project proponents have also filed an application to initiate the annexation. This is necessary to bring the 15.2-acre portion of the project area that includes the subdivision site into the City's land use jurisdiction. The Annexation can be supported on the basis that the proposed use of the site for residential development is consistent with the Low Density Residential land use designation on the site. Additionally, the site is within a County Island, and is adjacent to existing urban development. It has all requisite utility and infrastructure available to serve the site upon development. Finally, the annexation will reduce the size of an existing County Island, which is encouraged by LAFCO policies.

Cities are allowed to approve tentative maps prior to annexation, but may not approve the final subdivision map until after the land is annexed. The Tulare County Local Agency Formation Commission will need to approve and record the annexation prior to the map being effective. Staff has included this requirement as a condition of TSM 5559.

Recommended Conditions

In addition to the standard conditions applicable to a TSM, staff recommends the following Special Conditions to be placed on the TSM:

- Approval of TSM 5559 shall not become effective unless Annexation No. 2017-01, placing the project site within the corporate limits of the City of Visalia, is approved by the

Tulare County Local Agency Formation Commission (LAFCO), and is fully executed to include all conditions contained in the Pre-Annexation Agreement for Annexation No. 2017-01.

- K Road: The developer shall provide necessary right of way and complete construction of K Road along the full frontage of the project site, including the Remainder parcel. Such right of way and improvements shall be subject to the review and approval of the Community Development Director.

These road improvements are necessary to providing local and area-wide vehicular and pedestrian circulation. Portion of the road improvements may be reimbursable to the project proponent.

Subdivision Map Act Findings

California Government Code Section 66474 lists seven findings for which a legislative body of a city or county shall deny approval of a tentative map if it is able to make any of these findings. These seven “negative” findings have come to light through a recent California Court of Appeal decision (*Spring Valley Association v. City of Victorville*) that has clarified the scope of findings that a city or county must make when approving a tentative map under the California Subdivision Map Act.

Staff has reviewed the seven findings for a cause of denial and finds that none of the findings can be made for the proposed project. The seven findings and staff’s analysis are below. Recommended findings in response to this Government Code section are included in the recommended findings for the approval of the tentative parcel map.

<u>GC Section 66474 Finding</u>	<u>Analysis</u>
(a) That the proposed map is not consistent with applicable general and specific plans as specified in Section 65451.	The proposed map has been found to be consistent with the City’s General Plan. This is included as recommended Finding No. 1 of the Tentative Subdivision Map. There are no specific plans applicable to the proposed map.
(b) That the design or improvement of the proposed subdivision is not consistent with applicable general and specific plans.	The proposed design and improvement of the map has been found to be consistent with the City’s General Plan. This is included as recommended Finding No. 1 of the Tentative Subdivision Map. There are no specific plans applicable to the proposed map.
(c) That the site is not physically suitable for the type of development.	The site is physically suitable for the proposed map and its affiliated development plan, which is designated as Low Density Residential. This is included as recommended Finding No. 3 of the Tentative Subdivision Map.
(d) That the site is not physically suitable for the proposed density of development.	The site is physically suitable for the proposed map and its affiliated development plan, which is designated as Low Density Residential. This is included as recommended Finding No. 4 of the Tentative Subdivision Map.
(e) That the design of the subdivision or the proposed improvements are likely to cause substantial environmental damage or substantially and avoidably injure fish	The proposed design and improvement of the map, with mitigation measures applied, has been not been found likely to cause environmental damage or substantially and avoidable injure fish

or wildlife or their habitat.	or wildlife or their habitat. This finding is further supported by the project's Negative Declaration under the Guidelines for the Implementation of the California Environmental Quality Act (CEQA), included as recommended Finding No. 6 of the Tentative Subdivision Map.
(f) That the design of the subdivision or type of improvements is likely to cause serious public health problems.	The proposed design of the map has been found to not cause serious public health problems. This is included as recommended Finding No. 2 of the Tentative Subdivision Map.
(g) That the design of the subdivision or the type of improvements will conflict with easements, acquired by the public at large, for access through or use of, property within the proposed subdivision.	The proposed design of the map does not conflict with any existing or proposed easements located on or adjacent to the subject property. This is included as recommended Finding No. 5 of the Tentative Subdivision Map.

Environmental Review

Negative Declaration No. 2017-17 has been prepared for the project. The 20-day review and comment period for the Initial Study began on March 30, 2017, and ended on April 24, 2017. No formal comments have been received. Consequently, the Negative Declaration for the project is recommended for adoption.

RECOMMENDED FINDINGS

Tentative Subdivision Map No. 5559

1. That the proposed location and layout of the Reimer Tentative Subdivision Map No. 5559, its improvement and design, and the conditions under which it will be maintained is consistent with the policies and intent of the General Plan, Zoning Ordinance, and Subdivision Ordinance. The 15.2-acre project site, which is the site of the proposed 65-lot residential subdivision, with a remainder parcels is specifically consistent with General Plan Land Use policies LU-P-19 and LU-P45 related to efficient land use absorption.
2. That the proposed Reimer Tentative Subdivision Map No. 5559, its improvement and design, and the conditions under which it will be maintained will not be detrimental to the public health, safety, or welfare, nor materially injurious to properties or improvements in the vicinity, nor is it likely to cause serious public health problems. That the proposed tentative subdivision map would be compatible with adjacent land uses. The project site is bordered by existing urban roads and development to the north, south and west.
3. That the site is physically suitable for the proposed tentative subdivision map. The Reimer Tentative Subdivision Map No. 5559 is consistent with the intent of the General Plan, Subdivision Ordinance, and Zoning Ordinance, and is not detrimental to the public health, safety, or welfare or materially injurious to properties or improvements in the vicinity. The 65-lot subdivision is designed to comply with the City's Engineering Improvement Standards. This includes a second point of access to the subdivision and extension of a local road within TSM 5559 to connect with K Road.
4. That the site is physically suitable for the proposed tentative subdivision map and the project's density, which is consistent with the underlying Low Density Residential General Plan Land Use Designations. The proposed location and layout of the Reimer Tentative

Subdivision Map No. 5559, its improvement and design, and the conditions under which it will be maintained is consistent with the policies and intent of the General Plan, Zoning Ordinance, and Subdivision Ordinance.

5. That the Reimer Tentative Subdivision Map No. 5559 design of the subdivision or the type of improvements will not conflict with easements, acquired by the public at large, for access through or use of, property within the proposed subdivision. The 65-lot subdivision and Remainder parcel is designed to comply with the City's Engineering Improvement Standards.
6. That an Initial Study was prepared for the proposed project consistent with CEQA, Initial Study No. 2017-17 disclosed the proposed project has no new effects that could occur, and is consistent with the development on the site anticipated by, and addressed within the scope of the Program Environmental Impact Report (SCH No. 2010041078). The Environmental Impact Report prepared for the City of Visalia General Plan was certified by Resolution No. 2014-37, adopted on October 14, 2014. Therefore, Negative Declaration No. 2017-17 can be adopted for the project.

Annexation No. 2017-01

1. The annexation is consistent with the policies and intent of the General Plan.
2. An initial study was prepared for the annexation and tentative subdivision map consistent with CEQA. Initial Study No. 2017-10 disclosed that environmental impacts are determined to be not significant and that the Planning Commission recommends that the City Council adopt Negative Declaration No. 2017-10 for Annexation No. 2017-01.
3. The annexation properties are not in a Land Conservation Contract.

RECOMMENDED CONDITIONS OF APPROVAL

Tentative Subdivision Map No. 5559

1. Approval of TSM 5559 shall not become effective unless Annexation No. 2017-01, placing the project site within the corporate limits of the City of Visalia, is approved by the Tulare County Local Agency Formation Commission (LAFCO), and is fully executed to include all conditions contained in the Pre-Annexation Agreement for Annexation No. 2017-01.
2. K Road: The developer shall provide necessary right of way and complete construction of K Road along the full frontage of the project site, including the Remainder parcel. Such right of way and improvements shall be subject to the review and approval of the Community Development Director.
3. The final subdivision map shall be prepared in substantial compliance with Exhibit "A".
4. That the subdivision shall be developed consistent with the comments and conditions of Site Plan Review No. 2016-161, incorporated herein by reference.
5. That prior to the issuance of a building permit on the site, the applicant / developer shall obtain and provide the City with a valid Will Serve Letter from the California Water Service Company.
6. That all other federal and state laws and city codes and ordinances be complied with.

7. That the applicant submit to the City of Visalia a signed receipt and acceptance of conditions from the applicant, stating that they understand and agree to all the conditions of Tentative Subdivision Map No. 5559, prior to the recordation of the final map.

Annexation No. 2017-01

1. Upon annexation, the territory shall be zoned Single-Family Residential, 5,000 square foot minimum (R-1-5), consistent with the pre-zoning designated by the General Plan Land Use Map.
2. That the applicant(s) enter into a Pre-Annexation Agreement with the City which memorializes the required fees, policies, and other conditions applicable to the annexation. The draft Pre-Annexation Agreement is attached herein. The agreement is subject to final approval by the City Council of the City of Visalia.

APPEAL INFORMATION

According to the City of Visalia Zoning Ordinance Section 17.02.145 and Subdivision Ordinance Section 16.28.080, an appeal to the City Council may be submitted within ten days following the date of a decision by the Planning Commission. An appeal with applicable fees shall be in writing and shall be filed with the City Clerk at 220 N. Santa Fe Street, Visalia, CA 93292. The appeal shall specify errors or abuses of discretion by the Planning Commission, or decisions not supported by the evidence in the record. The appeal form can be found on the city's website www.ci.visalia.ca.us or from the City Clerk.

The Planning Commission's action on the Annexation is advisory only, and is automatically forwarded to the City Council for final action.

Attachments:

- Related Plans & Policies
1. Resolution No. 2017-11 (TSM 5559)
Exhibit "A" – Tentative Subdivision Map 5559
 2. Resolution No. 2017-25 (Annexation 2017-01)
Exhibit "A" – Draft Pre-Annexation Agreement
 3. Site Plan Review Comments
 4. Negative Declaration No. 2017-17
 5. General Plan Land Use Map
 6. Zoning Map
 7. Aerial Map

RELATED PLANS AND POLICIES

City of Visalia General Plan Land Use Element

LU-P-19 Ensure that growth occurs in a compact and concentric fashion by implementing the General Plan's phased growth strategy. The General Plan Land Use Diagram establishes three growth rings to accommodate estimated City population for the years 2020 and 2030. The Urban Development Boundary I (UDB I) shares its boundaries with the 2012 city limits. The Urban Development Boundary II (UDB II) defines the urbanizable area within which a full range of urban services will need to be extended in the first phase of anticipated growth with a target buildout population of 178,000. The Urban Growth Boundary (UGB) defines full buildout of the General Plan with a target buildout population of 210,000. Each growth ring enables the City to expand in all four quadrants, reinforcing a concentric growth pattern.

LU-P-20 Allow annexation and development of residential, commercial, and industrial land to occur within the "Tier I" Urban Development Boundary (UDB) at any time, consistent with the City's Land Use Diagram.

LU-P-34 Work with Tulare County and other state and regional agencies, neighboring cities, and private land trust entities to prevent urban development of agricultural land outside of the current growth boundaries and to promote the use of agricultural preserves, where they will promote orderly development and preservation of farming operations within Tulare County. Conduct additional investigation of the efficacy of agricultural conservation easements by engaging local, regional, and state agencies and stakeholders in order to further analyze their ongoing efforts and programs that attempt to mitigate impacts from the conversion of agricultural lands through the use of agricultural conservation easements. Support regional efforts to prevent urban development of agricultural lands, specifically at the county level. Tulare County's General Plan 2030 Update Policy contains two policies (AG-1.6 Conservation Easements and AG-1.18 Farmland Trust and Funding Sources) that discuss establishing and implementing an Agricultural Conservation Easement Program (ACEP). The City supports the implementation of these measures by the County, in which the City may then participate. Such a regional program could include a fee to assist and support agricultural uses, and would be most feasibly and strategically developed on a countywide or other regional basis. In addition to supporting regional efforts to prevent urban development of agricultural lands, the City shall create and adopt a mitigation program to address conversion of Prime Farmland and Farmland of Statewide Importance in Tiers II and III. This mitigation program shall require a 1:1 ratio of agricultural land preserved to agricultural land converted and require agricultural land preserved to be equivalent to agricultural land converted. The mitigation program shall also require that the agricultural land preserved demonstrate adequate water supply and agricultural zoning, and shall be located outside the City UDB, and within the southern San Joaquin Valley. The mitigation program shall, to the extent feasible and practicable, be integrated with the agricultural easement programs adopted by the County and nearby cities. The City's mitigation program shall allow mitigation to be provided by purchase of conservation easement or payment of fee, but shall indicate a preference for purchase of easements. The mitigation program shall require easements to be held by a qualifying entity, such as a local land trust, and require the submission of annual monitoring reports to the City. The mitigation program shall specifically allow exemptions for conversion of agricultural lands in Tier I, or conversion of agricultural lands for agricultural processing uses, agricultural buffers, public facilities, and roadways.

LU-P-50 Provide development standards to ensure that a mix of detached and attached single-family and multi-family housing types can be compatible in a single development. Development standards may include but not be limited to requiring heights, setbacks, and building massing to be in scale with

surrounding uses or to provide a transition in scale and character; and establishing the spacing of curb cuts and location of parking.

City of Visalia Subdivision Ordinance [Title 16 of Visalia Municipal Code]

16.16.030 Tentative subdivision maps.

A. The tentative map shall be prepared by a registered civil engineer or a licensed land surveyor in accord with the provisions of the Subdivision Map Act and this title and shall be filed with the city planner. Such filing shall be prior to the completion of final surveys of streets and lots and before the start of any grading or construction work within the proposed subdivision.

B. A minimum of thirty (30) copies of the tentative map, and accompanying reports and statements shall be submitted to the city planner at the time of filing. Filing of required documents will be deemed official upon written receipt from the city planner. (Ord. 9605 § 32 (part), 1996: prior code § 9100)

16.16.090 Staff reports.

Any report or recommendation on a tentative map by the staff of the commission or council shall be in writing and a copy thereof served on the subdivider at least three days prior to any hearing or action on such map by the commission or council. (Prior code § 9135)

16.16.100 Hearing and notice.

A. The city planning commission shall hold a public hearing on an application for a tentative subdivision map or vesting tentative subdivision map.

B. Notice of a public hearing shall be given not less than ten days or more than thirty (30) days prior to the date of the hearing by mailing a notice of the time and place of the hearing to property owners within three hundred (300) feet of the boundaries of the area proposed for subdivision. (Prior code § 9140)

16.16.110 Commission approval.

Within fifty (50) days after the tentative map has been filed with the city planner or at such later date as may be required to concurrently process the appurtenant environmental impact review documents required by state law and local ordinances, the commission shall report in writing to the subdivider their decision regarding approval, conditional approval, or disapproval of the map and the conditions on which such action is based. (Ord. 9605 § 32 (part), 1996: prior code § 9145)

16.16.120 Council action.

The city council may overrule or modify any ruling or determination of the commission in regard to a tentative map and may make conditional exceptions if special circumstances pertaining to the property involved justify a variance from the provisions of this title. (Prior code § 9150)

16.16.130 Expiration of maps and extensions.

A. Expiration. The approval or conditional approval of a tentative map shall expire twenty-four (24) months from the date the map was approved or conditionally approved.

B. Extension. The person filing the tentative map may request an extension of the tentative map approval or conditional approval by written application to the city planner who shall forward it to the planning commission for action. Such application shall be filed before the approval or conditional approval is due to expire. The application shall state the reasons for requesting the extension.

C. Time Limit on Extensions. An extension or extensions of tentative map approval or conditional approval shall not exceed an aggregate of three years. (Ord. 9605 § 32 (part), 1996: prior code § 9155)

Section 16.28.080 Appeals.

If the applicant is dissatisfied with the decision of the planning commission, he may, within ten days after the decision of the planning commission, appeal in writing to the council for a hearing thereon. Such hearing need not be concluded on the day thus set but may be continued. (Prior code § 9245)

Section 16.28.110 Right-of-way dedications.

A. Pursuant to the Subdivision Map Act, the subdivider shall provide such dedication of right-of-way and/or easements as may be required by the planning commission.

B. The planning commission may, at its discretion, require that offers of dedication or dedication of streets include a waiver of direct access rights to any such streets from any property shown on the final map as abutting thereon, in accord with the provisions of the Subdivision Map Act. (Prior code § 9260)

Municipal Code Chapter 12.16 (Annexations)

12.16.010 Charges for publication.

All petitioners for annexation of uninhabited property to the city may be billed for an amount sufficient to cover all publication, advertising costs and legal fees occurring from the necessary processing of said annexation petitions. (Prior code § 7025)

12.16.020 Responsibility for public improvement installation in annexed areas.

The owners and/or developers of all parcels of land annexed to the city shall be individually and/or jointly responsible for the installation of all necessary sewers, storm drainage facilities, street improvements, bridges, culverts and other public facilities as required by the city for the general public welfare and for proper annexed area development. The city will not participate financially in any such development or public facility construction except where extension of relief sewers incidentally aid annexed area development. (Prior code § 7026)

RESOLUTION NO 2017-11

A RESOLUTION OF THE PLANNING COMMISSION OF THE CITY OF VISALIA APPROVING REIMER TENTATIVE SUBDIVISION MAP NO. 5559: A REQUEST TO SUBDIVIDE 15.2 ACRES INTO 65 LOTS AND A REMAINDER PARCEL FOR RESIDENTIAL DEVELOPMENT. THE PROJECT IS PRE-ZONED R-1-5 (SINGLE-FAMILY RESIDENTIAL, 5,000 SQ.FT. MINIMUM LOT SIZE), AND IS LOCATED ON THE SOUTH SIDE OF K ROAD, APPROXIMATELY 230 FEET EAST OF BURKE ROAD. (APNS 123-090-008 -014, AND 123-100-004).

WHEREAS, Reimer Tentative Subdivision Map No. 5559 is a request to subdivide 15.2 acres into a 65 lots and a Remainder parcel. The project is pre-zoned R-1-5 (Single Family Residential, 5,000 sq.ft. Minimum Lot Size), and is located on the south side of K Road, approximately 230 feet east of Burke Road. (APNs 123-090-008 -014, and 123-100-004); and

WHEREAS, the Planning Commission of the City of Visalia, after duly published notice held a public hearing before said Commission on April 24, 2017; and

WHEREAS, the Planning Commission of the City of Visalia finds the tentative subdivision map in accordance with Section 16.16 of the Subdivision Ordinance of the City of Visalia, based on the evidence contained in the staff report and testimony presented at the public hearing; and

WHEREAS, the Planning Commission finds that Initial Study No. 2017-17 has identified that the proposed project has no new effects that could occur that have not been addressed within the scope of the Program Environmental Impact Report (SCH No. 2010041078). The Environmental Impact Report prepared for the City of Visalia General Plan was certified by Resolution No. 2014-37, adopted on October 14, 2014.

NOW, THEREFORE, BE IT FURTHER RESOLVED that the Planning Commission of the City of Visalia approves the proposed tentative subdivision map based on the following specific findings and based on the evidence presented:

1. That the proposed location and layout of the Reimer Tentative Subdivision Map No. 5559, its improvement and design, and the conditions under which it will be maintained is consistent with the policies and intent of the General Plan, Zoning Ordinance, and Subdivision Ordinance. The 15.2-acre project site, which is the site of the proposed 65-lot residential subdivision, with a remainder parcels is specifically consistent with General Plan Land Use policies LU-P-19 and LU-P45 related to efficient land use absorption.
2. That the proposed Reimer Tentative Subdivision Map No. 5559, its improvement and design, and the conditions under which it will be maintained will not be detrimental to the public health, safety, or welfare, nor materially injurious to properties or improvements in the vicinity, nor is it likely to cause serious public health problems.

ATTACHMENT 1

That the proposed tentative subdivision map would be compatible with adjacent land uses. The project site is bordered by existing urban roads and development to the north, south and west.

3. That the site is physically suitable for the proposed tentative subdivision map. The Reimer Tentative Subdivision Map No. 5559 is consistent with the intent of the General Plan, Subdivision Ordinance, and Zoning Ordinance, and is not detrimental to the public health, safety, or welfare or materially injurious to properties or improvements in the vicinity. The 65-lot subdivision is designed to comply with the City's Engineering Improvement Standards. This includes a second point of access to the subdivision and extension of a local road within TSM 5559 to connect with K Road.
4. That the site is physically suitable for the proposed tentative subdivision map and the project's density, which is consistent with the underlying Low Density Residential General Plan Land Use Designations. The proposed location and layout of the Reimer Tentative Subdivision Map No. 5559, its improvement and design, and the conditions under which it will be maintained is consistent with the policies and intent of the General Plan, Zoning Ordinance, and Subdivision Ordinance.
5. That the Reimer Tentative Subdivision Map No. 5559 design of the subdivision or the type of improvements will not conflict with easements, acquired by the public at large, for access through or use of, property within the proposed subdivision. The 65-lot subdivision and Remainder parcel is designed to comply with the City's Engineering Improvement Standards.
6. That an Initial Study was prepared for the proposed project consistent with CEQA, Initial Study No. 2017-17 disclosed the proposed project has no new effects that could occur, and is consistent with the development on the site anticipated by, and addressed within the scope of the Program Environmental Impact Report (SCH No. 2010041078). The Environmental Impact Report prepared for the City of Visalia General Plan was certified by Resolution No. 2014-37, adopted on October 14, 2014. Therefore, Negative Declaration No. 2017-17 can be adopted for the project.

BE IT FURTHER RESOLVED that the Planning Commission hereby approves the tentative subdivision map on the real property herein above described in accordance with the terms of this resolution under the provisions of Section 16.16.030 of the Ordinance Code of the City of Visalia, subject to the following conditions:

1. Approval of TSM 5559 shall not become effective unless Annexation No. 2017-01, placing the project site within the corporate limits of the City of Visalia, is approved by the Tulare County Local Agency Formation Commission (LAFCO), and is fully executed to include all conditions contained in the Pre-Annexation Agreement for Annexation No. 2017-01.
2. K Road: The developer shall provide necessary right of way and complete construction of K Road along the full frontage of the project site, including the Remainder parcel. Such right of way and improvements shall be subject to the review and approval of the Community Development Director.

3. The final subdivision map shall be prepared in substantial compliance with Exhibit "A".
4. That the subdivision shall be developed consistent with the comments and conditions of Site Plan Review No. 2016-161, incorporated herein by reference.
5. That prior to the issuance of a building permit on the site, the applicant / developer shall obtain and provide the City with a valid Will Serve Letter from the California Water Service Company.
6. That all other federal and state laws and city codes and ordinances be complied with.

RESOLUTION NO. 2017-25

A RESOLUTION BY THE PLANNING COMMISSION OF THE CITY OF VISALIA RECOMMENDING APPROVAL OF ANNEXATION NO. 2017-01, A REQUEST TO ANNEX THREE PARCELS TOTALING 15.2 ACRES INTO THE CITY LIMITS OF VISALIA, AND TO DETACH FROM TULARE COUNTY SERVICE AREA NO.1. UPON ANNEXATION, THE SITE WOULD BE ZONED R-1-5 (SINGLE-FAMILY RESIDENTIAL, 5,000 SQ.FT. MINIMUM LOT SIZE), WHICH IS CONSISTENT WITH THE GENERAL PLAN LAND USE DESIGNATION OF LOW DENSITY RESIDENTIAL. THE SITE IS LOCATED ON THE SOUTH SIDE OF K ROAD, APPROXIMATELY 230 FEET EAST OF BURKE ROAD (APNS 123- 090-008, -014, AND 123-100-004).

WHEREAS, the project proponents desire to initiate proceedings for annexation to said city of territory described on the attached legal description; and

WHEREAS, the Planning Commission of the City of Visalia, after a duly published notice, did hold a noticed public hearing on April 24, 2017, and

WHEREAS, the proponent desires to annex said territory to the City of Visalia for the following reasons: The annexation will contribute to and facilitate orderly growth and development of both the City and the territory proposed to be annexed; will facilitate and contribute to the proper and orderly layout, design and construction of streets, gutters, sanitary and storm sewers and drainage facilities, both within the City and within the territory proposed to be annexed; and will provide and facilitate proper overall planning and zoning of lands and subdivision of lands in said City and said territory in a manner most conducive of the welfare of said City and said territory; and

WHEREAS, this proposal is made pursuant to the Cortese-Knox-Hertzburg Local Government Reorganization Act of 2000, commencing with Section 56000 of the Government Code of the State of California; and

WHEREAS, the territory proposed to be annexed is uninhabited; and

WHEREAS, the Planning Commission reviewed this proposal on April 24, 2017, and found it to be consistent with the General Plan; and

WHEREAS, the Planning Commission hereby makes the following findings with regard to the project:

1. The annexation is consistent with the policies and intent of the General Plan.
2. An initial study was prepared for the annexation and tentative subdivision map consistent with CEQA. Initial Study No. 2017-17 disclosed that environmental impacts are determined to be not significant and that the Planning Commission recommends that the City Council adopt Negative Declaration No. 2017-17 for Annexation No. 2017-01.

3. The annexation properties are not in a Land Conservation Contract.

BE IT FURTHER RESOLVED that the Planning Commission of the City of Visalia recommends the following actions:

1. Upon annexation, the territory shall be zoned Single-Family Residential, 5,000 square foot minimum (R-1-5), consistent with the pre-zoning designated by the General Plan Land Use Map.
2. That the applicant(s) enter into a Pre-Annexation Agreement with the City which memorializes the required fees, policies, and other conditions applicable to the annexation. The draft Pre-Annexation Agreement is attached herein as Exhibit "A". The agreement is subject to final approval by the City Council of the City of Visalia.

EXHIBIT A
DRAFT
4-24-17

Pre-Annexation Agreement

This Pre-Annexation Agreement ("Agreement") is made and entered into this ____ day of _____, by and among the City of Visalia, a charter law city ("City") and Presidio JJR Chelsea West, LLC (hereinafter "Owner"):

RECITALS

WHEREAS, Owners are the record owners of the property, currently located in the unincorporated area of the County of Tulare, legally described in Exhibit A and depicted in Exhibit B, which are attached hereto and incorporated herein by reference (hereinafter referred to as the "Property"); and

WHEREAS, the Property is adjacent to and contiguous to the existing corporate boundary of the City, but is not situated within the limits of any municipality; and

WHEREAS, Owner desires to have the Property annexed to the City and to have the Property zoned as R-1-5, which would permit the Property to be used for Low Density Residential; and

WHEREAS, the Property consists of approximately 15.2 acres, and no electors reside thereon; and

WHEREAS, proper applications have been filed with the City for approval of the annexation, rezoning, and conditional uses as may be required for the Property; and

WHEREAS, the City has, by a resolution requesting initiation of proceedings to annex territory ("Resolution") adopted on TBD, initiated proceedings to annex the Property; and

WHEREAS, in certain annexation proceedings Williamson Act issues arise which require indemnification of LAFCO, in said event, City requires indemnification from Developer; and

WHEREAS, finding X of Resolution No. 2017-XX initiating annexation requires entry into this Annexation Agreement prior to the City submitting an application to the Local Area Formation Commission to commence the proposed annexation; and

WHEREAS, Owner acknowledges that during the term of this Agreement the Property will be subject to all ordinances, resolutions, and other regulations of the City, as they may be amended from time to time, as well as state and federal statutes and regulations, as they may be amended.

WHEREAS, the City is authorized by its police powers to protect the health, safety and welfare of the community, and is entering into this Agreement and executing such authority for said purpose; and

WHEREAS, nothing contained in this Agreement shall constitute a waiver of the City's legislative, governmental, or police powers to promote and protect the health, safety and welfare of the City and its inhabitants, nor shall this Agreement prohibit the enactment or increase by town of any tax, fee, or charge.

NOW, THEREFORE, in consideration of the above Recitals and the following Covenants, it is agreed by and between the parties as follows:

I. AGREEMENT

- A. Parties. The parties to this Agreement are the City and Owner.
- B. Incorporation of Recitals. The parties confirm and incorporate the foregoing Recitals into this Agreement.
- C. Purpose/Limits of Agreement. A specific purpose of this Agreement is to set forth specific terms and conditions of annexation of the Property to City.

II. TERMS AND CONDITIONS OF ANNEXATION; PURPOSE OF AGREEMENT

Generally, each party to this Agreement is benefited and burdened by detachment from the County and annexation to the City. Owner will obtain a variety of services from City and City will obtain additional tax revenues. City has adopted ordinances, regulations, and policies concerning design, improvement, construction, development and use of property within the City. Nothing contained in this Agreement shall constitute a waiver of City's legislative, governmental, or police powers to promote and protect the health, safety, and welfare of City and its inhabitants, nor shall this Agreement prohibit the enactment or increase by City of any tax or fee. The purpose of this Agreement is to spell out additional conditions to which Owner will be subject following annexation and prior to development within the City due to the burden placed on City by Owner's desired annexation:

- A. Water Acquisition Policy: Although City's current water service provider, California Water Service, continues to issue will-serve letters, City's Council is aware of the steadily decreasing level of water in the City's underground water aquifers and has determined that increasing development is contributing to this serious problem. Therefore, City's

Council has studied the issue and investigated possible solutions in order that it may continue to assure citizens that there will be water available to serve the community's needs. City's Council is actively engaged in water replenishment activities with the Kaweah Delta Water Conservation District and it has adopted a policy, as set forth in Chapter 16.54 of the Visalia Municipal Code, which requires annexation applicants to convey title to water rights to City upon annexation and/or to pay a fee to City (pursuant to an adopted fee schedule) so that City may acquire water for groundwater replenishment and storage in order to serve new development that comes with annexation, including development of the Property (the "Water Acquisition Policy"). Therefore, Owner agrees that, at the time that LAFCO issues a Certificate of Completion finalizing the annexation (and upon the running of all applicable statutes of limitation related thereto), Owner will comply with the Water Acquisition Policy by entering into an agreement with City to either (i) convey to City those water rights vested in the Property, if any, (ii) agree to pay City a fee in lieu thereof, (iii) agree to some combination of an in lieu fee payment and water right conveyance, or (iv) to comply by any other method allowed by the Water Acquisition Policy, provided that such agreement includes a condition precedent requiring City's water supplier to agree to serve the Property with potable water in amount sufficient to meet Owner's reasonably anticipated total water demand for the Property, as determined by a valid water supply assessment prepared pursuant to California Water Code § 10910 *et seq.* No post-annexation permit or entitlement approvals concerning the Property will be issued by City unless and until Owner complies with the Water Acquisition Policy in a manner consistent with this subsection II(A). Owner agrees that it shall identify all water rights which, to the best of Owner's knowledge, have been used by Owner or its agents in connection with the Property, regardless of whether they are considered "vested" in the Property, and shall comply with the Water Acquisition Policy by entering into an agreement with City to convey such rights, if any, to City. City shall cooperate with Owner in valuing such water rights for the purposes of determining the amount of offset to be applied against the in lieu fee as required pursuant of the Water Acquisition Policy. Owner further agrees that City shall have first right of refusal in acquiring upon mutually acceptable terms any water rights that Owner owns that may be in addition to those required to meet Owner's obligations under the Water Acquisition Policy. City agrees that water rights need not be conveyed and in lieu fees shall not be made payable until City's issuance of one or more parcel maps or final subdivision maps covering the Property and, in the event Owner applies to City for its approval of multiple final maps covering the Property, City agrees such water rights conveyance or fee payment obligation shall be allocated on a pro rata basis to each phase of development covered by each final subdivision map, with conveyance of water rights or payment to be made on a per map basis upon City's issuance of each final subdivision map covering the Property.

- B. General Plan Maintenance Fee: On June 21, 2004, the City adopted (by Resolution 2004-63, as corrected) a General Plan Maintenance Fee.

Owner agrees that, at the time LAFCO issues a Certificate of Completion finalizing the annexation (and upon the running of all applicable statutes of limitation related thereto), Owner will enter into an agreement with City to pay the General Plan Maintenance Fee in an amount equal to \$374 per acre and no post-annexation permit or entitlement approvals concerning the Property will be issued unless and until said agreement is executed. City agrees that such fee shall not be made payable until City's issuance of one or more final subdivision maps covering the Property and, in the event Owner applies to City for its approval of multiple final maps covering the Property, City agrees such fee payment obligation shall be allocated on a pro rata basis to each phase of development covered by each final subdivision map, with payment to be made on a per map basis upon City's issuance of each final subdivision map covering the Property. Owner's satisfaction of its obligations under this Section II(B) will satisfy any and all of Owner's obligations related to and arising under the General Plan Maintenance Fee.

C. ~~Williamson Act:~~

~~C 1: Indemnification: Occasionally property to be annexed is burdened with contract(s) entered into pursuant to the Williamson Act which the City may succeed to and administer if the annexation is completed. In some events, the owners of land subject to a Williamson Act contract desire to cancel said contract(s). Specific statutory findings must be made in order to cancel said contract, as required by the Williamson Act. In the event of an Owner initiated request for cancellation of Williamson Act contracts which burden land subject to this Agreement, Owner agrees to concurrently enter into an agreement to indemnify, hold harmless, and defend (with counsel of City's choosing), the City, its officers, elected officials, employees, and agents, from and against any and all third party claims, demands, or damages arising from its decision with respect to such cancellation request regardless of the date the cancellation request is made or initiated. The indemnification agreement contemplated by this Section II(C) shall also provide that Owner may, to the extent permitted by law, participate in any legal proceedings contemplated by this Section II(C) as a real party in interest, with legal counsel of Owner's choosing.~~

~~C 2: Option Not To Succeed To A Williamson Act Contract. On _____, City filed with LAFCO a formal protest of Williamson Act Contract Preserve No. _____ (Contract No. _____). On _____, LAFCO formally upheld City's protest of Williamson Act Contract Preserve No. _____ (Contract No. _____), specifically finding that such contract is inconsistent with the publicly desirable future use and control of the land burdened thereby. If City determines to apply to LAFCO for the annexation of the Property, City agrees to take any and all steps necessary to preserve and exercise its option not to succeed to~~

~~Williamson Act Contract Preserve No. _____ (Contract No. _____), as provided by Government Code § 51243.5.~~

~~C 3: Agricultural Easement Exchange. In the event of an Owner-initiated request for cancellation of Williamson Act contracts which burden land subject to this Agreement, City agrees to consider (and the parties agree to cooperate to facilitate) a potential agricultural easement exchange, as contemplated by the Williamson Act's agricultural easement exchange program set forth in Government Code § 51256. If, following appropriate environmental review pursuant to CEQA, City determines to pursue an agricultural easement exchange with respect to any portion of the Property, Owner and City would enter into an agreement to rescind the relevant Williamson Act contract(s) in accordance with the Williamson Act's cancellation provisions (i.e., Government Code § 51282) in order to simultaneously place other land under an agricultural conservation easement in perpetuity, provided such exchange is first approved by the Department of Conservation. Per the requirements of the easement exchange program, the value of the proposed agricultural conservation easement shall be at least equal to the cancellation fee that Owner would otherwise pay if the subject Williamson Act contract(s) were canceled pursuant to the Williamson Act's standard cancellation procedures. If a willing seller of an agricultural easement cannot be identified, then, per the agreement contemplated by this subsection II(H), Owner would pay the standard cancellation fee in accordance with the Williamson Act's cancellation procedures. In the alternative, the agreement contemplated by this subsection II(H) shall permit Owner to maintain the existing Williamson Act contracts for the remainder of their term.~~

- D. Plan For Providing Services. The parties agree to cooperate in, and to take such actions as may be necessary to ensure, the diligent preparation of a Plan For Providing Services to the Property, to be submitted to LAFCO along with City's annexation application, in accordance with Cortese-Knox-Hertzberg Act requirements.

Developer understands and agrees that building permits and other entitlements for development on the Property will not be issued unless and until each and every condition herein is met.

III. TERM

The term of this Agreement shall become effective when fully executed by the parties hereto (the "Effective Date") and continue for a period of twenty (20) years. This Agreement shall terminate if (a) the annexation proceedings are terminated for any reason; or (b) the completion of the annexation (recording of a Certificate of Completion) does not occur on or before one (1) year from the Effective Date. Any indemnification provision included herewith shall survive termination and continue until expiration of the statute of limitations applicable to the subject matter thereof.

IV. DEFAULT, REMEDIES AND ENFORCEMENT

In the event of breach or default of any term, condition, covenant or obligation of this Agreement by either party, the other party may exercise any rights available at law or in equity, including an action for specific performance or other injunctive relief, and all such remedies shall be cumulative. This Agreement shall be enforceable, unless lawfully terminated or cancelled, by any party to the Agreement or any party's successor in interest, notwithstanding any subsequent changes in any applicable law adopted by the City which alters or amends the laws, ordinances, resolutions, rules or policies frozen by this Agreement.

V. INDEMNIFICATION

Owner agrees to indemnify and hold harmless City and the City's officers, employees, agents, and contractors, from and against all liability, claims, causes of actions, and demands, including attorney's fees and court costs, which arise out of or are in any manner connected with this Agreement or its operation, or with any other action annexation or other action determined necessary or desirable by the City in order to effectuate the annexation of Owner's property, or which are in any manner connected with the City's enforcement of this Agreement. Owner further agrees to investigate, handle, respond to, and to provide defense for and defend against or at the City's option to pay the attorney's fees and court costs, which arise out of or are in any manner connected with this Agreement or its operation.

VI. MISCELLANEOUS

- a. Binding Effect/Covenants to Run With Land. The Parties hereto agree to be bound by this Agreement. This Agreement shall be binding upon and shall inure to the benefit of the heirs, transferees, successors and assigns of the parties hereto. The terms and conditions stated herein shall constitute covenants running with the land.
- b. Assignment. Neither party shall assign, delegate or transfer their rights and duties in this Agreement without the written consent of the other party.
- c. Authorized Signatory. The individuals executing this Agreement, by their signature hereto, declare that they are authorized to, and have the legal power, right and actual authority to bind the party to the terms and conditions of this Agreement.
- d. Notices. All notices under this Agreement shall be effective upon personal delivery to City, or Owner, as the case may be, three (3) business days after deposit in the United States Mail, postage fully prepaid, addressed to the respective parties as follows:

To the City: City Manager

City of Visalia
220 N. Santa Fe Street
Visalia, CA 93291

With Copy to: **Kenneth J. Richardson**
City Attorney
Peltzer & Richardson
XX Mineral King
Visalia, CA 93291

To Owner: XX

Or such other address as the parties may from time to time designate by giving notice as required hereunder.

- e. Entire Agreement. This Agreement represents the entire agreement between the City and Owner as to its subject matter and no prior oral or written understanding shall be of any force or affect.
- f. Amendment. No part of this Agreement may be modified without the written consent of both parties.
- g. Headings. Section headings are provided for organizational purposes only and do not in any manner affect the scope, meaning, or intent of the provisions under the heading.
- h. No Third Party Beneficiaries Intended. Except as provided herein, the parties of this Agreement do not intend to provide any other party with any benefit or enforceable legal or equitable right or remedy.
- i. Exhibits and Recitals. The recitals and any exhibits to this Agreement are fully incorporated by reference and are integral parts of this Agreement.
- j. Conflict With Laws or Regulations/Severability. This Agreement is subject to all applicable laws and regulations. If any provision(s) of this Agreement is found by any court or other legal authority, or is agreed by the parties, to be in conflict with any code or regulation governing this subject, the conflicting provision(s) shall be considered null and void. If the effect of nullifying any conflicting provision is such that a material benefit of the Agreement to either party is lost, the Agreement may be terminated at the option of the effected party. In all other cases, the remainder of the Agreement shall continue in full force and effect.
- k. Waiver. A waiver of any breach of this Agreement by any party shall not constitute a continuing waiver or a waiver of any subsequent breach of the same or any other provision of this Agreement.

1. Choice of Law - Venue. This Agreement shall be governed by the laws of the State of California and any questions arising hereunder shall be construed or determined according to such law. Venue for any legal action arising from or in connection with this Agreement or the Property shall be in Tulare County, California.

- m. Attorneys Fees. In the event either party commences any action, arbitration or legal proceedings for the enforcement of this Agreement, the prevailing party, as determined by the court or arbitrator, shall be entitled to recovery of its reasonable fees and costs, including attorneys fees, court costs and arbitration costs incurred in the action brought thereon.

- n. No Agency, Joint Venture or Partnership. It is understood that this Agreement is a contract that has been negotiated and voluntarily entered into by City and Owner and that Owner is not an agent of City. City and Owner hereby renounce the existence of any form of joint venture or partnership between them, and agree that nothing contained herein or in any document executed in connection therewith shall be construed as making City and Owner joint venturers or partners.

- o. Excusable Delays; Extension of Time of Performance. In the event of delays due to strikes, inability to obtain materials, civil commotion, fire, war, terrorism, lockouts, third-party litigation or other legal challenges regarding the annexation, riots, floods, earthquakes, epidemic, quarantine, freight embargoes, failure of contractors to perform, or other circumstances beyond the reasonable control of the parties and which cause substantially interferes with the ability of either party to perform its obligations under this Agreement, then the time for performance of any such obligation shall be extended for such period of time as the cause of such delay shall exist but in any event not longer than for such period of time.

- p. Further Assurances. The parties will execute and deliver, upon demand by the other party, such further documents, instruments and conveyances, and shall take such further actions as such other party may request from time to time to document the transactions set forth herein.

- q. Recordation of Agreement; Counterparts. This Agreement, or an abstract of its material terms and conditions shall be recorded by either party in the Official Records of the Tulare County Recorder. This Agreement may be executed in counterparts and, when all counterparts are combined, shall constitute a single agreement.

////

IN WITNESS WHEREOF, the parties have executed this Agreement on the date set forth next to their signature.

CITY

Date: _____

By: _____
Mike Olmos, City Manager

Attest:

Date: _____

By: _____
Michelle Nicholson, City Clerk

Approved as to Form:

Date: _____

By: _____
Kenneth J. Richardson,
City Attorney

OWNER

Date: _____

By: _____

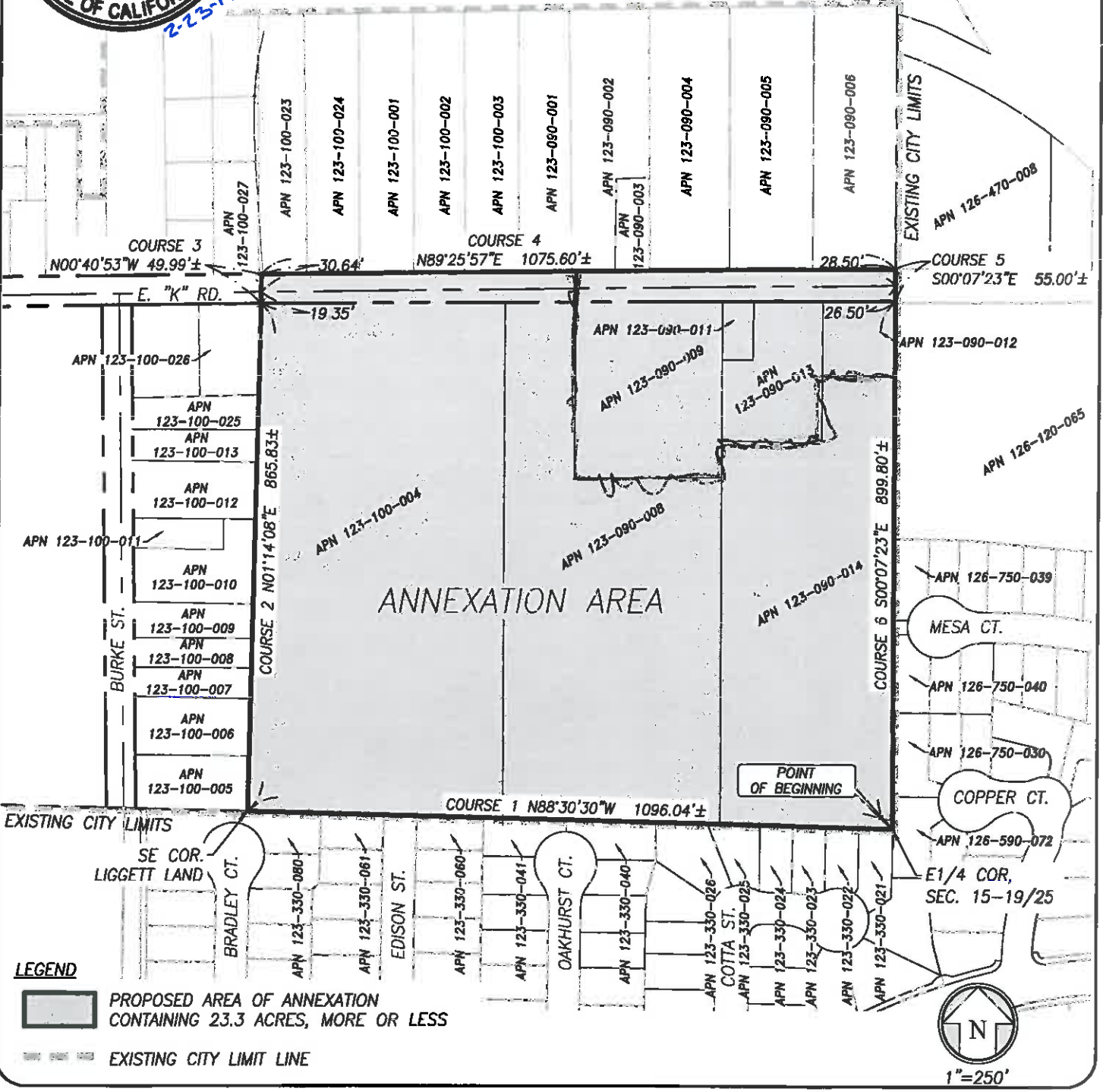

L:\PROJECTS\2015\150156\ACAD\EXHIBITS\150156 ANNEXATION EXHIBIT.DWG 2/23/2017 4:33 PM

LEGEND

- PROPOSED AREA OF ANNEXATION CONTAINING 23.3 ACRES, MORE OR LESS
- EXISTING CITY LIMIT LINE



PROJECT NO.: 150156
DRAWN BY: JLC
CHECKED BY: DCK
SCALE: 1"=250'
SHEET NO.: 1 OF 1

MERCED JJR, LLC
 222 N. GARDEN STREET
 VISALIA, CA 93291
 (559) 732-2660

"EXHIBIT B"
CITY OF VISALIA ANNEXATION
 APPLICATION NO. _____

901 EAST MAIN STREET TEL: (559) 733-0440
 VISALIA, CA 93292 WWW.QKINC.COM
© COPYRIGHT BY QUAD KNOPF, INC. UNAUTHORIZED USE PROHIBITED.

“Exhibit A”

Application No. ____ - ____

“K” Road Annexation

DESCRIPTION

That portion of the Southeast quarter, of the Northeast quarter of Section 5, Township 19 South, Range 25 East, Mount Diablo Base and Meridian, in the County of Tulare, State of California, more particularly described as follows;

Beginning at the Southeast corner of said Northeast quarter corner of Section 5, said point being situated on the existing City Limits Line of the City of Visalia;

Course 1: Thence, North 88°30'30" West, along the South line of said Northeast quarter, and along said City Limits Line, 1096.04 feet, more or less, to the Southeast corner of property conveyed to Ada J. Liggett per Indenture dated April 24, 1918, and recorded in Book 263, of Deeds, at Page 154, Tulare County Records;

Course 2: Thence, leaving said City Limits Line, North 1°14'08" East, along the East line of said Liggett property, 865.83 feet, more or less, to the South line of the County road to Farmersville, also known as “K” Road;

Course 3: Thence, at right angles to the centerline of said “K” Road, North 0°40'53" West, 49.99 feet more or less, to a point situated on the North right-of-way line of “K” Road;

Course 4: Thence, North 89°25'57" East, along said North right-of-way line, 1075.60 feet, more or less, to a point situated on the East line of said Northeast quarter of Section 5, and which point is situated on said existing City Limits Line;

Course 5: Thence, South 00°07'23" East, along last said East line, and along said existing City Limits Line, 55.00 feet, more or less, to a point situated on said South right-of-way line of “K” Road;

Course 6: Thence, continuing along the last said East line, and continuing along said existing City Limits Line, South 00°07'23" East, 899.80 feet, more or less, to the Point of Beginning.

Containing 23.3 acres, more or less





MEETING DATE November 23, 2016
SITE PLAN NO. 16-161
PARCEL MAP NO.
SUBDIVISION
LOT LINE ADJUSTMENT NO.

Enclosed for your review are the comments and decisions of the Site Plan Review committee. Please review all comments since they may impact your project.

- RESUBMIT** Major changes to your plans are required. Prior to accepting construction drawings for building permit, your project must return to the Site Plan Review Committee for review of the revised plans.
- During site plan design/policy concerns were identified, schedule a meeting with
- Planning Engineering prior to resubmittal plans for Site Plan Review.
- Solid Waste Parks and Recreation Fire Dept.

REVISE AND PROCEED (see below)

- A revised plan addressing the Committee comments and revisions must be submitted for Off-Agenda Review and approval prior to submitting for building permits or discretionary actions.
- Submit plans for a building permit between the hours of 9:00 a.m. and 4:00 p.m., Monday through Friday.
- Your plans must be reviewed by:
- CITY COUNCIL REDEVELOPMENT
 PLANNING COMMISSION PARK/RECREATION
 Tentitive Subdivision Map
 HISTORIC PRESERVATION OTHER -

ADDITIONAL COMMENTS: LAFCO

If you have any questions or comments, please call Jason Huckleberry at (559) 713-4259.2
Site Plan Review Committee

ATTACHMENT 3



Site Plan Review Comments For:

Visalia Fire Department
Kurtis A. Brown,
Fire Marshal
707 W Acequia
Visalia, CA 93291
559-713-4261 *office*
559-713-4808 *fax*

ITEM NO: 5

DATE: November 23, 2016

SITE PLAN NO:

SPR16161 **RESUBMIT**

PROJECT TITLE:

REIMER PROPERTY TENTATIVE SUBDIVISION MAP

DESCRIPTION:

63 LOT RESIDENTIAL SUBDIVISION (X) (X)

APPLICANT:

FREEMAN RICH

PROP OWNER:

BIEHLE DIANE R(TR)(DR SURV TR)

LOCATION:

BURKE & K ROAD, APNS:123-100-004, 123-090-008,

APN(S):

123-090-008

The following comments are applicable when checked:

- The Site Plan Review comments are issued as general overview of your project. With further details, additional requirements will be enforced at the Plan Review stage. Please refer to the 2013 California Fire Code (CFC), 2013 California Building Codes (CBC) and City of Visalia Municipal Codes.
- All fire detection, alarm, and extinguishing systems in existing buildings shall be maintained in an operative condition at all times and shall be replaced or repaired where defective. If building has been vacant for a significant amount of time, the fire detection, alarm, and or extinguishing systems may need to be evaluated by a licensed professional. *2013 CFC 901.6*
- No fire protection items required for parcel map or lot line adjustment; however, any future projects will be subject to fire & life safety requirements including fire protection.
- More information is needed before a Site Plan Review can be conducted. Please submit plans with more detail. Please include information on

General:

- Address numbers must be placed on the exterior of the building in such a position as to be clearly and plainly visible from the street. Numbers will be at least four inches (4") high and shall be of a color to contrast with their background. If multiple addresses served are by a common driveway, the range of numbers shall be posted at the roadway/driveway. *2013 CFC 505.1*
- A Knox Box key lock system is required. Where access to or within a structure or an area is restricted because of secured openings (doors and/or gates) or for fire-fighting purposes, a key box is to be installed in an approved location. (Note: Knox boxes shall be ordered using an approved application that can be found at Fire Administration Office located at 707 W. Acequia Ave. Please allow adequate time for shipping and installation.) *2013 CFC 506.1*
- All hardware on exit doors shall comply with Chapter 10 of the 2013 California Fire Code. This includes all locks, latches, dolt locks, and panic and fire exit hardware.
- Provide Illuminated exit signs and emergency lighting through-out building. *2013 CFC 1011*
- When portion of the building are built upon a property line or in close proximity to another structure the exterior wall shall be constructed as to comply *2013 California Building Code Table 508.4 and Table 602.*

- Commercial dumpsters with 1.5 cubic yards or more shall not be stored or placed within 5 feet of combustible walls, openings, or a combustible roof eave line except when protected by a fire sprinkler system. *2013 CFC 304.3.3*
- If your business handles hazardous material in amounts that exceed the Maximum Allowable Quantities listed on *Table 5003.1.1(1), 5003.1.1(2), 5003.1.1(3) and 5003.1.1(4) of the 2013 California Fire Code*, you are required to submit an emergency response plan to the Tulare County Health Department. Also you shall indicate the quantities on your building plans and prior to the building final inspection a copy of your emergency response plan and Safety Data Sheets shall be submitted to the Visalia Fire Department.

Water Supply:

- Construction and demolition sites shall have an approved water supply for fire protection, either temporary or permanent, and shall be made available as soon as combustible material arrives on the site. *2013 CFC 3312*
- No additional fire hydrants are required for this project; however, additional fire hydrants may be required for any future development.
- There is/are fire hydrants required for this project. (See marked plans for fire hydrant locations.)
- Fire hydrant spacing shall comply with the following requirements:
The exact location of fire hydrants and final decision as to the number of fire hydrants shall be at the discretion of the fire marshal, fire chief and/or their designee. *Visalia Municipal Code 16.36.120 & 16.36.120(8)*
- Single-family residential developments shall be provided with fire hydrants every six hundred (600) lineal feet of residential frontage. In isolated developments, no less than two (2) fire hydrants shall be provided.
- Multi-family, zero lot line clearance, mobile home park or condominium developments shall be provided with fire hydrants every four hundred (400) lineal feet of frontage. In isolated developments, no less than two (2) fire hydrants shall be provided.
- Multi-family or condominium developments with one hundred (100) percent coverage fire sprinkler systems shall be provided with fire hydrants every six (600) lineal feet of frontage. In isolated developments, no less than two (2) fire hydrants shall be provided.
- Commercial or industrial developments shall be provided with fire hydrants every three hundred (300) lineal feet of frontage. In isolated developments, no less than two (2) fire hydrants shall be provided.
- Commercial or industrial developments with one hundred (100) percent coverage fire sprinkler systems shall be provided with fire hydrants every five hundred (500) lineal feet of frontage. In isolated developments, no less than two (2) fire hydrants shall be provided.
- When any portion of a building is in excess of one hundred fifty (150) feet from a water supply on a public street there shall be provided on site fire hydrants and water mains capable of supplying the required fire flow. *Visalia Municipal Code 16.36.120(6)*

Emergency Access:

- A construction access road is required and shall be a minimum of 20 feet wide. The road shall be an all-weather driving surface accessible prior to and during construction. The access road shall be capable of holding 75,000 pound piece of fire apparatus, and shall provide access to within 100 feet of temporary or permanent fire department connections. *2013 CFC 3310*

- Buildings or portions of buildings or facilities with a vertical distance between the grade plans and the highest roof surface exceed 30 feet shall provide an approved fire apparatus access roads capable of accommodating fire department aerial apparatus. Access roads shall have a minimum unobstructed width of 26 feet, exclusive of shoulders. Access routes shall be located within a minimum of 15 feet and maximum of 30 feet from the building, and shall be positioned parallel to one entire side of the building. *2013 CFC D105*

- A fire apparatus access roads shall be provide and must comply with the CFC and extend to within 150 of all portions of the facility and all portions of the exterior walls of the first story of the building as measured by an approved route around the exterior of the building or facility. Minimum turning radius for emergency fire apparatus shall be 20 feet inside radius and 43 feet outside radius. *2013 CFC 503.1.1*

- Fire apparatus access roads in excess of 150 feet and dead end shall be provided with a turnaround. Length 151-500 feet shall be a minimum of 20 feet in width and have a 120 foot Hammerhead, 60-foot "Y" or 96-Foot diameter Cul-de-sac in accordance with Figure D103.1 of the 2013 CFC. Length 501-750 feet shall be 26 feet in width and have a 120 foot Hammerhead, 60-foot "Y" or 96-Foot diameter Cul-de-sac in accordance with Figure D103.1 of the 2013 CFC.

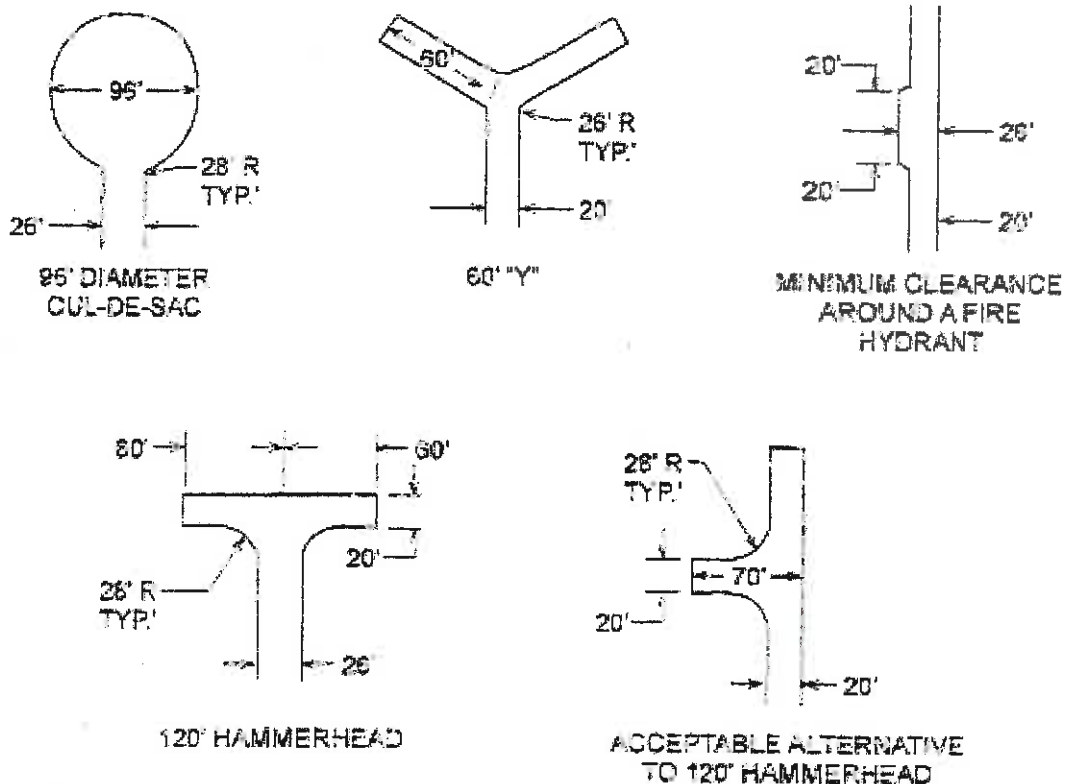

FIGURE D103.1
DEAD-END FIRE APPARATUS ACCESS ROAD TURNAROUND

Gates on access roads shall be a minimum width of 20 feet and shall comply with the following:
2013 CFC D103.5

- Typical chain and lock shall be the type that can be cut with a common bolt cutter, or the developer may opt to provide a Knox Box key lock system.
- Gates shall be of the swinging or sliding type.
- Gates shall allow manual operation by one person. (power outages)
- Gates shall be maintained in an operative condition at all times.
- Electric gates shall be equipped with a means of opening the gate by fire department personnel for emergency access. (Note: Knox boxes shall be ordered using an approved application that can be found at Fire Administration Office located at 707 W. Acequia Ave. Please allow adequate time for shipping and installation.)

In any and all new One- or two-family dwellings residential developments regardless of the number of units, street width shall be a minimum of 36 feet from curb to curb to allow fire department access and to permit parking on both sides of the street. A minimum of 20 feet shall be provided for developments that don't allow parking on the streets. *2013 CFC D107.2*

Fire Protection Systems:

An automatic fire sprinkler system will be required for this building. Also a fire hydrant is required within 50 feet of the Fire Department Connection (FDC). *2013 CFC 903 and Visalia Municipal Code 16.36.120(7)*

Commercial cooking appliances and domestic cooking appliances used for commercial purposes that produces grease laden vapors shall be provided with a Type 1 Hood, in accordance with the California Mechanical Code, and an automatic fire extinguishing system. *2013 CFC 904.11 & 609.2*

Special Comments:

Kurtis A. Brown
Fire Marshal

City of Visalia
Police Department
303 S. Johnson St.
Visalia, Ca. 93292
(559) 713-4370

ITEM NO: 5 DATE: November 23, 2016
SITE PLAN NO: SPR16161 **RESUBMIT**
PROJECT TITLE: REIMER PROPERTY TENTATIVE SUBDIVISION MAP
DESCRIPTION: 63 LOT RESIDENTIAL SUBDIVISION (X) (X)
APPLICANT: FREEMAN RICH
PROP OWNER: BIEHLE DIANE R(TR)(DR SURV TR)
LOCATION: BURKE & K ROAD, APNS:123-100-004, 123-090-008,
APN(S): 123-090-006

Site Plan Review Comments

- No Comment at this time.
- Request opportunity to comment or make recommendations as to safety issues as plans are developed.
- Public Safety Impact fee:
Ordinance No. 2001-11 Chapter 16.48 of Title 16 of the Visalia Municipal Code
Effective date - August 17, 2001

Impact fees shall be imposed by the City pursuant to this Ordinance as a condition of or in conjunction with the approval of a development project. "New Development or Development Project" means any new building, structure or improvement of any parcels of land, upon which no like building, structure of improvement previously existed. *Refer to Engineering Site Plan comments for fee estimation.
- Not enough information provided. Please provide additional information pertaining to:

- Territorial Reinforcement: Define property lines (private/public space).

- Access Controlled / Restricted etc:

- Lighting Concerns:

- Landscaping Concerns:

- Traffic Concerns:

- Surveillance Issues:

- Line of Sight Issues:

- Other Concerns:



Visalia Police Department

SITE PLAN REVIEW COMMENTS

Paul Bernal, Planning Division (559) 713-4025

Date: November 23, 2016

SITE PLAN NO: 2016-161 RESUBMITTAL
PROJECT TITLE: REIMER PROPERTY TENTATIVE SUBDIVISION MAP
DESCRIPTION: 63 LOT RESIDENTIAL SUBDIVISION (X) (X)
APPLICANT: FREEMAN RICH
PROP. OWNER: BIEHLE DIANE R(TR)(DR SURV TR)
LOCATION TITLE: BURKE & K ROAD, APNS:123-100-004, 123-090-008, 123-090-014
APN TITLE: 123-090-008
GENERAL PLAN: Low Density Residential
EXISTING ZONING: County – If annexed to City R-1-6 (Single-Family Residential 6,000 sq. ft. min)

Planning Division Recommendation:

- Revise and Proceed
 Resubmit

Project Requirements

- Annexation & Pre-Annexation Agreement
- Subdivision Map
- Street connection to K Ave
- Building Permits
- Additional Information as Needed

PROJECT SPECIFIC INFORMATION: 11/26/2016

1. Annexation of the County Island is required. Staff recommends the applicant contact LAFCO staff to discuss the parameters of the annexation, and additional properties that would need to be included in the annexation. Staff's initial recommendation would include those properties east of the proposed north/south local street identified as APNs: 123-090-009, 123-090-011, 123-090-012 and 123-090-013.
2. Staff will require the local street connection to K Ave with the initial development phase for this subdivision.
3. Improvements (curb, gutter, sidewalk) along K Ave and the north/south local street for APN: 123-100-004 will be conditioned as part of the subdivision map improvements.
4. The basin site and house site shall be listed as either a Remainder or Lot of the proposed subdivision.
5. Lots 51 and 52 shall have a minimum lot width of 70 feet.

PREVIOUS COMMENTS

PROJECT SPECIFIC INFORMATION: 10/26/2016

6. Annexation of the County Island is required. Staff recommends the applicant contact LAFCO staff to discuss the parameters of the annexation, and additional properties that would need to be included in the annexation. Staff's initial recommendation would include those properties east of the proposed north/south local street identified as APNs: 123-090-009, 123-090-011, 123-090-012 and 123-090-013.
7. The ponding basin depicted on the subdivision map is not supported by Engineering Staff. Comply with Engineering Division's comments regarding Storm Drainage Master Planning for this subdivision.
8. Staff will require the local street connection to K Ave with the initial development phase for this subdivision.
9. Improvements (curb, gutter, sidewalk) along K Ave and the north/south local street for APN: 123-100-004 will be conditioned as part of the subdivision map improvements.
10. The local east/west street connection with the R-M-2 zoned property east of the subdivision cannot be achieved based on the approved tentative subdivision map approved on the R-M-2 site that does not lend itself to make the connection as depicted. Redesign this street.

11. Corner lots in the R-1-6 zone shall be 70 feet in width.

CITY GENERAL PLAN CONSISTENCY

Staff initial finding is that the proposed site plan IS CONSISTENT with the City General Plan. Because this project requires discretionary approval by the City Council and/or Planning Commission the final determination of consistency will be made by the Planning Commission and/or City Council.

R-1-6 Single Family Residential Zone [17.12]

Maximum Building Height: 35 Feet

Minimum Setbacks:

	Building	Landscaping
➤ Front	15 Feet	15 Feet
➤ Front Garage (garage w/door to street)	22 Feet	22 Feet
➤ Side	5 Feet	5 Feet
➤ Street side on corner lot	10 Feet	10 Feet
➤ Rear	25 Feet*	25 Feet

Minimum Site Area: 6,000 square feet

Accessory Structures:

Maximum Height: 12 feet (as measured from average grade next to the structure)

Maximum Coverage: 20% of required Rear Yard (last 25 feet by the width)

Reverse Corner Lots: No structure in the 25 feet of adjacent lot's front yard area, see Zoning Ordinance Section 17.12.100 for complete standards and requirements.

NOTE: Staff recommendations contained in this document are not to be considered support for a particular action or project unless otherwise stated in the comments. The comments found on this document pertain to the site plan submitted for review on the above referenced date. Any changes made to the plan submitted must be submitted for additional review.

Signature

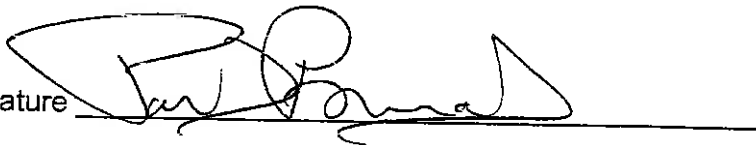

CITY OF VISALIA SITE PLAN REVIEW APPLICATION

RECEIVED
NOV 17 2016
COMM. DEVELOP.
CITY OF VISALIA

- Additional information and help in filling out this application can be found at the City of Visalia website (www.ci.visalia.ca.us) or by calling (559) 713-4440

This application MUST be filled out in its entirety and submitted with an acceptable site plan (see details below). Failure to provide all requested information may result in your application being rejected for additional information and excluded from the Site Plan Review agenda

- All plans to be considered on the next available agenda must be submitted by 4:00 p.m. on the Thursday prior to the meeting

- Site plan review meetings are held on Wednesdays at 9am at City Hall East - 315 E Acequia Ave - Applicant or representative must be present

GENERAL PROJECT INFORMATION

Project/Business Name: CHELSEA WEST Date: 11-17-16

Project Description: CHELSEA WEST TENTATIVE MAP

Site Plan Review Resubmittal: Yes No If Resubmittal, Previous Site Plan Review Number: 16-161

Property Owner: MERCED JTR MANAGEMENT SERVICES, INC.

Applicant(s) Name: MERCED JTR MANAGEMENT SERVICES, INC.

Project Address/Location: NORTH EXT. OF EDISON ST. / MADDOX CALDWALL C PH. 4

Assessor Parcel Number: PAR. 123-100-004 ; 123-090-014

Parcel Size (Acreage or Square Feet): _____ Building or Suite Square Footage: _____

Are There Any Proposed Building Modifications: Yes No

Estimated Cost of Modifications to Building: \$ N/A

Describe All Proposed Building Modifications: N/A

THIS AREA FOR CITY STAFF USE ONLY
Date Received: 11/17/16
SPR Agenda: 11/23/16 Item No: 5
Zone: X SPR No: 16-161
Historic District: Yes No
Flood Zone: X AE WAE

-- A SEPARATE, DETAILED OPERATIONAL STATEMENT IS HIGHLY RECOMMENDED FOR ALL SUBMITTALS --

OPERATIONS & TRAFFIC INFORMATION

Existing/Prior Building Use: FARM LAND

Proposed Building Use: SINGLE FAMILY HOMES

Proposed Hours of Operation: N/A

Days of Week In Operation (Circle): Su M T W Th F Sa

Number of Employees Per Day: Existing _____ Proposed _____

Number of Customers Per Day (Estimated): Existing _____ Proposed _____

Predicted Peak Operating Hour: N/A

Describe Any Truck Delivery Schedule & Operations: N/A

Please Identify Any Unique or Specific Traffic Patterns That Will Require Accommodations For Operations, Customers, or Employees (Provide Separate Attachment if Necessary): N/A

Describe Any Special Events Planned for the Facility: N/A

Susan Currier

From: Deel, David@DOT <david.deel@dot.ca.gov>
Sent: Friday, December 02, 2016 4:27 PM
To: Susan Currier
Cc: Jason Huckleberry; Navarro, Michael@DOT; Paul Bernal
Subject: Site Plan Review Agenda for November 23

Susan -

Caltrans has a "NO COMMENT" on
SPR 16173 – parcel split
SPR 16174 – 7 lot parcel map
SPR 16169 – resub propane tank
SPR 16175 – temp tent for storage
SPR 16161 – resub 63 lot subd
SPR 16176 – interior T.I.

Thanks,

DAVID DEEL | 559.488.7396 | CALTRANS D6

From: Susan Currier [mailto:Susan.Currier@visalia.city]
Sent: Friday, November 18, 2016 11:44 AM
To: Deel, David@DOT <david.deel@dot.ca.gov>
Subject: Site Plan Review Agenda for November 23

*Please find the attached Site Plan Review Agenda for November 23, 2016.
Please be advised there will be no SPR on November 30, 2016*

*Susan Currier
Planning Assistant
City of Visalia
315 E. Acequia Ave.
Visalia, CA 93291
(559) 713-4436
Fax (559) 713-4813
Email susan.currier@visalia.city
Website www.visalia.city*

The Site Plan Review Agenda is sent out weekly.

If you no longer wish to receive this agenda,
please send a blank email to the following address to unsubscribe:

siteplan-unsubscribe@lists.ci.visalia.ca.us

CITY OF VISALIA
SOLID WASTE DIVISION
336 N. BEN MADDOX
VISALIA CA. 93291
713 - 4500

16-161

Burke & K Rd

COMMERCIAL BIN SERVICE

- No comments.
- Same comments as
- Revisions required prior to submitting final plans. See comments below.
- Resubmittal required. See comments below.
- Customer responsible for all cardboard and other bulky recyclables to be broken down before disposing of in recycle containers.
ALL refuse enclosures must be R-3 OR R-4
- Customer must provide combination or keys for access to locked gates/bins
- Type of refuse service not indicated.
- Location of bin enclosure not acceptable. See comments below.
- Bin enclosure not to city standards double.
- Inadequate number of bins to provide sufficient service. See comments below.
- Drive approach too narrow for refuse trucks access. See comments below.
- Area not adequate for allowing refuse truck turning radius of :
Commercial (X) 50 ft. outside 36 ft. inside; Residential () 35 ft. outside, 20 ft. inside.
- Paved areas should be engineered to withstand a 55,000 lb. refuse truck.
- Bin enclosure gates are required
- Hammerhead turnaround must be built per city standards.
- Cul - de - sac must be built per city standards.
- Bin enclosures are for city refuse containers only. Grease drums or any other items are not allowed to be stored inside bin enclosures.
- Area in front of refuse enclosure must be marked off indicating no parking
- Enclosure will have to be designed and located for a STAB service (DIRECT ACCESS) with no less than 38' clear space in front of the bin, included the front concrete pad.
Customer will be required to roll container out to curb for service.
- Must be a concrete slab in front of enclosure as per city standards
The width of the enclosure by ten(10) feet, minimum of six(6) inches in depth.

Roll off compactor's must have a clearance of 3 feet from any wall on both sides and there must be a minimum of 53 feet clearance in front of the compactor to allow the truck enough room to provide service.

Bin enclosure gates must open 180 degrees and also hinges must be mounted in front of post see page 2 for instructions

COMMENTS

Residential can service ok.

Javier Hernandez, Solid Waste Front Load Supervisor 713-4338
Earl Nielsen, Solid Waste Manager

Date: 10-25-16 / 11-21-16

Site Plan Review # 16161

SITE PLAN REVIEW COMMENTS

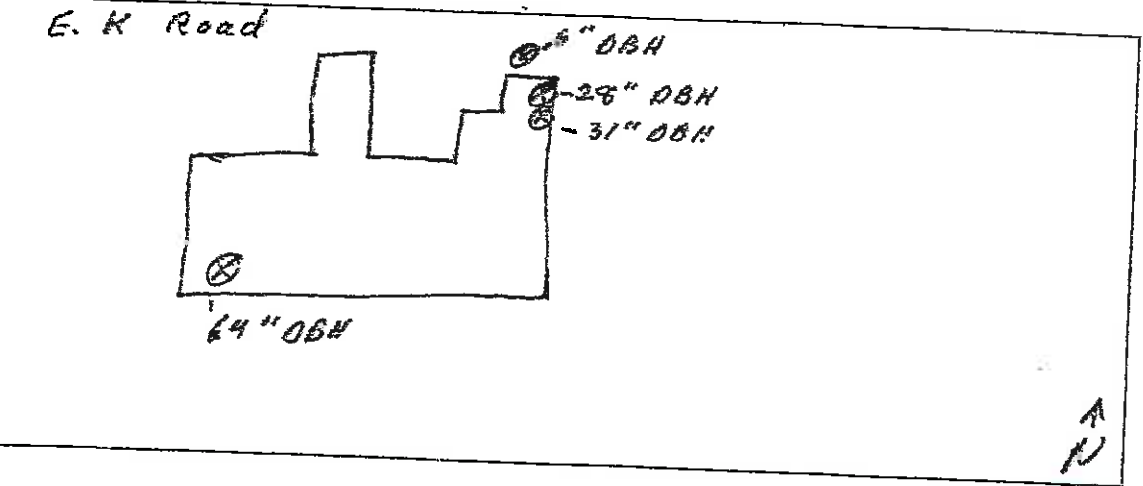

COMMENTS: See Below None

- Please plot and protect all Valley Oak Trees.
- Landscape along parkway to be planted by developer and maintained by a maintenance district.
- All drainage from curb and gutter along streets to be connected to storm drain system.
- All trees planted in street right-of-way to be approved by the Public Works Superintendent of Parks.
- Tie-ins to existing infrastructure may require a bore. Check with the Public Works Department prior to any street cut.

Other Comments: 3 Valley Oaks on Property
1 - 28" DBH Valley Oak
1 - 31" DBH Valley Oak
1 - 64" DBH Valley Oak
1 DBH Valley Oak on Neighbor's property to the North

J. Hooyer
Hooyer
Parks and Urban Forestry Supervisor
713-4295 Fax 559 713-4818

Email: jhooyer@ci.visalia.ca.us

SITE PLAN REVIEW COMMENTS

CITY OF VISALIA TRAFFIC SAFETY DIVISION

November 23, 2016

ITEM NO: <u>5</u>	RESUBMTL
SITE PLAN NO:	SPR16161
PROJECT TITLE:	REIMER PROPERTY TENTATIVE SUBDIVISION MAP
DESCRIPTION:	63 LOT RESIDENTIAL SUBDIVISION (X) (X)
APPLICANT:	FREEMAN RICH
PROP. OWNER:	BIEHLE DIANE R(TR)(DR SURV TR)
LOCATION:	BURKE & K ROAD, APNS:123-100-004, 123-090-008, 123-090-014
APN(S):	123-090-008

THE TRAFFIC DIVISION WILL PROHIBIT ON-STREET PARKING AS DEEMED NECESSARY

- No Comments
- See Previous Site Plan Comments
- Install Street Light(s) per City Standards.
- Install Street Name Blades at *intersections*.
- Install Stop Signs at *intersections of local roads with arterial/collector roadways*.
- Construct parking per City Standards PK-1 through PK-4.
- Construct drive approach per City Standards.
- Traffic Impact Analysis required.
 - Provide more traffic information such as a TIA may be required.
 - Depending on development size, characteristics, etc.,

Additional Comments:



Leslie Blair

**SUBDIVISION & PARCEL MAP
REQUIREMENTS
ENGINEERING DIVISION**

Jason Huckleberry 713-4259
 Adrian Rubalcaba 713-4271

ITEM NO: 5 DATE: NOVEMBER 23, 2016

SITE PLAN NO.: 16-161 RESUBMITTAL
PROJECT TITLE: REIMER PROPERTY TENTATIVE SUBDIVISION MAP
DESCRIPTION: 63 LOT RESIDENTIAL SUBDIVISION (X)
APPLICANT: FREEMAN RICH
PROP. OWNER: BIEHLE DIANE R (TR) (DR SURV TR)
LOCATION: BURKE & K ROAD
APN: 123-090-008, 123-100-004, 123-090-014

SITE PLAN REVIEW COMMENTS

REQUIREMENTS (Indicated by checked boxes)

Submit improvements plans detailing all proposed work; Subdivision Agreement will detail fees & bonding requirements

Bonds, certificate of insurance, cash payment of fees/inspection, and approved map & plan required prior to approval of Final Map.

The Final Map & Improvements shall conform to the Subdivision Map Act, the City's Subdivision Ordinance and Standard Improvements.

A preconstruction conference is required prior to the start of any construction.

Right-of-way dedication required. A title report is required for verification of ownership. by map by deed

City Encroachment Permit Required which shall include an approved traffic control plan.

CalTrans Encroachment Permit Required. CalTrans comments required prior to tentative parcel map approval. CalTrans contacts: David Deel (Planning) 488-4088

Landscape & Lighting District/Home Owners Association required prior to approval of Final Map. Landscape & Lighting District will maintain common area landscaping, street lights, street trees and local streets as applicable. Submit completed Landscape and Lighting District application and filing fee a min. of 75 days before approval of Final Map.

Landscape & irrigation improvement plans to be submitted for each phase. Landscape plans will need to comply with the City's street tree ordinance. The locations of street trees near intersections will need to comply with Plate SD-1 of the City improvement standards. A street tree and landscape master plan for all phases of the subdivision will need to be submitted with the initial phase to assist City staff in the formation of the landscape and lighting assessment district.

Dedicate landscape lots to the City that are to be maintained by the Landscape & Lighting District.

Northeast Specific Plan Area: Application for annexation into Northeast District required 75 days prior to Final Map approval.

Written comments required from ditch company. Contacts: James Silva 747-1177 for Modoc, Persian, Watson, Oakes, Flemming, Evans Ditch and Peoples Ditches; Paul Hendrix 686-3425 for Tulare Irrigation Canal, Packwood and Cameron Creeks; Bruce George 747-5601 for Mill Creek and St. John's River.

Final Map & Improvements shall conform to the City's Waterways Policy. Access required on ditch bank, 12' minimum. Provide wide riparian dedication from top of bank.

Sanitary Sewer master plan for the entire development shall be submitted for approval prior to approval of any portion of the system. The sewer system will need to be extended to the boundaries of the development where future connection and extension is anticipated. The sewer system will need to be sized to serve any future developments that are anticipated to connect to the system.

Grading & Drainage plan required. If the project is phased, then a master plan is required for the entire project area that shall include pipe network sizing and grades and street grades. Prepared by registered civil engineer or project architect. All elevations shall be based on the City's benchmark network. Storm run-off from the project shall be handled as follows: a) directed to the City's existing storm drainage system; b) directed to a permanent on-site basin; or c) directed to a temporary on-site basin is required until a connection with adequate capacity is available to the City's storm drainage system. On-site

- basin: maximum side slopes, perimeter fencing required, provide access ramp to bottom for maintenance. **REFER TO CITY BASIN STDS. SEE ADDL COMMENTS**
- ~~Show Oak trees with drip lines and adjacent grade elevations.~~ Protect Oak trees during construction in accordance with City requirements. A permit is required to remove oak trees. The City will evaluate Oak trees with removal permit applications. Oak tree evaluations by a certified arborist are required to be submitted to the City in conjunction with the tentative map application. A pre-construction conference is required. Contact: Joel Hooyer, City Arborist, 713-4295
 - Show adjacent property grade elevations on improvement plans. A retaining wall will be required for grade differences greater than 0.5 feet at the property line.
 - Relocate existing utility poles and/or facilities. **ONSITE & K ROAD**
 - Underground all existing overhead utilities within the project limits. Existing overhead electrical lines over 50kV shall be exempt from undergrounding.
 - Provide "R" value tests: 1 each at **300' INTERVALS**
 - Traffic indexes per city standards: **REFER TO CITY STREET PAVEMENT STANDARDS**
 - All public streets within the project limits and across the project frontage shall be improved to their full width, subject to available right of way, in accordance with City policies, standards and specifications. **K RD**
 - All lots shall have separate drive approaches constructed to City Standards.
 - Install street striping as required by the City Engineer. **AT DISCRETION OF TRAFFIC ENGINEER**
 - ~~Install sidewalk: 6' ft. wide, with 5' ft. wide parkway on K RD~~
 - Cluster mailbox supports required at 1 per 2 lots, or use postal unit (contact the Postmaster at 732-8073).
 - Subject to existing Reimbursement Agreement to reimburse prior developer:
 - Abandon existing wells per City of Visalia Code. A building permit is required.
 - Remove existing irrigation lines & dispose off-site. Remove existing leach fields and septic tanks.
 - Fugitive dust will be controlled in accordance with the applicable rules of San Joaquin Valley Air District's Regulation VIII. Copies of any required permits will be provided to the City.
 - If the project requires discretionary approval from the City, it may be subject to the San Joaquin Valley Air District's Rule 9510 Indirect Source Review per the rule's applicability criteria. A copy of the approved AIA application will be provided to the City.
 - If the project meets the one acre of disturbance criteria of the State's Storm Water Program, then coverage under General Permit Order 2009-0009-DWQ is required and a Storm Water Pollution Prevention Plan (SWPPP) is needed. A copy of the approved permit and the SWPPP will be provided to the City.

- Comply with prior comments Resubmit with additional information Redesign required

Additional Comments:

- 1. Proposed subdivision shall meet annexation requirements per Planning Dept. conditions.**
- 2. A storm drainage master plan is required for the development as there are no existing storm drain mains serving the county island. The proposed ponding basin shall be properly sized and located to allow for future connection to storm drain trunk line.**
- 3. The City's ultimate storm design for the area is through the extension of a trunk line in Burke St., north to K Rd. Phase 1 of the subdivision will be required to install a service lateral to west terminus of property boundary for future connection when the trunk line is installed. Developer will be responsible for temp basin backfill and any additional SD work onsite.**
- 4. A sanitary sewer master plan is required. City sewer is required to be extended to serve the subdivision. City records indicate a 10" sewer main stub is located in K Rd, east of Santa Fe, and just outside the county boundary; project is required to investigate and confirm proper depth and capacity to tie to existing main. Sewer service main is not a City reimbursable item.**
- 5. Phase 1 of the subdivision will be required to install the local street connection to K Rd., full curb-to-curb and right-of-way improvements.**
- 6. Phase 1 of the subdivision will be required to install frontage improvements on K Rd. along the associated parcel (APN 123-100-004). Additional right-of-way and power pole relocations are required.**

7. K Rd. is a funded 60' collector status roadway in the City's Circulation Element. Any required improvements beyond six-foot pavement, at the discretion of the City Engineer, will be reimbursable per the provisions set forth in Transportation Impact Fee program. The street cross section is 40' curb-to-curb, with 5' parkway & 5' sidewalk. The Site Plan cross section shown is incorrect, revise accordingly at time of Tentative Map submittal.
8. The corner lots do not depict accurate right-of-way for City standard curb ramp returns. The return radius at local street connection to K Rd. shall comply with 30' standard.
9. Street light installation within subdivision and along K Rd. is required. Refer to City standards, electrical plan to accompany civil improvements.
10. Additional public improvements may be required as part of annexation.
11. Development impact fees will apply to each phase. Refer to page 4 for applicable fees.
12. City staff research regarding the possibility of purchasing the temporary basin area to utilize as a new City regional basin has concluded that City will not need an additional basin for the area.

SUMMARY OF APPLICABLE DEVELOPMENT IMPACT FEES

Site Plan No: **16-161 RESUBMITTAL**

Date: **11/23/2016**

Summary of applicable Development Impact Fees to be collected at the time of final/parcel map recordation:

(Preliminary estimate only! Final fees will be based on approved subdivision map & improvements plans and the fee schedule in effect at the time of recordation.)

(Fee Schedule Date: **10/1/2016**)

(Project type for fee rates: **SFD SUBDIVISION**)

Existing uses may qualify for credits on Development Impact Fees.

FEE ITEM	FEE RATE
<input checked="" type="checkbox"/> Trunk Line Capacity Fee	\$751/UNIT
<input type="checkbox"/> Sewer Front Foot Fee	
<input checked="" type="checkbox"/> Storm Drainage Acquisition Fee	\$2,984/AC
<input checked="" type="checkbox"/> Park Acquisition Fee	\$1,477/AC
<input type="checkbox"/> Northeast Acquisition Fee Total	
Storm Drainage	
Block Walls	
Parkway Landscaping	
Bike Paths	
<input checked="" type="checkbox"/> Waterways Acquisition Fee	\$2,435/AC

Additional Development Impact Fees will be collected at the time of issuance of building permits.

City Reimbursement:

- 1.) No reimbursement shall be made except as provided in a written reimbursement agreement between the City and the developer entered into prior to commencement of construction of the subject planned facilities.
- 2.) Reimbursement is available for the development of arterial/collector streets as shown in the City's Circulation Element and funded in the City's transportation impact fee program. The developer will be reimbursed for construction costs and right of way dedications as outlined in Municipal Code Section 16.44. Reimbursement unit costs will be subject to those unit costs utilized as the basis for the transportation impact fee.
- 3.) Reimbursement is available for the construction of storm drain trunk lines and sanitary sewer trunk lines shown in the City's Storm Water Master Plan and Sanitary Sewer System Master Plan. The developer will be reimbursed for construction costs associated with the installation of these trunk lines.



Adrian Rubalcaba

City of Visalia
Building: Site Plan
Review Comments

ITEM NO: 5 DATE: November 23, 2016
SITE PLAN NO: SPR16161 **RESUBMIT**
PROJECT TITLE: REIMER PROPERTY TENTATIVE SUBDIVISION MAP
DESCRIPTION: 63 LOT RESIDENTIAL SUBDIVISION (X) (X)
APPLICANT: FREEMAN RICH
PROP OWNER: BIEHLE DIANE R(TR)(DR SURV TR)
LOCATION: BURKE & K ROAD, APNS:123-100-004, 123-090-008,
APN(S): 123-090-008

NOTE: These are general comments and DO NOT constitute a complete plan check for your specific project
Please refer to the applicable California Codes & local ordinance for additional requirements.

- Business Tax Certification is required. *For information call (559) 713-4326*
- A building permit will be required. *For information call (559) 713-4444*
- Submit 4 sets of professionally prepared plans and 2 sets of calculations. (Small Tenant Improvements)
- Submit 4 sets of plans prepared by an architect or engineer. Must comply with 2013 California Building Cod Sec. 2308 for conventional light-frame construction or submit 2 sets of engineered calculations.
- Indicate abandoned wells, septic systems and excavations on construction plans.
- You are responsible to ensure compliance with the following checked items:

 Meet State and Federal requirements for accessibility for persons with disabilities.
- A path of travel, parking, common area and public right of way must comply with requirements for access for persons with disabilities.
- Multi family units shall be accessible or adaptable for persons with disabilities.
- Maintain sound transmission control between units minimum of 50 STC.
- Maintain fire-resistive requirements at property lines.
- A demolition permit & deposit is required. *For information call (559) 713-4444*
- Obtain required clearance from San Joaquin Valley Air Pollution Board. Prior to any demolition work
For information call (661) 392-5500
- Location of cashier must provide clear view of gas pump island
- Plans must be approved by the Tulare County Health Department. *For information call (559) 624-7400*
- Project is located in flood zone _____ * Hazardous materials report.
- Arrange for an on-site inspection. (Fee for inspection \$157.00) *For information call (559) 713-4444*
- School Development fees. Commercial \$0.56 per square foot. Residential \$3.75 per square foot.
- Existing address must be changed to be consistent with city address. *For information call (559) 713-4320*
- Acceptable as submitted
- No comments
- See previous comments dated: _____

Special comments: _____

Signature _____ Date: 11/23/16

QUALITY ASSURANCE DIVISION
SITE PLAN REVIEW COMMENTS

ITEM NO: 5 DATE: November 23, 2016
SITE PLAN NO: SPR16161 *RESUBMIT*
PROJECT TITLE: REIMER PROPERTY TENTATIVE SUBDIVISION MAP
DESCRIPTION: 63 LOT RESIDENTIAL SUBDIVISION (X) (X)
APPLICANT: FREEMAN RICH
PROP OWNER: BIEHLE DIANE R(TR)(DR SURV TR)
LOCATION: BURKE & K ROAD, APNS:123-100-004, 123-090-008,
APN(S): 123-090-008

YOU ARE REQUIRED TO COMPLY WITH THE CITY OF VISALIA WASTEWATER ORDINANCE 13.08 RELATIVE TO CONNECTION TO THE SEWER, PAYMENT OF CONNECTION FEES AND MONTHLY SEWER USER CHARGES. THE ORDINANCE ALSO RESTRICTS THE DISCHARGE OF CERTAIN NON-DOMESTIC WASTES INTO THE SANITARY SEWER SYSTEM.

YOUR PROJECT IS ALSO SUBJECT TO THE FOLLOWING REQUIREMENTS:

- WASTEWATER DISCHARGE PERMIT APPLICATION
- SAND AND GREASE INTERCEPTOR – 3 COMPARTMENT _____
- GREASE INTERCEPTOR min. 1000 GAL
- GARBAGE GRINDER – ¾ HP. MAXIMUM _____
- SUBMISSION OF A DRY PROCESS DECLARATION _____
- NO SINGLE PASS COOLING WATER IS PERMITTED _____
- OTHER _____
- SITE PLAN REVIEWED – NO COMMENTS

CALL THE QUALITY ASSURANCE DIVISION AT (559) 713-4529 IF YOU HAVE ANY QUESTIONS.

CITY OF VISALIA
PUBLIC WORKS DEPARTMENT
QUALITY ASSURANCE DIVISION
7579 AVENUE 288
VISALIA, CA 93277



AUTHORIZED SIGNATURE

11-19-16

DATE

CITY OF VISALIA
315 E. ACEQUIA STREET
VISALIA, CA 93291

**NOTICE OF A PROPOSED
NEGATIVE DECLARATION**

Project Title: Annexation No. 2017-17 and Tentative Subdivision Map No. 5559 (Reimer Subdivision)

Project Description: The project proponents are requesting to annex and subdivide 15.2 acres. The project site is located in the County of Tulare.

Reimer Tentative Subdivision Map No. 5559: A request to subdivide 15.2 acres into 65 lots and a remainder parcel for residential development. The project is zoned R-1-6 (Single-family Residential, 6,000 sq.ft. minimum lot size), and is located on the south side of K Road Ferguson Ave., approximately 230 feet east of Burke Road. (APNs 123-090-008, -014, and 123-100-004)

Annexation No. 2017-01: A request to annex three parcels totaling 15.2 acres into the City limits of Visalia, and to detach from Tulare County Service Area No.1. Upon annexation, the site would be zoned R-1-6 (Single-Family Residential 6,000 square foot minimum site area), which is consistent with the General Plan Land Use Designation of Low Density Residential. The site is located on the south side of K Road Ferguson Ave., approximately 230 feet east of Burke Road. (APNs 123-090-008, -014, and 123-100-004)

Project Location: The site is located on the south side of K Road Ferguson Ave., approximately 230 feet east of Burke Road. (APNs 123-090-008, -014, and 123-100-004)

Contact Person: Paul Scheibel, AICP, Principal Planner

Phone: (559) 713-4369

Pursuant to City Ordinance No. 2388, the Environmental Coordinator of the City of Visalia has reviewed the proposed project described herein and has found that the project will not result in any significant effect upon the environment because of the reasons listed below:

Copies of the initial study and other documents relating to the subject project may be examined by interested parties at the Planning Division in City Hall East, at 315 East Acequia Avenue, Visalia, CA.

Comments on this proposed Mitigated Negative Declaration will be accepted from April 3, 2017 to April 24, 2017.

Date: 4-3-17

Signed: _____

Paul Scheibel, AICP
Environmental Coordinator
City of Visalia

ATTACHMENT 4

NEGATIVE DECLARATION

Project Title: Annexation No. 2017-01 and Tentative Subdivision Map No. 5559

Project Description: The project proponents are requesting to annex and subdivide 15.2 acres. The project site is located in the County of Tulare:

Reimer Tentative Subdivision Map No. 5559: A request to subdivide 15.2 acres into 65 lots and a remainder parcel for residential development. The project is zoned R-1-6 (Single-family Residential, 6,000 sq.ft. minimum lot size), and is located on the south side of K Road Ferguson Ave., approximately 230 feet east of Burke Road. (APNs 123-090-008, -014, and 123-100-004)

Annexation No. 2017-01: A request to annex three parcels totaling 15.2 acres into the City limits of Visalia, and to detach from Tulare County Service Area No.1. Upon annexation, the site would be zoned R-1-6 (Single-Family Residential 6,000 square foot minimum site area), which is consistent with the General Plan Land Use Designation of Low Density Residential. The site is located on the south side of K Road Ferguson Ave., approximately 230 feet east of Burke Road. (APNs 123-090-008, -014, and 123-100-004)

Project Location: The site is located on the south side of K Road Ferguson Ave., approximately 230 feet east of Burke Road. (APNs 123-090-008, -014, and 123-100-004)

Project Facts: Refer to Initial Study for project facts, plans and policies, and discussion of environmental effects.

Attachments:

Initial Study	(X)
Environmental Checklist	(X)
Maps	(X)

DECLARATION OF NO SIGNIFICANT EFFECT:

This project will not have a significant effect on the environment for the following reasons:

- (a) The project does not have the potential to degrade the quality of the environment, substantially reduce the habitat of a fish or wildlife species, cause a fish or wildlife population to drop below self-sustaining levels, threaten to eliminate a plant or animal community, reduce the number or restrict the range of a rare or endangered plant or animal, or eliminate important examples of the major periods of California history or prehistory.
- (b) The project does not have the potential to achieve short-term environmental goals to the disadvantage of long-term environmental goals.
- (c) The project does not have environmental effects which are individually limited but cumulatively considerable. Cumulatively considerable means that the incremental effects of an individual project are considerable when viewed in connection with the effects of past projects, the effects of other current projects, and the effects of probable future projects.
- (d) The environmental effects of the project will not cause substantial adverse effects on human beings, either directly or indirectly.

This Mitigated Negative Declaration has been prepared by the City of Visalia Planning Division in accordance with the California Environmental Quality Act of 1970, as amended. A copy may be obtained from the City of Visalia Planning Division Staff during normal business hours.

APPROVED
Paul Scheibel, AICP
Environmental Coordinator

By: 

Date Approved: 4-3-17
Review Period: 20 days

INITIAL STUDY

I. GENERAL

Reimer Tentative Subdivision Map No. 5559: A request to subdivide 15.2 acres into 65 lots and a remainder parcel for residential development. The project is zoned R-1-6 (Single-family Residential, 6,000 sq.ft. minimum lot size), and is located on the south side of K Road Ferguson Ave., approximately 230 feet east of Burke Road. (APNs 123-090-008, -014, and 123-100-004)

Annexation No. 2017-01: A request to annex three parcels totaling 15.2 acres into the City limits of Visalia, and to detach from Tulare County Service Area No.1. Upon annexation, the site would be zoned R-1-6 (Single-Family Residential 6,000 square foot minimum site area), which is consistent with the General Plan Land Use Designation of Low Density Residential. The site is located on the south side of K Road Ferguson Ave., approximately 230 feet east of Burke Road. (APNs 123-090-008, -014, and 123-100-004)

B. Identification of the Environmental Setting:

The 15.2-acre project is located on the south side of K Road, approximately 230 feet east of Burke Road, in unincorporated Tulare County. (APNs 123-090-008, -014, and 123-100-004)

The surrounding uses are as follows:

	General Plan (2014 Land Use)	Zoning	Existing uses
North:	RMD	County A-20	Single-family residences
South:	RLD	R-1-6	Developed subdivision
East:	RLD	R-1-6	Feral crop land
West:	RLD	County A-20	Single-family residences

Fire and police protection services, street maintenance of public streets, refuse collection, and wastewater treatment will be provided by the City of Visalia upon annexation and the development of the project area.

C. Plans and Policies: The General Plan Land Use Diagram, adopted October 14, 2014, generally designates the project area as Residential. The Zoning Map, adopted in 1993, designates the proposed Annexation site as County zoning. If successfully annexed, the entire 15.2-acre parcel would be zoned R-1-6, which is consistent with the General Plan Land Use Designation of Low Density Residential, as noted in Table 9-1 Consistency Between the Plan and Zoning of the General Plan.

The proposed project is consistent with Land Use Policies LU-P-19 and LU-P-20 of the General Plan. Policy LU-P-19 states; "Ensure that growth occurs in a compact and concentric fashion by implementing the General Plan's phased growth strategy," while LU-P-20 states, "allow annexation and development of residential, commercial, and industrial land to occur within the "Tier I" Urban Development Boundary (UDB) at any time, consistent with the City's Land Use Diagram." The project is located in the Tier 1 UDB.

Furthermore, the project is consistent with Policy LU-P-34. The conversion of the site from an agricultural use does not require mitigation to offset the loss of prime farmland as stated in Policy LU-P-34. The policy states; "the mitigation program shall specifically allow exemptions for conversion of agricultural lands in Tier I."

II. ENVIRONMENTAL IMPACTS

No significant adverse environmental impacts have been identified for this project that cannot be mitigated to a non-significant level. The City of Visalia Land Use Element, Circulation Element, Zoning and Subdivision Ordinances contain policies and regulations that are designed to mitigate impacts to a level of non-significance.

To ensure that these requirements are met for the proposed project, the project shall be developed and shall operate in

substantial compliance with the standard zoning and subdivision standards of the Visalia Municipal Code, and by the special conditions placed on the project through the City's discretionary authority.

The City of Visalia Zoning Ordinance contains guidelines, criteria, and requirements for the mitigation of potential impacts including, but not limited to light/glare, visibility screening, noise, biological, cultural, safety, and transportation mobility to eliminate and/or reduce potential impacts to a level of non-significance.

In addition to the codes and standards noted above, mitigation measures have been applied to the project as follows:

IV. PROJECT COMPATIBILITY WITH EXISTING ZONES AND PLANS

The proposed project would be compatible with the General Plan, Zoning and Subdivision Ordinances as it relates to surrounding properties.

V. SUPPORTING DOCUMENTATION

The following documents are hereby incorporated into this Negative Declaration and Initial Study by reference:

- Visalia General Plan Update. Dyett & Bhatia, October 2014.
- Visalia City Council Resolution No. 2014-38 (Certifying the Visalia General Plan Update), passed and adopted October 14, 2014.
- Visalia General Plan Update Final Environmental impact Report (SCH No. 2010041078). Dyett & Bhatia, June 2014.
- Visalia General Plan Update Draft Environmental Impact Report (SCH No. 2010041078). Dyett & Bhatia, March 2014.
- Visalia City Council Resolution No. 2014-37 (Certifying the EIR for the Visalia General Plan Update), passed and adopted October 14, 2014.
- Visalia Municipal Code, including Title 17 (Zoning Ordinance).
- California Environmental Quality Act Guidelines.
- City of Visalia, California, Climate Action Plan, Draft Final. Strategic Energy Innovations, December 2013.
- Visalia City Council Resolution No. 2014-36 (Certifying the Visalia Climate Action Plan), passed and adopted October 14, 2014.
- City of Visalia Storm Water Master Plan. Boyle Engineering Corporation, September 1994.
- City of Visalia Sanitary Sewer Master Plan. City of Visalia, 1994.
- TSM 5559 Map Exhibit

VII. NAME OF PERSON WHO PREPARED INITIAL STUDY

Paul Scheibel, AICP
Principal Planner

Josh McDonnell, AICP
City Planner

**INITIAL STUDY
ENVIRONMENTAL CHECKLIST**

Name of Proposal	Annexation No. 2017-01 & Tentative Subdivision Map No. 5559		
NAME OF PROPONENT:	San Joaquin Valley Homes	NAME OF AGENT:	Jim Robinson
Address of Proponent:	222 N. Garden St., Visalia CA 93291	Address of Agent:	222 N. Garden St., Visalia CA 93291
Telephone Number:	(559) 732-2600	Telephone Number:	(559) 732-2600
Date of Review	February 10, 2017	Lead Agency:	City of Visalia

The following checklist is used to determine if the proposed project could potentially have a significant effect on the environment. Explanations and information regarding each question follow the checklist.

- 1 = No Impact 2 = Less Than Significant Impact
3 = Less Than Significant Impact with Mitigation Incorporated 4 = Potentially Significant Impact

I. AESTHETICS

Would the project:

- 2 a) Have a substantial adverse effect on a scenic vista?
- 1 b) Substantially damage scenic resources, including, but not limited to, trees, rock outcroppings, and historic buildings within a state scenic highway?
- 2 c) Substantially degrade the existing visual character or quality of the site and its surroundings?
- 2 d) Create a new source of substantial light or glare that would adversely affect day or nighttime views in the area?

II. AGRICULTURAL RESOURCES

In determining whether impacts to agricultural resources are significant environmental effects, lead agencies may refer to the California Agricultural Land Evaluation and Site Assessment Model (1997) prepared by the California Dept. of Conservation as an optional model to use in assessing impacts on agriculture and farmland. In determining whether impacts to forest resources, including timberland, are significant environmental effects, lead agencies may refer to information compiled by the California Department of Forestry and Fire Protection regarding the state's inventory of forest land, including the Forest and Range Assessment Project and the Forest Legacy Assessment project; and forest carbon measurement methodology provided in Forest Protocols adopted by the California Air Resources Board. Would the project:

- 2 a) Convert Prime Farmland, Unique Farmland, or Farmland of Statewide Importance, as shown on the maps prepared pursuant to the Farmland Mapping and Monitoring Program of the California Resources Agency to non-agricultural use?
- 2 b) Conflict with existing zoning for agricultural use, or a Williamson Act contract?
- 1 c) Conflict with existing zoning for, or cause rezoning of, forest land (as defined in Public Resources Code section 12220(g)), timberland (as defined by Public Resources Code section 4526), or timberland zoned Timberland Production (as defined by Government Code section 51104(g))?
- 1 d) Result in the loss of forest land or conversion of forest land to non-forest use?
- 2 e) Involve other changes in the existing environment which, due to their location or nature, could result in conversion of Farmland to nonagricultural use?

III. AIR QUALITY

Where available, the significance criteria established by the applicable air quality management or air pollution control district may be relied upon to make the following determinations. Would the project:

- 2 a) Conflict with or obstruct implementation of the applicable air quality plan?

- 2 b) Violate any air quality standard or contribute substantially to an existing or projected air quality violation?
- 2 c) Result in a cumulatively considerable net increase of any criteria pollutant for which the project region is non-attainment under applicable federal or state ambient air quality standard (including releasing emissions which exceed quantitative thresholds for ozone precursors)?
- 1 d) Expose sensitive receptors to substantial pollutant concentrations?
- 1 e) Create objectionable odors affecting a substantial number of people?

IV. BIOLOGICAL RESOURCES

Would the project:

- 2 a) Have a substantial adverse effect, either directly or through habitat modifications, on any species identified as a candidate, sensitive, or special status species in local or regional plans, policies, or regulations, or by the California Department of Fish and Game or U.S. Fish and Wildlife Service?
- 2 b) Have a substantial adverse effect on any riparian habitat or other sensitive natural community identified in local or regional plans, policies, regulations, or by the California Department of Fish and Game or U.S. Fish and Wildlife Service?
- 2 c) Have a substantial adverse effect on federally protected wetlands as defined by Section 404 of the Clean Water Act (including but not limited to, marsh, vernal pool, coastal, etc.) through direct removal, filling, hydrological interruption, or other means?
- 2 d) Interfere substantially with the movement of any native resident or migratory fish or wildlife species or with established native resident or migratory wildlife corridors, or impede the use of native wildlife nursery sites?
- 2 e) Conflict with any local policies or ordinances protecting biological resources, such as a tree preservation policy or ordinance?
- 1 f) Conflict with the provisions of an adopted Habitat Conservation Plan, Natural Community Conservation Plan, or other approved local, regional, or state habitat conservation plan?

V. CULTURAL RESOURCES

Would the project:

- 2 a) Cause a substantial adverse change in the significance of a historical resource as defined in Public Resources Code Section 15064.5?
- 2 b) Cause a substantial adverse change in the significance of an archaeological resource pursuant to Public Resources Code Section 15064.5?
- 2 c) Directly or indirectly destroy a unique paleontological resource or site, or unique geologic feature?
- 2 d) Disturb any human remains, including those interred outside of formal cemeteries?

VI. GEOLOGY AND SOILS

Would the project:

- a) Expose people or structures to potential substantial adverse effects, including the risk of loss, injury, or death involving:
 - 1 i) Rupture of a known earthquake fault, as delineated on the most recent Alquist-Priolo Earthquake Fault Zoning Map issued by the State Geologist for the area or based on other substantial evidence of a known fault?
 - 1 ii) Strong seismic ground shaking?
 - 1 iii) Seismic-related ground failure, including liquefaction?
 - 1 iv) Landslides?
- 1 b) Result in substantial soil erosion or loss of topsoil?
- 1 c) Be located on a geologic unit or soil that is unstable, or that would become unstable as a result of the project, and potentially result in on- or off-site landslide, lateral spreading, subsidence, liquefaction, or collapse?
- 1 d) Be located on expansive soil, as defined in Table 18-1-B of the Uniform Building Code (1994), creating substantial risks to life or property?
- 1 e) Have soils incapable of adequately supporting the use of septic tanks or alternative waste water disposal systems where sewers are not available for the disposal of waste water?

VII. GREENHOUSE GAS EMISSIONS

Would the project:

- 2 a) Generate greenhouse gas emissions, either directly or indirectly, that may have a significant impact on the environment?
- 2 b) Conflict with an applicable plan, policy, or regulation adopted for the purpose of reducing the emissions of greenhouse gases?

VIII. HAZARDS AND HAZARDOUS MATERIALS

Would the project:

- 1 a) Create a significant hazard to the public or the environment through the routine transport, use, or disposal of hazardous materials?
- 1 b) Create a significant hazard to the public or the environment through reasonably foreseeable upset and accident conditions involving the release of hazardous materials into the environment?
- 1 c) Emit hazardous emissions or handle hazardous or acutely hazardous materials, substances, or waste within one-quarter mile of an existing or proposed school?
- 1 d) Be located on a site which is included on a list of hazardous materials sites compiled pursuant to Government Code section 65962.5 and, as a result, would it create a significant hazard to the public or the environment?
- 2 e) For a project located within an airport land use plan or, where such a plan has not been adopted, within two miles of a public airport or public use airport, would the project result in a safety hazard for people residing or working in the project area?
- 1 f) For a project within the vicinity of a private airstrip, would the project result in a safety hazard for people residing or working in the project area?
- 1 g) Impair implementation of or physically interfere with an adopted emergency response plan or emergency evacuation plan?
- 1 h) Expose people or structures to a significant risk of loss, injury or death involving wildland fires, including where wildlands are adjacent to urbanized areas or where residences are intermixed with wildlands?

IX. HYDROLOGY AND WATER QUALITY

Would the project:

- 2 a) Violate any water quality standards of waste discharge requirements?
- 2 b) Substantially deplete groundwater supplies or interfere substantially with groundwater recharge such that there would be a net deficit in aquifer volume or a lowering of the local groundwater table level (e.g., the production rate of pre-existing nearby wells would drop to a level which would not support existing land uses or planned uses for which permits have been granted)?
- 2 c) Substantially alter the existing drainage pattern of the site or area, including through the alteration of the course of a stream or river, in a manner which would result in substantial erosion or siltation on- or off-site?
- 2 d) Substantially alter the existing drainage pattern of the site or area, including through the alteration of the course of a stream or river, or substantially increase the rate or amount of surface runoff in a manner which would result in flooding on- or off-site?
- 2 e) Create or contribute runoff water which would exceed the capacity of existing or planned stormwater drainage systems or provide substantial additional sources of polluted runoff?
- 1 f) Otherwise substantially degrade water quality?
- 1 g) Place housing within a 100-year flood hazard area as mapped on a federal Flood Hazard Boundary or Flood Insurance Rate Map or other flood hazard delineation map?
- 1 h) Place within a 100-year flood hazard area structures which would impede or redirect flood flows?
- 1 i) Expose people or structures to a significant risk of loss, injury or death involving flooding, including flooding as a result of the failure of a levee or dam?
- 1 j) Inundation by seiche, tsunami, or mudflow?

X. LAND USE AND PLANNING

Would the project:

- 1 a) Physically divide an established community?
- 1 b) Conflict with any applicable land use plan, policy, or regulation of an agency with jurisdiction over the project (including, but not limited to the general plan, specific plan, local

coastal program, or zoning ordinance) adopted for the purpose of avoiding or mitigating an environmental effect?

- 1 c) Conflict with any applicable habitat conservation plan or natural community conservation plan?

XI. MINERAL RESOURCES

Would the project:

- 1 a) Result in the loss of availability of a known mineral resource that would be of value to the region and the residents of the state?
- 1 b) Result in the loss of availability of a locally-important mineral resource recovery site delineated on a local general plan, specific plan or other land use plan?

XII. NOISE

Would the project:

- 2 a) Cause exposure of persons to or generation of noise levels in excess of standards established in the local general plan or noise ordinance, or applicable standards of other agencies?
- 1 b) Cause exposure of persons to or generation of excessive groundborne vibration or groundborne noise levels?
- 2 c) Cause a substantial permanent increase in ambient noise levels in the project vicinity above levels existing without the project?
- 1 d) Cause a substantial temporary or periodic increase in ambient noise levels in the project vicinity above levels existing without the project?
- 1 e) For a project located within an airport land use plan or, where such a plan has not been adopted, within two miles of a public airport or public use airport, would the project expose people residing or working in the project area to excessive noise levels?
- 1 f) For a project within the vicinity of a private airstrip, would the project expose people residing or working in the project area to excessive noise levels?

XIII. POPULATION AND HOUSING

Would the project:

- 2 a) Induce substantial population growth in an area, either directly (for example, by proposing new homes and businesses) or indirectly (for example, through extension of roads or other infrastructure)?

- 1 b) Displace substantial numbers of existing housing, necessitating the construction of replacement housing elsewhere?

- 1 c) Displace substantial numbers of people, necessitating the construction of replacement housing elsewhere?

XIV. PUBLIC SERVICES

Would the project:

- 1 a) Would the project result in substantial adverse physical impacts associated with the provision of new or physically altered governmental facilities, need for new or physically altered governmental facilities, the construction of which could cause significant environmental impacts, in order to maintain acceptable service ratios, response times or other performance objectives for any of the public services:

- 1 i) Fire protection?
- 1 ii) Police protection?
- 2 iii) Schools?
- 1 iv) Parks?
- 1 v) Other public facilities?

XV. RECREATION

Would the project:

- 2 a) Would the project increase the use of existing neighborhood and regional parks or other recreational facilities such that substantial physical deterioration of the facility would occur or be accelerated?
- 1 b) Does the project include recreational facilities or require the construction or expansion of recreational facilities which might have an adverse physical effect on the environment?

XVI. TRANSPORTATION / TRAFFIC

Would the project:

- 1 a) Conflict with an applicable plan, ordinance or policy establishing measures of effectiveness for the performance of the circulation system, taking into account all modes of transportation including mass transit and non-motorized travel and relevant components of the circulation system, including but not limited to intersections, streets, highways and freeways, pedestrian and bicycle paths, and mass transit?
- 2 b) Conflict with an applicable congestion management program, including, but not limited to level of service standards and travel demand measures, or other standards established by the

county congestion management agency for designated roads or highways?

- 1 c) Result in a change in air traffic patterns, including either an increase in traffic levels or a change in location that results in substantial safety risks?
- 1 d) Substantially increase hazards due to a design feature (e.g., sharp curves or dangerous intersections) or incompatible uses (e.g., farm equipment)?
- 1 e) Result in inadequate emergency access?
- 1 f) Conflict with adopted policies, plans, or programs regarding public transit, bicycle, or pedestrian facilities, or otherwise decrease the performance or safety of such facilities?

XVII UTILITIES AND SERVICE SYSTEMS

Would the project:

- 1 a) Exceed wastewater treatment requirements of the applicable Regional Water Quality Control Board?
- 2 b) Require or result in the construction of new water or wastewater treatment facilities or expansion of existing facilities, the construction of which could cause significant environmental effects?
- 2 c) Require or result in the construction of new storm water drainage facilities or expansion of existing facilities, the construction of which could cause significant environmental effects?
- 1 d) Have sufficient water supplies available to service the project from existing entitlements and resources, or are new or expanded entitlements needed?
- 1 e) Result in a determination by the wastewater treatment provider which serves or may serve the project that it has adequate capacity to serve the project's projected demand in addition to the provider's existing commitments?
- 1 f) Be served by a landfill with sufficient permitted capacity to accommodate the project's solid waste disposal needs?
- 1 g) Comply with federal, state, and local statutes and regulations related to solid waste?

XVIII TRIBAL CULTURAL RESOURCES

Would the project cause a substantial adverse change in the significance of a tribal cultural resource, defined in Public Resources Code section 21074 as either a site, feature, place, cultural landscape that is geographically defined in terms of the size and scope of the landscape, sacred place, or object with cultural value to a California Native American tribe, and that is:

2 a) Listed or eligible for listing in the California Register of Historical Resources, or in a local register of historical resources as defined in Public Resources Code section 5020.1(k), or

2 b) A resource determined by the lead agency, in its discretion and supported by substantial evidence, to be significant pursuant to criteria set forth in subdivision (c) of Public Resources Code Section 5024.1. In applying the criteria set forth in subdivision (c) of Public Resource Code Section 5024.1, the lead agency shall consider the significance of the resource to a California Native American tribe.

IXX MANDATORY FINDINGS OF SIGNIFICANCE

Would the project:

- 2 a) Does the project have the potential to degrade the quality of the environment, substantially reduce the habitat of a fish or wildlife species, cause a fish or wildlife population to drop below self-sustaining levels, threaten to eliminate a plant or animal community, reduce the number or restrict the range of a rare or endangered plant or animal or eliminate important examples of the major periods of California history or prehistory?
- 2 b) Does the project have impacts that are individually limited, but cumulatively considerable? ("Cumulatively considerable" means that the incremental effects of a project are considerable when viewed in connection with the effects of past projects, the effects of other current projects, and the effects of probable future projects)?
- 2 c) Does the project have environmental effects which will cause substantial adverse effects on human beings, either directly or indirectly?

Note: Authority cited: Sections 21083 and 21083.05, Public Resources Code. Reference: Section 65088.4, Gov. Code; Sections 21080(c), 21080.1, 21080.3, 21083, 21083.05, 21083.3, 21093, 21094, 21095, and 21151, Public Resources Code; *Sundstrom v. County of Mendocino*, (1988) 202 Cal.App.3d 296; *Leonoff v. Monterey Board of Supervisors*, (1990) 222 Cal.App.3d 1337; *Eureka Citizens for Responsible Govt. v. City of Eureka* (2007) 147 Cal.App.4th 357; *Protect the Historic Amador Waterways v. Amador Water Agency* (2004) 116 Cal.App.4th at 1109; *San Franciscans Upholding the Downtown Plan v. City and County of San Francisco* (2002) 102 Cal.App.4th 653. Revised 2009

DISCUSSION OF ENVIRONMENTAL EVALUATION

I. AESTHETICS

- a. This project will not adversely affect the view of any scenic vistas. The Sierra Nevada mountain range may be considered a scenic vista, but views of the range will not be adversely impacted or significantly by the project.
- b. There are no scenic resources on the site.
- c. Development plans are subject to the City's Site Plan Review process and may be subject to further environmental and/or discretionary review. Thus, the project would not substantially degrade the existing visual character of the site and its surroundings.
- d. The project, when developed, will create new sources of light that are typical of urban development.

I. AGRICULTURAL RESOURCES

- a. The 15.2-acre annexation and development portion of the project is on property that is identified as Prime Farmland on maps prepared by the California Resources, and will involve the conversion of the property to non-agricultural use. The site is not under Williamson Act Contract.

The Visalia General Plan Update Environmental Impact Report (EIR) has already considered the environmental impacts of the conversion of properties within the Planning Area, which includes the subject property, into non-agriculture uses. Overall, the General Plan results in the conversion of over 14,000 acres of Important Farmland to urban uses, which is considered significant and unavoidable. Aside from preventing development altogether, the conversion of Important Farmland to urban uses cannot be directly mitigated. However, the General Plan contains multiple policies that together work to limit conversion only to the extent needed to accommodate long-term growth. The General Plan policies identified under Impact 3.5-1 of the EIR serve as the mitigation, which assists in reducing the severity of the impact to the extent possible while still achieving the General Plan's goals of accommodating a certain amount of growth to occur within the Planning Area. These policies include the implementation of a three-tier growth boundary system that assists in protecting open space around the City fringe and maintaining compact development within the City limits.

The 15.2-acre annexation site is within the Urban Development Tier 1 Boundary. Development of residential, commercial, and industrial lands in Tier 1 may occur at any time. The proposed project is

consistent with Land Use Policies LU-P-19 and LU-P-20 of the General Plan. Policy LU-P-19 states; "Ensure that growth occurs in a compact and concentric fashion by implementing the General Plan's phased growth strategy," while LU-P-20 states; allow annexation and development of residential, commercial, and industrial land to occur within the "Tier I" Urban Development Boundary (UDB) at any time, consistent with the City's Land Use Policies. Consequently, the project would not have a significant impact on agricultural resources, although it would benefit the goal of facilitating compact urban development projecting from existing urban development, which was identified as a mitigating factor to preserving the viability of agricultural lands in or near the City of Visalia.

The project will be consistent with Policy LU-P-34. The conversion of the site from an agricultural use to urban development does not require mitigation to offset the loss of prime farmland as stated in Policy LU-P-34. The policy states; "the mitigation program shall specifically allow exemptions for conversion of agricultural lands in Tier I."

- b. The 15.2-acre unincorporated portion of the project area has a County AE-20 zoning designation. The project is bordered by existing urban development to the north, south, and west.
- c. There is no forest or timber land currently located on the site.
- d. There is no forest or timber land currently located on the site.
- e. The proposed annexation and subdivision map will result in the conversion of farmland to a non-agricultural use. The City's General Plan designates this property for urban development by designating the site for Residential. The request to annex the project and subdivide the site is consistent with Land Use Policies LU-P-19 and LU-P-20 of the General Plan. Policy LU-P-19 states; "Ensure that growth occurs in a compact and concentric fashion by implementing the General Plan's phased growth strategy," while LU-P-20 states; allow annexation and development of residential, commercial, and industrial land to occur within the "Tier I" Urban Development Boundary (UDB) at any time.

Furthermore, the project is consistent with Policy LU-P-34. The conversion of the site from an agricultural use to urban development does not require mitigation to offset the loss of prime farmland as stated in Policy LU-P-34. The policy states; "the mitigation program shall specifically allow

exemptions for conversion of agricultural lands in Tier I.”

II. AIR QUALITY

- a. The project is located in an area that is under the jurisdiction of the San Joaquin Valley Air Pollution Control District (SJVAPCD). The project in itself does not disrupt implementation of the San Joaquin Regional Air Quality Management Plan, and will therefore be a less than significant impact.
- b. Development under the Visalia General Plan will result in emissions that will exceed thresholds established by the SJVAPCD for PM10 and PM2.5. The project will contribute to a net increase of criteria pollutants and will therefore contribute to exceeding the thresholds. Also the project could result in short-term air quality impacts related to dust generation and exhaust due to construction and grading activities. This site was evaluated in the Visalia General Plan Update EIR for conversion into urban development. Development under the General Plan will result in increases of construction and operation-related criteria pollutant impacts, which are considered significant and unavoidable. General Plan policies identified under Impacts 3.3-1 and 3.3-2 serve as the mitigation which assists in reducing the severity of the impact to the extent possible while still achieving the General Plan's goals of accommodating a certain amount of growth to occur within the Planning Area.

The project is required to adhere to requirements administered by the SJVAPCD to reduce emissions to a level of compliance consistent with the District's grading regulations. Compliance with the SJVAPCD's rules and regulations will reduce potential impacts associated with air quality standard violations to a less than significant level.

In addition, development of the project will be subject to the SJVAPCD Indirect Source Review (Rule 9510) procedures that became effective on March 1, 2006. The Applicant will be required to obtain permits demonstrating compliance with Rule 9510, or payment of mitigation fees to the SJVAPCD.

- c. Tulare County is designated non-attainment for certain federal ozone and state ozone levels. The project will result in a net increase of criteria pollutants. This site was evaluated in the Visalia General Plan Update EIR for conversion into urban development. Development under the General Plan will result in increases of construction and operation-related criteria pollutant impacts, which are considered significant and unavoidable. General Plan policies identified under Impacts 3.3-1, 3.3-2, and 3.3-3 serve as the mitigation, which assists in reducing the severity of the impact to the extent possible while still achieving the General Plan's

goals of accommodating a certain amount of growth to occur within the Planning Area.

The project is required to adhere to requirements administered by the SJVAPCD to reduce emissions to a level of compliance consistent with the District's grading regulations. Compliance with the SJVAPCD's rules and regulations will reduce potential impacts associated with air quality standard violations to a less than significant level.

In addition, development of the project will be subject to the SJVAPCD Indirect Source Review (Rule 9510) procedures that became effective on March 1, 2006. The Applicant will be required to obtain permits demonstrating compliance with Rule 9510, or payment of mitigation fees to the SJVAPCD.

- d. Residences located near the proposed project may be intermittently exposed to pollutant concentrations due to construction activities. The use of construction equipment will be temporary and is subject to SJVAPCD rules and regulations. The impact is considered as less than significant.
- e. The proposed project will not involve the generation of objectionable odors that would affect a substantial number of people.

III. BIOLOGICAL RESOURCES

- a. City-wide biological resources were evaluated in the Visalia General Plan Update Environmental Impact Report (EIR) for conversion to urban use. In addition, staff had conducted an on-site visit to the site in December 2016 to observe biological conditions and did not observe any evidence or symptoms that would suggest the presence of a sensitive, candidate, or special species.

Based on the above, the site has no known species identified as a candidate, sensitive, or special status species in local or regional plans, policies, or regulations, or by the California Department of Fish and Game or U.S. Fish and Wildlife Service. The project would therefore not have a substantial adverse effect on a sensitive, candidate, or special species.

- b. There are no riparian habitats in the project area. Packwood Creek is a confined waterway that is denuded of any vegetation and dredged regularly thus eliminating the potential to foster riparian habitat. Further, the project is separated from the top of bank by over 100 feet, and it will not drain into Packwood Creek.
- c. There are no jurisdictional waterways on the project site.
- d. This development would not act as a barrier to animal movement. This site was evaluated in the Visalia General Plan Update EIR for conversion to

urban use.

- e. The City has a municipal ordinance in place to protect valley oak trees. All existing valley oak trees on the project will be under the jurisdiction of this ordinance. Any oak trees to be removed from the site are subject to the jurisdiction of the municipal ordinance.
- f. There are no local or regional habitat conservation plans for the area.

IV. CULTURAL RESOURCES

- a. There are no known historical resources located within the project area. If some potentially historical or cultural resource is unearthed during development all work should cease until a qualified professional archaeologist can evaluate the finding and make necessary mitigation recommendations.
- b. There are no known archaeological resources located within the project area. If some archaeological resource is unearthed during development all work should cease until a qualified professional archaeologist can evaluate the finding and make necessary mitigation recommendations.
- c. There are no known unique paleontological resources or geologic features located within the project area. In the event that potentially significant cultural resources are discovered during ground disturbing activities associated with project preparation, construction, or completion, work shall halt in that area until a qualified Native American Tribal observer, archeologist, or paleontologist can assess the significance of the find, and , if necessary, develop appropriate treatment measures in consultation with Tulare County Museum, Coroner, and other appropriate agencies and interested parties.
- d. There are no known human remains buried in the project vicinity. If human remains are unearthed during development all work should cease until the proper authorities are notified and a qualified professional archaeologist can evaluate the finding and make any necessary mitigation recommendations. In the event that potentially significant cultural resources are discovered during ground disturbing activities associated with project preparation, construction, or completion, work shall halt in that area until a qualified Native American Tribal observer, archeologist, or paleontologist can assess the significance of the find, and, if necessary, develop appropriate treatment measures in consultation with Tulare County Museum, Coroner, and other appropriate agencies and interested parties.

V. GEOLOGY AND SOILS

- a. The State Geologist has not issued an Alquist-Priolo Earthquake Fault Map for Tulare County. The project area is not located on or near any known earthquake fault lines. Therefore, the project will not expose people or structures to potential substantial adverse impacts involving earthquakes.

- b. The development of this site will require movement of topsoil. Existing City Engineering Division standards require that a grading and drainage plan be submitted for review to the City to ensure that off- and on-site improvements will be designed to meet City standards.
- c. The project area is relatively flat and the underlying soil is not known to be unstable. Soils in the Visalia area have few limitations with regard to development. Due to low clay content and limited topographic relief, soils in the Visalia area have low expansion characteristics.
- d. Due to low clay content, soils in the Visalia area have an expansion index of 0-20, which is defined as very low potential expansion.
- e. The project does not involve the use of septic tanks or alternative wastewater disposal systems since sanitary sewer lines are used for the disposal of wastewater at this location.

VI. GREENHOUSE GAS EMISSIONS

- a. The project is expected to generate Greenhouse Gas (GHG) emissions in the short-term as a result of the construction of residences and long-term as a result of day-to-day operation of the proposed residences.

The City has prepared and adopted a Climate Action Plan (CAP), which includes a baseline GHG emissions inventories, reduction measures, and reduction targets consistent with local and State goals. The CAP was prepared concurrently with the proposed General Plan and its impacts are also evaluated in the Visalia General Plan Update EIR.

The Visalia General Plan and the CAP both include policies intended to reduce the level of GHG emissions emitted in association with buildout conditions under the General Plan. Although emissions will be generated as a result of the project, implementation of the General Plan and CAP policies will result in fewer emissions than would be associated with a continuation of baseline conditions. Thus, the impact to GHG emissions will be less than significant.

- b. The State of California has enacted the Global Warming Solutions Act of 2006 (AB 32), which included provisions for reducing the GHG emission levels to 1990 "baseline" levels by 2020.

The proposed project will not impede the State's ability to meet the GHG emission reduction targets under AB 32. Current and probable future state and local GHG reduction measures will continue to reduce the project's contribution to climate change. As a result, the project will not contribute significantly, either individually or cumulatively, to GHG emissions.

VII. HAZARDS AND HAZARDOUS MATERIALS

- a. No hazardous materials are anticipated with the project.
- b. Construction activities associated with development of the project may include maintenance of on-site construction equipment, which could lead to minor fuel and oil spills. The use and handling of any hazardous materials during construction activities would occur in accordance with applicable federal, state, regional, and local laws. Therefore, impacts are considered to be less than significant.
- c. There are no schools located within one-quarter mile from the project. There is no reasonably foreseeable condition or incident involving the project that could affect existing or proposed school sites within one-quarter mile of school sites.
- d. The project area does not include any sites listed as hazardous materials sites pursuant to Government Code Section 65692.5.
- e. The project area is not located within two miles of a public airport.
- f. The project area is not within the vicinity of any private airstrip.
- g. The project will not interfere with the implementation of any adopted emergency response plan or evacuation plan.
- h. There are no wild lands within or near the project area.

VIII. HYDROLOGY AND WATER QUALITY

- a. The project will not violate any water quality standards of waste discharge requirements. The site, when developed, will meet the City's improvement standards for directing storm water runoff to existing City storm water drainage systems; consistent with the City's adopted City Storm Drain Master Plan.
- b. The project will not substantially deplete groundwater supplies in the project vicinity. The project will be served by a water lateral for domestic, irrigation, and fire protection use. California Water Service issued a Will Serve Letter, dated December 12, 2016, stating that water is available to serve the project. The determination of water availability shall remain voided for two years from the date of their letter. The letter also states that if the project does not commence within the two-year time frame, Cal Water will be under no obligation to serve the project unless the developer receives an updated letter from Cal Water reconfirming water availability. In addition, the letter can be rescinded at any time in the event that water supply is severely reduced by legislative, regulatory or environmental factors.

- c. The project will not result in substantial erosion on- or off-site.
- d. The project will not substantially alter the existing drainage pattern of the site or area, alter the course of a stream or river, or substantially increase the rate or amount of surface runoff in a manner which would result in flooding on- or off-site.
- e. The project will not create or contribute runoff water, which would exceed the capacity of existing or planned storm water drainage systems or provide substantial additional sources of polluted runoff.
- f. There are no reasonably foreseeable reasons why the project would result in the degradation of water quality.
- g. The project area is located within Zone X500, which indicates that the project site is not in a flood zone area with a high likelihood of flooding.
- h. The project area is located within Zone X500, which indicates that the project site is not in a flood zone area with a high likelihood of flooding.
- i. The project would not expose people or structures to risks from failure of levee or dam. The project is located downstream from the Terminus Dam; in the case of dam failure, there will be 4 hours of warning to evacuate the site.
- j. Seiche and tsunami impacts do not occur in the Visalia area. The site is relatively flat, which will contribute to the lack of impacts by mudflow occurrence.

IX. LAND USE AND PLANNING

- a. The project will not physically divide an established community. The General Plan Land Use Diagram, adopted October 14, 2014, designates the site as Low Density Residential. The project includes a request to annex the site that is currently in unincorporated Tulare County. The project will be consistent with General Plan Land Use policies that encourage concentric growth, avoiding pre-mature conversion of farmland and maintaining the viability of existing farmland by avoiding potential conflicts between agricultural production and urban uses.
- b. The project will not physically divide an established community. The General Plan Land Use Diagram, adopted October 14, 2014, designates the entire project area as Residential. There are no uses in the area that will directly conflict with the proposed residential development of the project area.

The Visalia General Plan contains multiple polices, identified under Impact 3.1-2 of the EIR, that together work to reduce the potential for impacts to the development of land as designated by the General Plan. With implementation of these policies and the existing City standards, impacts to land use development consistent with the General Plan will

be less than significant.

- c. The project does not conflict with any applicable habitat conservation plan or natural community conservation plan as it is located on a vacant dirt lot with no significant natural habitat present.

X. MINERAL RESOURCES

- a. No mineral areas of regional or statewide importance exist within the Visalia area.
- b. There are no mineral resource recovery sites delineated in the Visalia area.

XI. NOISE

- a. The project will result in noise generation typical of urban development, but not in excess of standards established in the City of Visalia's General Plan or Noise Ordinance. Noise levels will increase temporarily during the construction of these facilities but shall remain within the noise limits and restricted to the allowed hours of construction defined by the City of Visalia Noise Ordinance. Temporary increase in ambient noise levels is considered to be less than significant.

Furthermore, the Visalia General Plan contains multiple policies, identified under Impact N-P-3 through N-P-5, that work to reduce the potential for noise impacts to sensitive land uses. With implementation of Noise Impact Policies and existing City Standards, noise impacts to new noise sensitive lands uses would be less than significant.

- b. Ground-borne vibration or ground-borne noise levels may occur as part of construction activities associated with the project. Construction activities will be temporary and will not expose persons to such vibration or noise levels for an extended period of time; thus the impacts will be less than significant. There are no existing uses near the project area that create ground-borne vibration or ground-borne noise levels.
- c. Ambient noise levels will increase beyond current levels as a result of the project, however these levels will be typical of noise levels associated with urban development and not in excess of standards established in the City of Visalia's General Plan or Noise Ordinance. Noise associated with the establishment of new urban uses was previously evaluated with the General Plan for the conversion of land to urban uses.

Furthermore, the Visalia General Plan contains multiple policies, identified under Impact N-P-3 through N-P-5, that work to reduce the potential for noise impacts to sensitive land uses. With implementation of Noise Impact Policies and existing City Standards, noise impacts to new noise sensitive lands uses would be less than significant.

- d. Noise levels will increase during the construction of the project but shall remain within the limits defined by the City of Visalia Noise Ordinance. Temporary increase in ambient noise levels is considered to be less than significant.
- e. The project area is not within two miles of a public airport. The project will not expose people residing or working in the project area to excessive noise levels.
- f. There is no private airstrip near the project area.

XII. POPULATION AND HOUSING

- a. The project will not directly induce substantial population growth that is in excess of that planned in the General Plan.
- b. Development of the site will not displace any housing on the site.
- c. Development of the site will not displace any people on the site.

XIII. PUBLIC SERVICES

- a.
 - i. Fire protection facilities are located at the Visalia Station 56 and can adequately serve the site without a need for alteration. Impact fees will be paid to mitigate the project's proportionate impact on these facilities.
 - ii. Current police protection facilities can adequately serve the site without a need for alteration. Impact fees will be paid to mitigate the project's proportionate impact on these facilities.
 - iii. The project will generate new students for which existing schools in the area may accommodate. In addition, to address direct impacts, the project will be required to pay residential impact fees. These fees are considered to be conclusive mitigation for direct impacts. The project includes residential units that will create a need for park facilities.
 - iv. Other public facilities can adequately serve the site without a need for alteration.

XIV. RECREATION

- a. The proposed project does not include recreational facilities or require the construction or expansion of recreational facilities within the area that might have an adverse physical effect on the environment.
- b. The proposed project does not include recreational facilities or require the construction or expansion of recreational facilities within the area that might have an adverse physical effect on the environment.

XV. TRANSPORTATION AND TRAFFIC

- a. Development and operation of the project is not anticipated to conflict with applicable plans,

ordinances, or policies establishing measures of effectiveness of the City's circulation system. The project will result in an increase in traffic levels on arterial and collector roadways, although the City of Visalia's Circulation Element has been prepared to address this increase in traffic.

- b. Development of the site will result in increased traffic in the area, but will not cause a substantial increase in traffic on the city's existing circulation pattern. This site was evaluated in the Visalia General Plan Update Environmental Impact Report (EIR) for urban use.
- c. The project will not result in nor require a need to change air traffic patterns.
- d. There are no planned designs that are considered hazardous.
- e. The project will not result in inadequate emergency access.
- f. The project will not conflict with adopted policies, plans, or programs regarding public transit, bicycle, or pedestrian facilities, or otherwise decrease the performance or safety of such facilities.

XVI. UTILITIES AND SERVICE SYSTEMS

- a. Future development of the site will connect and/or extended City sanitary sewer lines, consistent with the City Sewer Master Plan.
- b. The project will not result in the construction of new water or wastewater treatment facilities or expansion of existing facilities, the construction of which could cause significant environmental effects.
- c. There are currently stubbed storm drain lines in Akers and Riggin. The project, when developed, will be required to extend these storm drain lines connecting to the existing City storm water drainage lines that handle on-site and street runoff. Usage of these lines shall be consistent with the City Storm Drain Master Plan. These improvements will not cause significant environmental impacts.
- d. California Water Service Company has determined that there are sufficient water supplies to support the site, and that service can be extended to the site. California Water Service issued a Will Serve Letter, dated February 7, 2017, stating that water is available to serve the project. The determination of water availability shall remain voided for two years from the date of their letter. The letter also states that if the project does not commence within the two-year time frame, Cal Water will be under no obligation to serve the project unless the developer receives an updated letter from Cal Water reconfirming water availability. In addition, the letter can be rescinded at any time in the event that water supply is severely reduced by legislative, regulatory

or environmental factors.

- e. The City has determined that there is adequate capacity existing to serve the site's projected wastewater treatment demands at the City wastewater treatment plant.
- f. Current solid waste disposal facilities can adequately serve the site without a need for alteration.
- g. The project will be able to meet the applicable regulations for solid waste. Removal of debris from construction will be subject to the City's waste disposal requirements.

XVIII. TRIBAL CULTURAL RESOURCES

The proposed project would not cause a substantial adverse change in the significance of a tribal cultural resource, defined in Public Resources Code section 21074 as either a site, feature, place, cultural landscape that is geographically defined in terms of the size and scope of the landscape, sacred place, or object with cultural value to a California Native American tribe, and that is:

- a. The site is not listed or eligible for listing in the California Register of Historical Resources, or in a local register of historical resources as defined in Public Resources Code section 5020.1(k), or
- b. The site has been determined to not be significant pursuant to criteria set forth in subdivision (c) of Public Resources Code Section 5024.1. In applying the criteria set forth in subdivision (c) of Public Resource Code Section 5024.1, the lead agency shall consider the significance of the resource to a California Native American tribe.

Further, the EIR (SCH 2010041078) for the 2014 General Plan update included a thorough review of sacred lands files through the California Native American Heritage Commission. The sacred lands file did not contain any known cultural resources information for the Visalia Planning Area.

Additionally, invitations for early consultation were sent to the five Tribes with a historic presence in the Visalia Planning Area. No formal response was received by any of the tribal representatives.

IXX. MANDATORY FINDINGS OF SIGNIFICANCE

- a. The project will not affect the habitat of a fish or wildlife species or a plant or animal community. This site was evaluated in the Program EIR (SCH No. 2010041078) for the City of Visalia's General Plan Update for conversion to urban use. The City adopted mitigation measures for conversion to urban development. Where effects were still determined to be significant a statement of overriding considerations was made.

- b. This site was evaluated in the Program EIR (SCH No. 2010041078) for the City of Visalia General Plan Update for the area's conversion to urban use. The City adopted mitigation measures for conversion to urban development. Where effects were still determined to be significant a statement of overriding considerations was made.
- c. This site was evaluated in the Program EIR (SCH No. 2010041078) for the City of Visalia General Plan Update for conversion to urban use. The City adopted mitigation measures for conversion to urban development. Where effects were still determined to be significant a statement of overriding considerations was made.

DETERMINATION OF REQUIRED ENVIRONMENTAL DOCUMENT

On the basis of this initial evaluation:

- I find that the proposed project **COULD NOT** have a significant effect on the environment. **A NEGATIVE DECLARATION WILL BE PREPARED.**
- I find that although the proposed project could have a significant effect on the environment, there will not be a significant effect in this case because the mitigation measures described on the attached sheet have been added to the project. **A MITIGATED NEGATIVE DECLARATION WILL BE PREPARED.**
- I find the proposed project **MAY** have a significant effect on the environment, and an **ENVIRONMENTAL IMPACT REPORT** is required.
- I find that the proposed project **MAY** have a "potentially significant impact" or "potentially significant unless mitigated" impact on the environment, but at least one effect 1) has been adequately analyzed in an earlier document pursuant to applicable legal standards, and 2) has been addressed by mitigation measures based on the earlier analysis as described on attached sheets. An **ENVIRONMENTAL IMPACT REPORT** is required, but it must analyze only the effects that remain to be addressed.
- I find that as a result of the proposed project no new effects could occur, or new mitigation measures would be required that have not been addressed within the scope of the Program Environmental Impact Report (SCH No. 2010041078). The Environmental Impact Report prepared for the City of Visalia General Plan was certified by Resolution No. 2014-37 adopted on October 14, 2014. **THE PROGRAM ENVIRONMENTAL IMPACT REPORT WILL BE UTILIZED.**

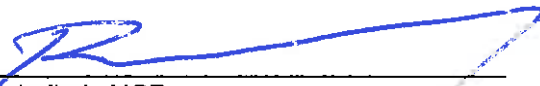

Paul Scheibel, AICP
Environmental Coordinator

March 28, 2017
Date

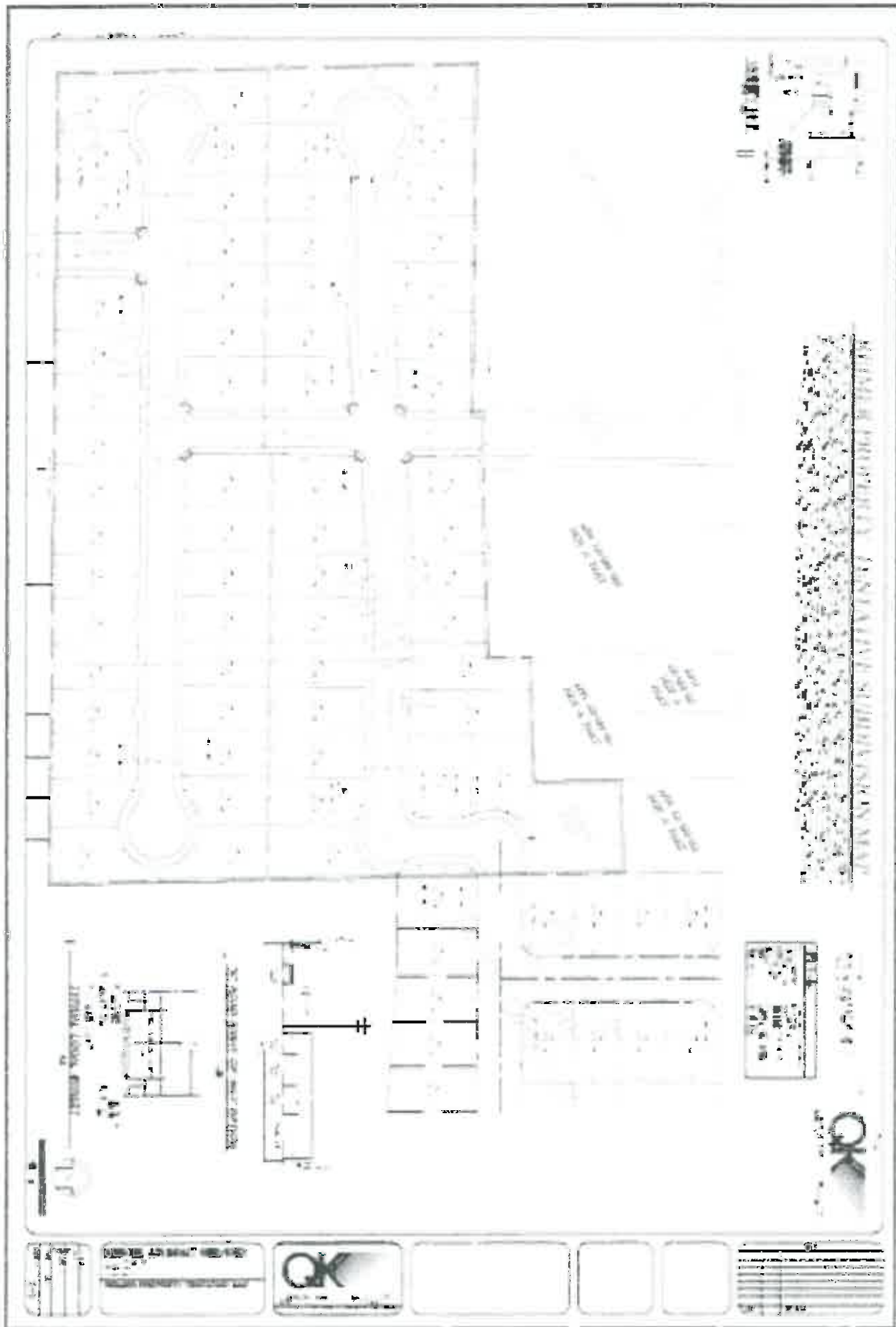

NO.	DATE

DESIGNED AND DRAWN BY: [Name]
CHECKED BY: [Name]



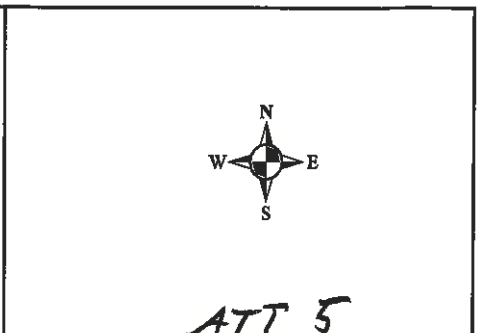
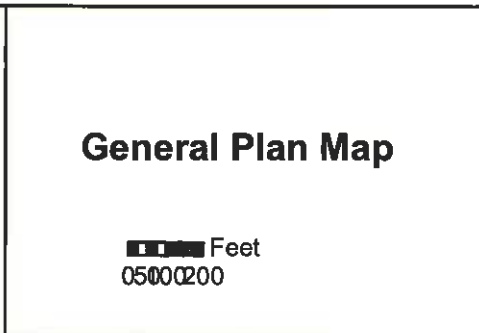
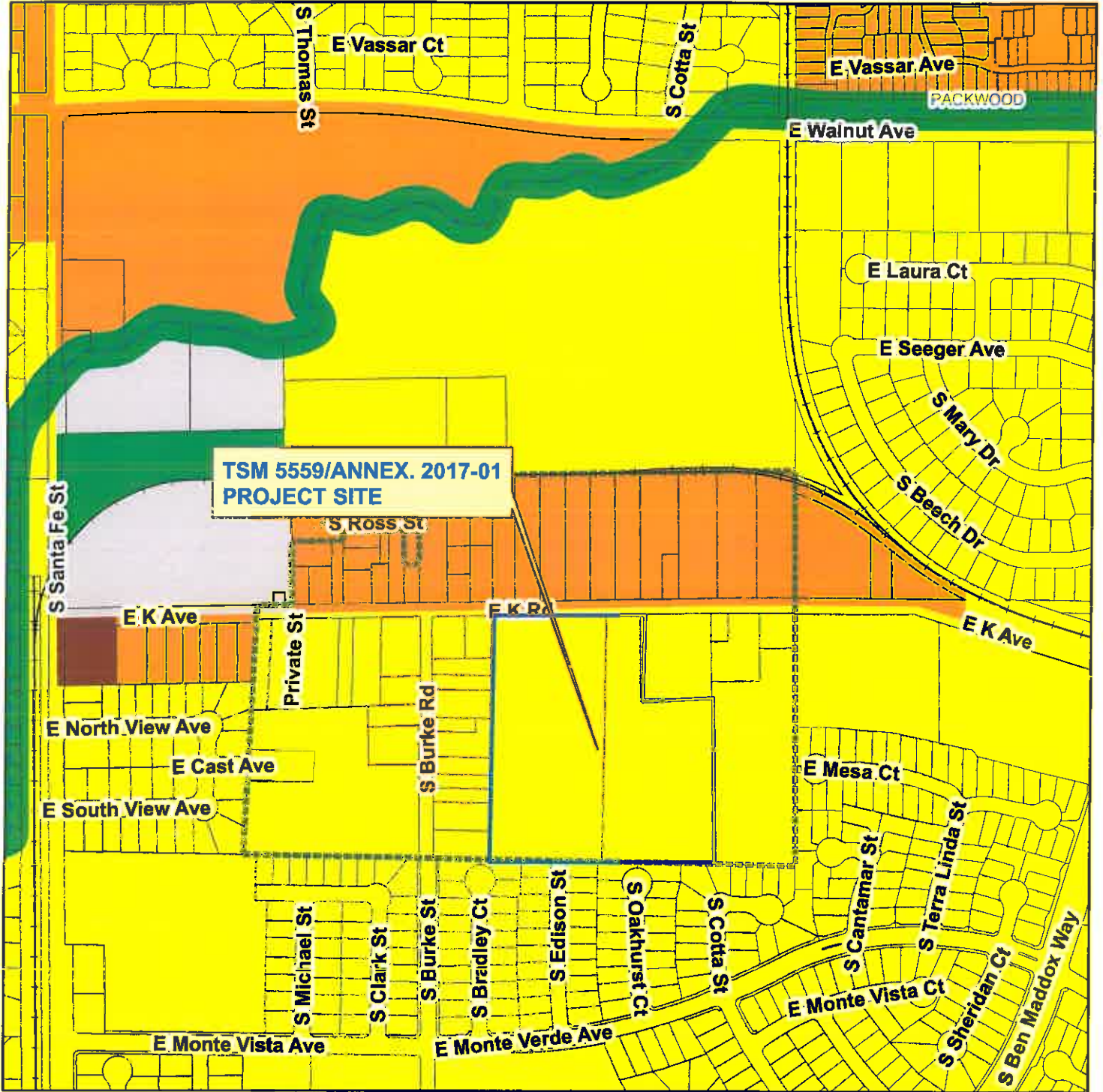

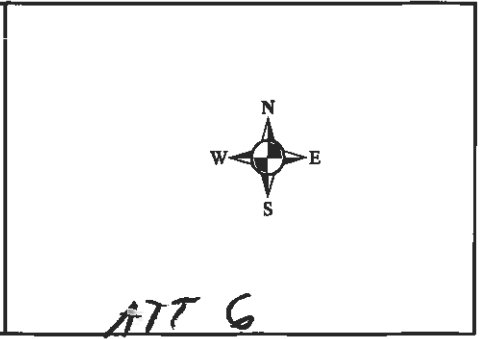
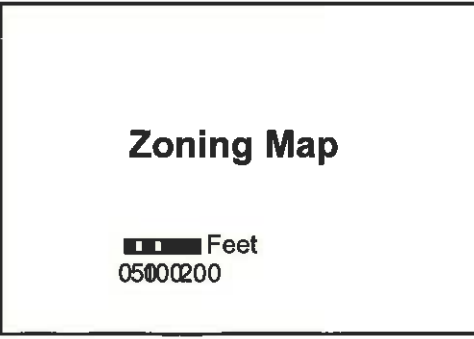
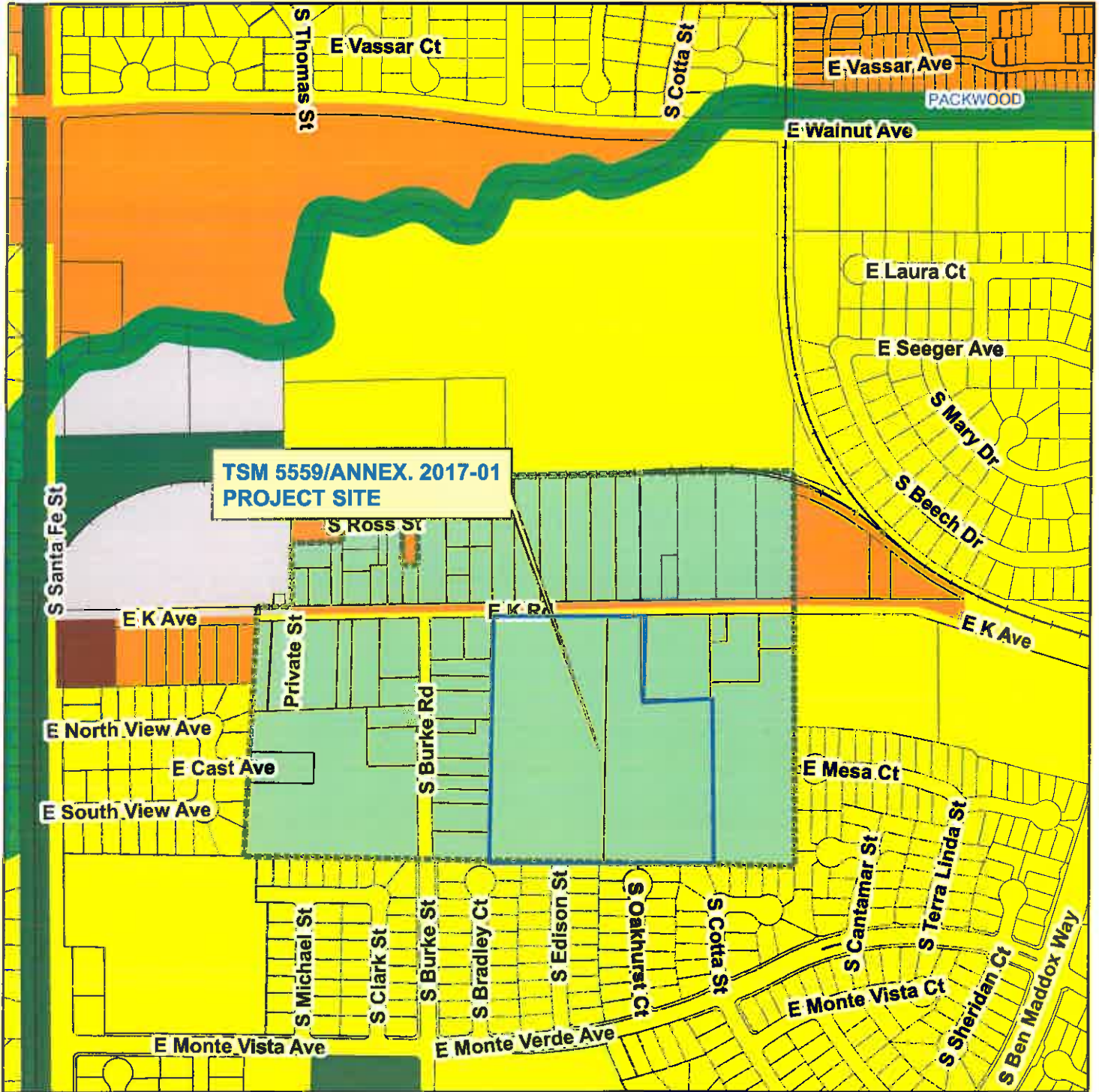

TSM 5559/ANNEX. 2017-01



Aerial Map

0 50 100 Feet
05000200

ATT 7